

SCOTSMAN

AUTOMATIC AIR AND WATER COOLED NUGGET ICE MAKER/DISPENSER

N D E 6 5 4



VOLUME PRODUCTION • 24 HOUR

Based on Air/Water Temperatures	Air-Cooled		Water-Cooled	
	70°/50° lbs./kg.	90°/70° lbs./kg.	70°/50° lbs./kg.	90°/70° lbs./kg.
NDE654	605/274	465/211	620/281	540/245

YOU'LL VALUE THE DIFFERENCE OF OUR NUGGET ICE MAKER/DISPENSERS

- Dispenses soft, chewable nugget ice that is preferred by consumers.
- Dispenses ice or water at a push of a lever, but incorporates advanced electronics, which eliminate most mechanical switches or sensors.
- Photoelectric eye bin control allows maximum storage in the bin.

WARRANTY *See your dealer for complete warranty details.*

- 2 years parts on all components.
- 2 years labor on all components.
- 5 years parts on compressor.



NUGGET ICE

Versatile, inexpensive to produce, used in carbonated beverages and salad bars.



DMS 21 STAND

26" x 21" x 36"
Stainless Steel.

This product qualifies for the following listings:



Ice Maker/Dispenser Specifications

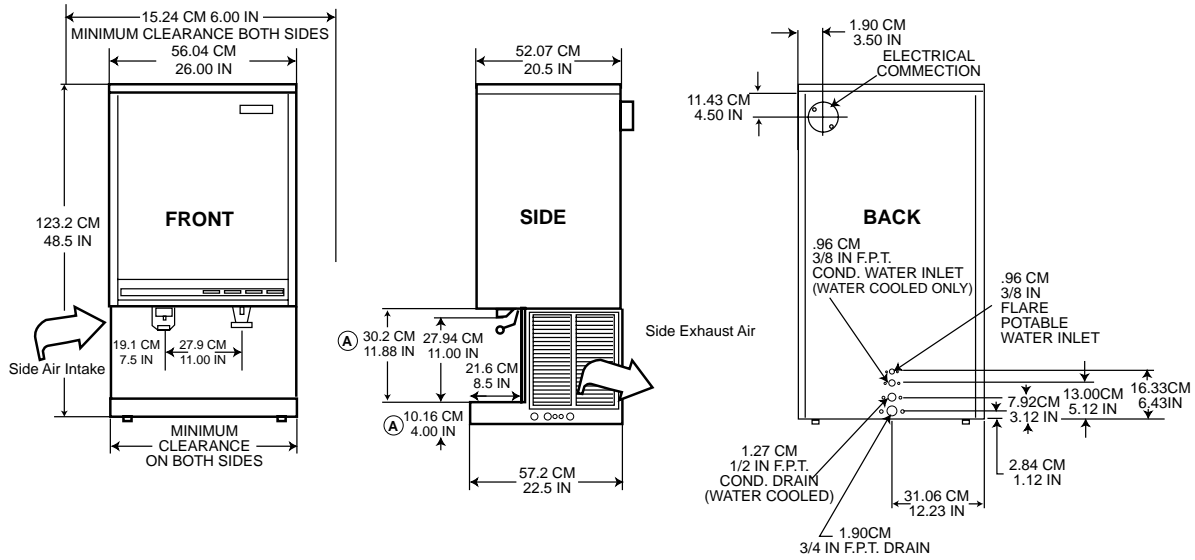

INSTALLATION NOTE: Allow 6" minimum space at sides and back for ventilation and utility connections.

All models: Dimensions: W x D x H Unit: 26" x 22 1/2" x 48 1/2" Shipping Carton: 30" x 24" x 53"

Model Number	Condenser Unit	Bin Capacity lbs./kg.	Basic Electrical Volts/Hz/Phase	Max. Fuse Size or HACR Circuit Breaker	Comp. HP	Circuit Wires	Min. Circuit Ampacity	Shipping Weight lbs./kg.	Power Consumption KWH/100 lbs. 90°/70°F	Water Usage Gallons/100 lbs. 90°/70°F	
										Potable	Condenser
NDE654AS-1A	AIR	40/18	115/60/1	25	1/2	2	19.3	285/129	5.7	12	-
NDE654WS-1A	WATER	40/18	115/60/1	20	1/2	2	17.8	285/129	4.3	12	103.4

All units with Stainless Steel finish.
Refrigerant: R-404A.

OPTIONS:
KPCG150: Portion Control Kit.
KSPI: Splash Panel Kit.
KWB3: Wall Mounting Kit.

ICE VENDING CAPACITY—PEAK VENDS PER HOUR

	Bin Cap. lbs./kg.	1-Hr. Recovery Cap.* lbs./kg.	Number of Vends per Hour From Full Bin + Recovery			
			1 oz. Vends	2 oz. Vends	3 oz. Vends	4 oz. Vends
NDE654A	40/18	25/11	560 + 400	280 + 200	185 + 130	140 + 100
NDE654W	40/18	25/11	560 + 400	280 + 200	185 + 130	140 + 100

*Based on 70° Air and 50° Water Temperatures.

Scotsman's ice machines are not designed for outdoor installations. Scotsman remote condensers are designed for outdoor installations.

Machine requires voltage indicated on rating name plate. Failures caused by improper voltage are not considered factory defects. Extended periods of operation at temperatures exceeding limitations constitutes misuse under the terms of Scotsman Manufacturer's Limited Warranty, resulting in a loss of warranty coverage. Specifications and design are subject to change without notice.

Consult Your Local SCOTSMAN Representative At:

IMPORTANT OPERATING REQUIREMENTS:

	Minimum	Maximum
Air Temperatures	50°F (10°C)	100°F (37.7°C)
Water Temperatures	40°F (4.4°C)	100°F (37.7°C)
Water Pressures	20 PSIG	120 PSIG
Electrical Voltage	-5%	+10%

YOU'LL VALUE THE DIFFERENCE™

775 Corporate Woods Parkway • Vernon Hills, IL 60061 • 1-800-SCOTSMAN • (847) 913-9844
Visit our website at: www.scotsman-ice.com • E-mail: customer.service@scotsman-ice.com