

# HID312, HID525 and HID540 Service Parts

This is the illustrated parts list for Scotsman ice maker-dispenser models HID312, HID525 and HID540.

They were manufactured in 2 voltages and there is also a separate wall mount model. Please confirm the complete model number before ordering a part.

Complete models are:

HID312A-1A, air cooled 115 volt

HID312AW-1A, air cooled, wall mount, 115 volt

HID312A-6A, air cooled, 50 Hz

HID525A-1A, air cooled, 115 volt

HID525AW-1A, air cooled, wall mount, 115 volt

HID525W-1A, water cooled, 115 volt

HID540A-1A, air cooled, 115 volt

HID540AW-1A, air cooled, wall mount, 115 volt

HID540W-1A, water cooled, 115 volt

## Contents

HID312 Cabinet.....	2
HID525 Cabinet.....	3
HID540 Cabinet.....	4
HID312 Refrigeration - R-134a.....	5
HID525 and HID540 Refrigeration - R-404A .....	6
HID 312 Dispensing Components .....	7
HID525 and HID540 Dispensing Components.....	8
Drain Area.....	9
Water Valves, Tubing, Support Panels .....	10
Ice Chute, Sweep and Motor Sensor.....	11
Ice Making Components.....	12
Electrical.....	13
Accessories .....	14
HID325 and HID540 Wiring Diagram .....	15
HID525 and HID540 Schematic Diagram.....	16
HID312 Wiring Diagram.....	17
HID312 Schematic Diagram.....	18

# HID312, HID525 and HID540 Service Parts

## HID312 Cabinet

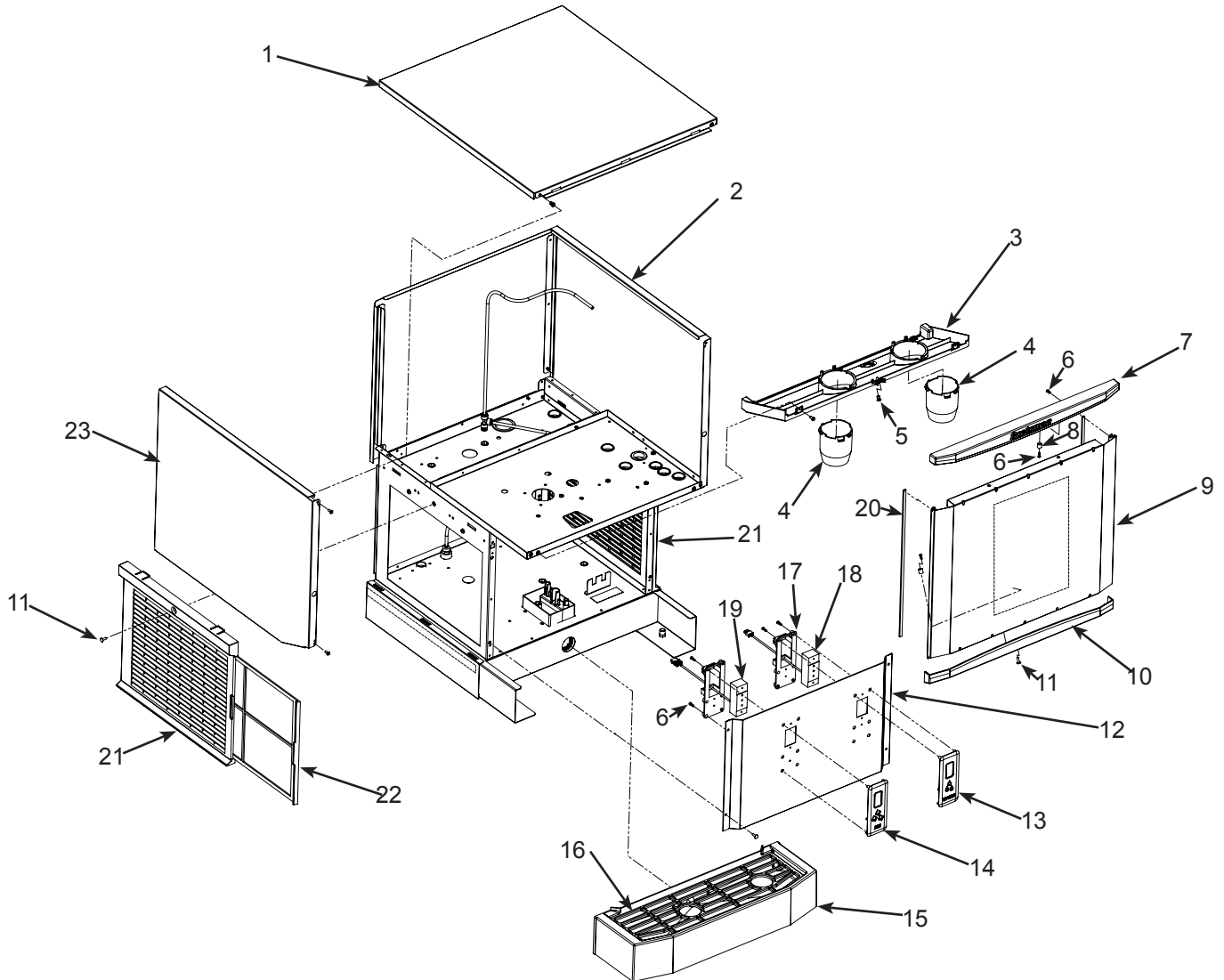

Item Number	Part Number	Description
1	A40225-021	Top panel
2	A40213-002	Right side panel
3	02-4800-21	Holder, disp chutes
4	02-4788-01	Ice or Water chute
5	03-1642-08	Insert
6	03-3836-02	Screw
7	02-4798-01	Top trim strip
8	02-4824-01	Spacer
9	A40219-021	Front panel, incl items 7, 10
10	02-4798-02	Lower trim strip
11	03-3813-02	Screw
12	A40220-001	Splash panel
	A40266-001	Splash panel, wall mount only
13	02-4825-12	Cover, water sensor
14	02-4825-11	Cover, ice sensor
15	A40298-001	Drip tray, for 312
16	02-4778-01	Grill/cup rest, for 312
17	02-4825-03	Sensor holder
18	11-0614-02	Water disp sensor
19	11-0614-01	Ice disp sensor
20	19-0503-01	Gasket, 3 units per side
21	02-4763-01	Louvered panel
22	02-4762-01	Air filter
23	A40213-001	Left side panel

Wall Mount Bracket. Will NOT convert non wall mount models to wall mount.  
A40379-016

# HID312, HID525 and HID540 Service Parts

## HID525 Cabinet

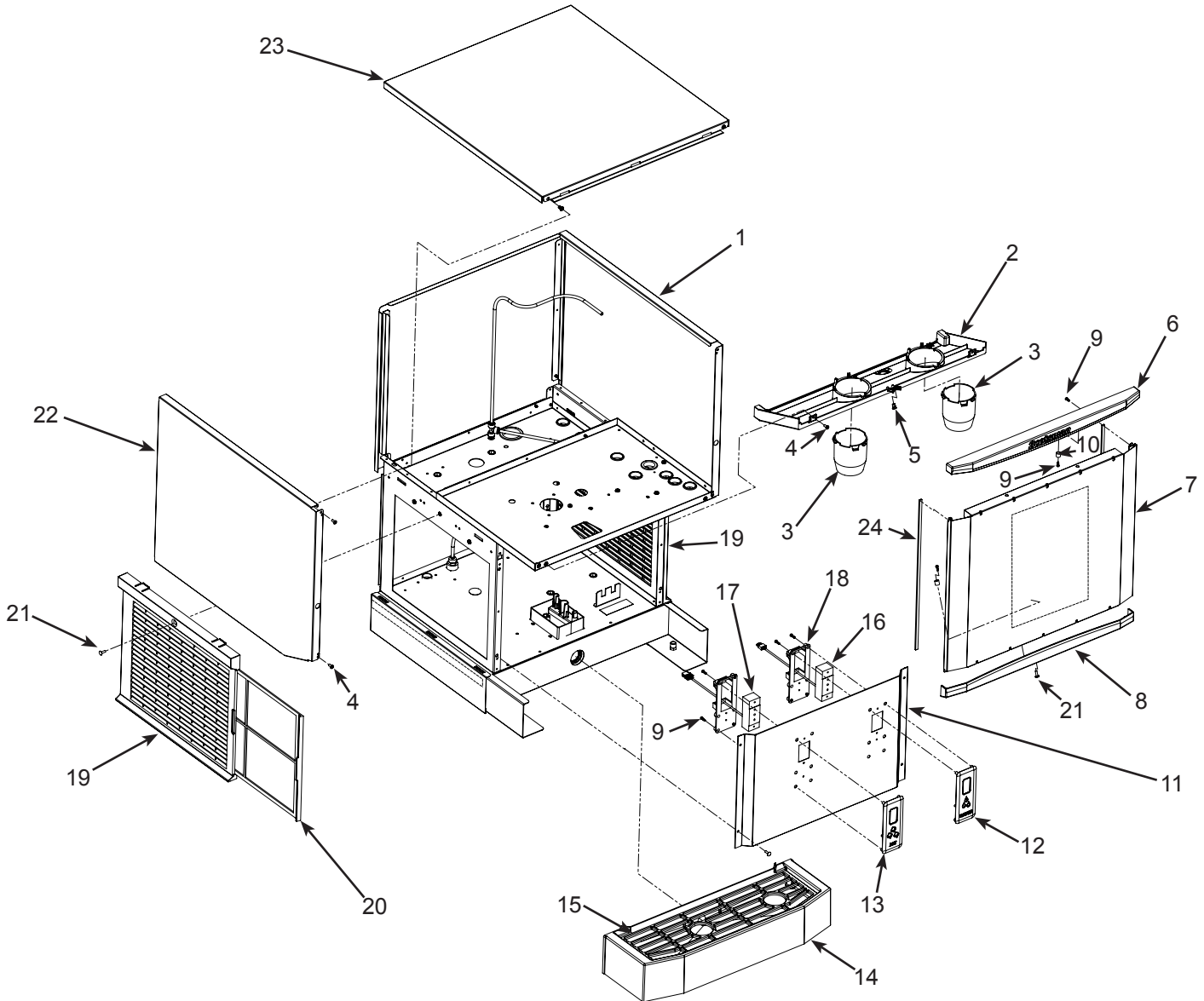

Item Number	Part Number	Description
1	A40213-002	Right side panel
2	02-4801-21	Chute holder
3	02-4788-01	Dispense chute, water or ice
4	03-1403-17	Screw
5	03-1642-08	Insert
6	02-4799-01	Top trim strip
7	A40219-022	Front panel, includes item 6, 8
8	02-4799-02	Bottom trim strip
9	03-3836-02	Screw
10	02-4824-01	Spacer
11	A40220-002	Splash panel
	A40266-002	Splash panel, wall mount only
12	02-4825-12	Cover, water sensor
13	02-4825-11	Cover, ice sensor
14	A40298-002	Drip tray
15	02-4779-01	Grill/cup rest
16	11-0614-02	Water disp sensor
17	11-0614-01	Ice disp sensor
18	02-4825-03	Sensor holder
19	02-4763-01	Louvered panel
20	02-4762-01	Air filter
21	03-3813-02	Screw
22	A40213-001	Left side panel
23	A40225-022	Top panel
24	19-0503-01	Gasket, 3 units per side

Wall Mount Bracket. Will NOT convert non wall mount models to wall mount.  
A40379-021

# HID312, HID525 and HID540 Service Parts

## HID540 Cabinet

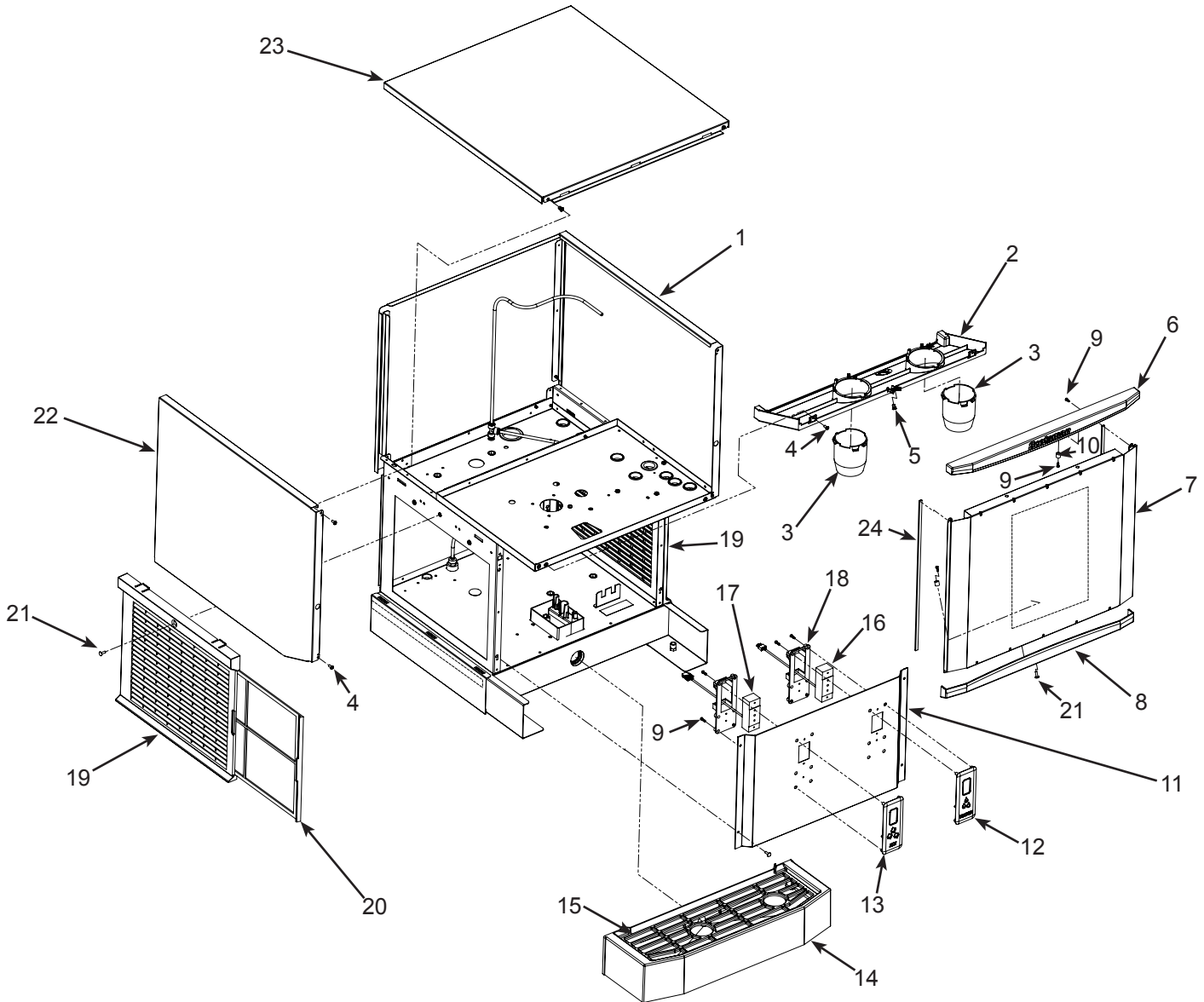

Item Number	Part Number	Description
1	A40214-002	Right side panel
2	02-4801-21	Chute holder
3	02-4788-01	Dispense chute, water or ice
4	03-1403-17	Screw
5	03-1642-08	Insert
6	02-4799-01	Top trim strip
7	A40219-023	Front panel, includes item 6, 8
8	02-4799-02	Bottom trim strip
9	03-3836-02	Screw
10	02-4824-01	Spacer
11	A40220-002	Splash panel
	A40266-002	Splash panel, wall mount only
12	02-4825-12	Cover, water sensor
13	02-4825-11	Cover, ice sensor
14	A40298-002	Drip tray
15	02-4779-01	Grill/cup rest
16	11-0614-02	Water disp sensor
17	11-0614-01	Ice disp sensor
18	02-4825-03	Sensor holder
19	02-4763-01	Louvered panel
20	02-4762-01	Air filter
21	03-3813-02	Screw
22	A40214-001	Left side panel
23	A40225-022	Top panel
24	19-0503-01	Gasket, 3 units per side

Wall Mount Bracket. Will NOT convert non wall mount models to wall mount.  
A40379-021

# HID312, HID525 and HID540 Service Parts

## HID312 Refrigeration - R-134a

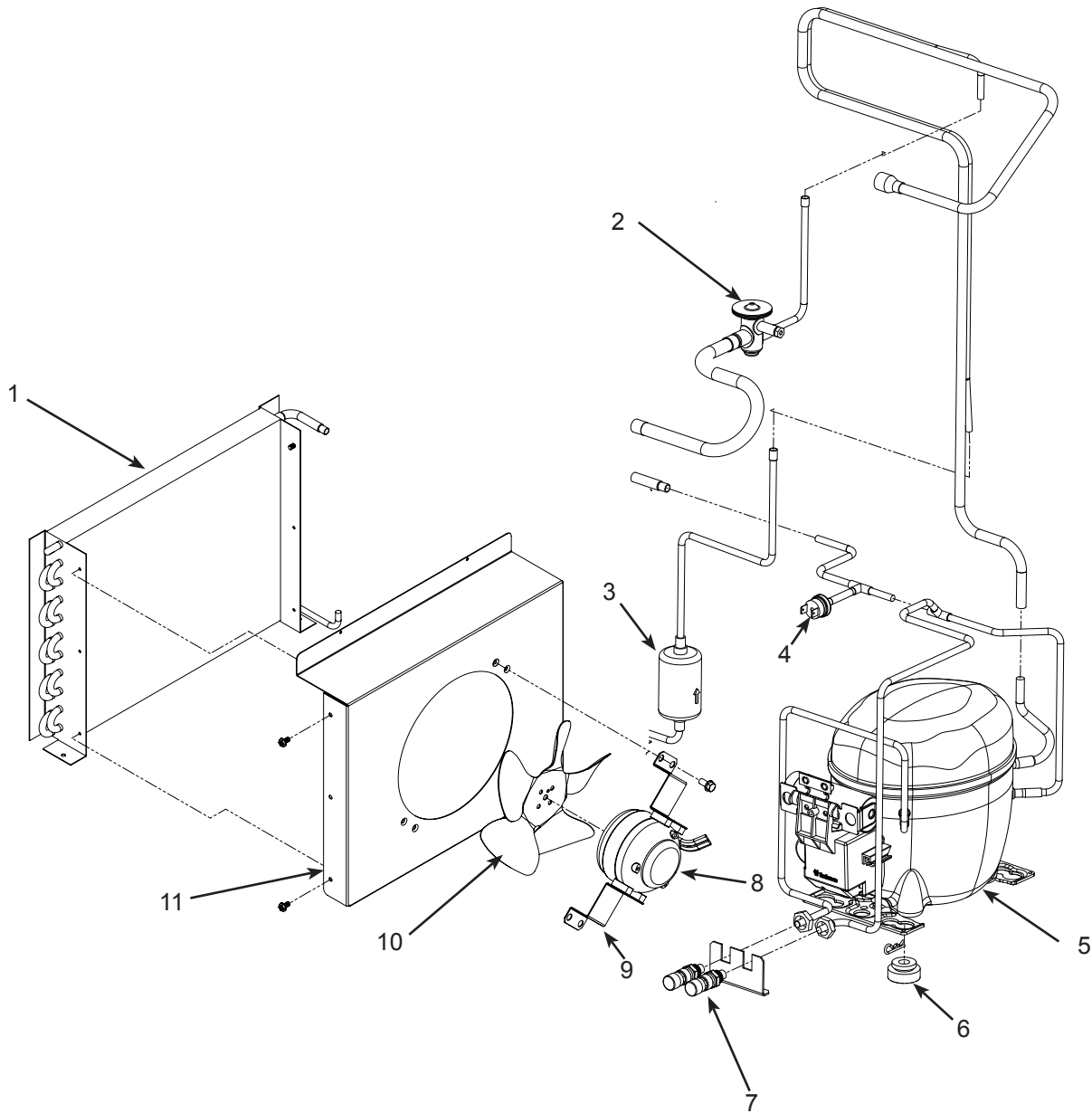

Item Number	Part Number	Description
1	18-8966-01	Condenser
2	16-1214-01	TXV
3	02-3319-01	Dryer
4	11-0501-04	High pressure cut out
5	18-8957-21	Compressor, 115 volt
	18-8957-26	Compressor, 50 Hz
	18-8957-51	Start relay, 115 volt
	18-8957-61	Start relay, 50 Hz
	18-8957-52	Start capacitor, 115 volt
	18-8957-62	Start capacitor, 50 Hz
	18-8957-53	Overload, 115 volt
	18-8957-63	Overload, 50 Hz

6	18-8964-01	Grommets
	03-1407-08	Sleeve
7	16-1138-01	Valve body
	16-1139-01	Valve core
	16-1140-01	Valve cap
8	12-2989-01	Fan motor, 115 volt
	12-2989-02	Fan motor, 50 Hz
9	A40323-001	Motor bracket
10	18-8941-01	Fan blade
11	A40322-001	Fan shroud

All compressors listed here include their starting components.



# HID312, HID525 and HID540 Service Parts

## HID 312 Dispensing Components

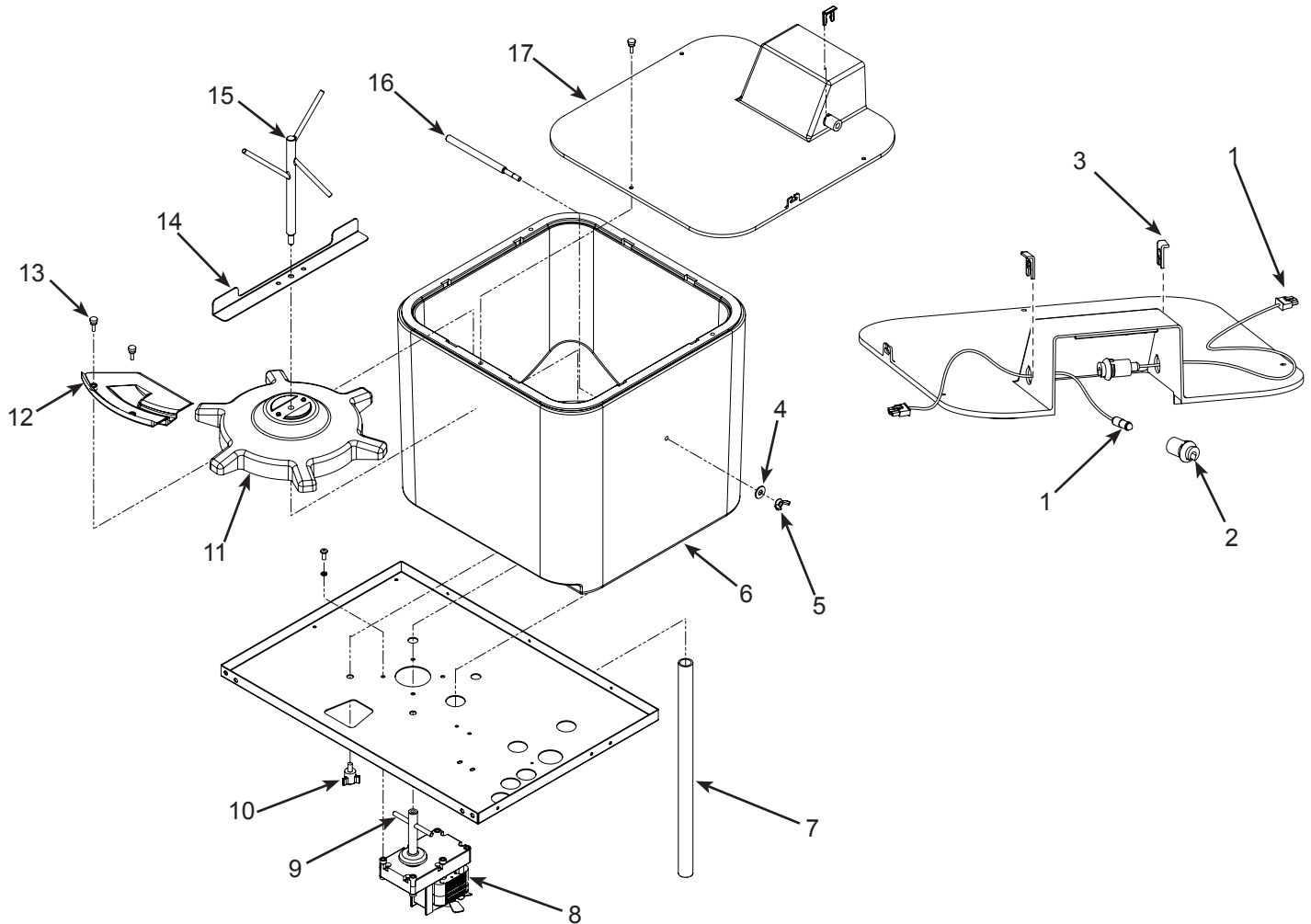

Item Number	Part Number	Description
1	12-3094-01	Photo eye sensor set
2	13-0964-01	Sensor grommet
3	02-4381-03	Clip
4	03-1407-06	Washer
5	03-0255-00	Wing nut
6	A40306-001	Storage bin, with insulation. For 312
7	02-4794-01	Drain hose, for 312
8	12-3084-01	Drive motor, 115 volt
	12-3084-02	Drive motor, 230/50 Hz
9	02-4774-01	Drive pin
10	03-1675-02	Bin fastener
11	02-4770-01	Dispense rotor, for 312
12	02-4772-01	Chute cover, for 312
13	03-0727-05	Thumb screw
14	A40229-001	Agitator bar, for 312
15	02-4789-01	Agitator
16	02-4829-01	Ice rod, for 312
17	02-4784-01	Bin cover, for 312

# HID312, HID525 and HID540 Service Parts

## HID525 and HID540 Dispensing Components

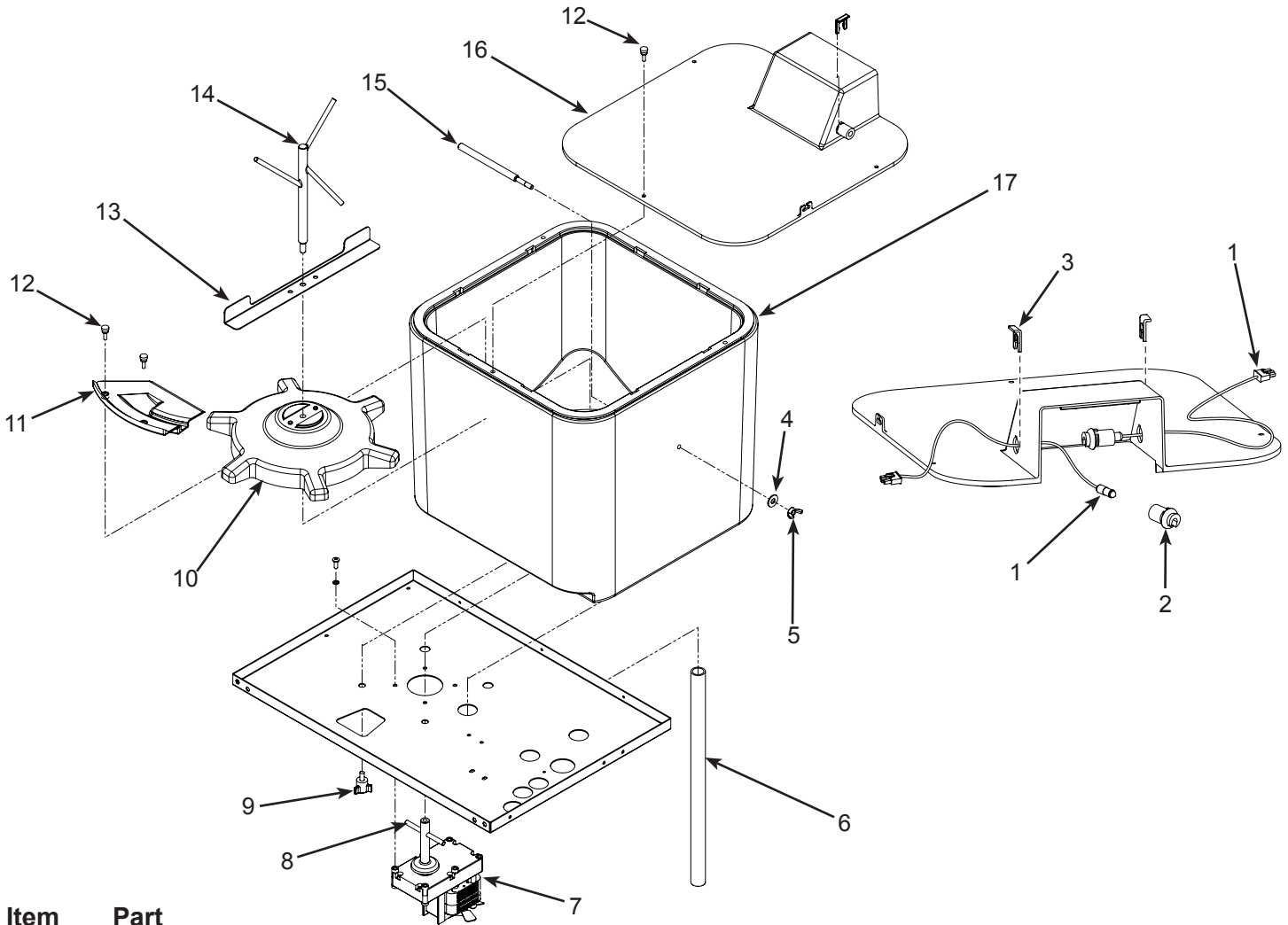

Item Number	Part Number	Description
1	12-3094-01	Photo eye sensor set
2	13-0964-01	Sensor grommet
3	02-4381-03	Clip
4	03-1407-06	Washer
5	03-0255-00	Wing nut
6	02-4833-01	Drain hose, for 525 or 540
7	12-3084-01	Drive motor, 115 volt
	12-3084-02	Drive motor, 230/50 Hz
8	02-4774-01	Drive pin
9	03-1675-02	Bin fastener
10	02-4771-01	Dispense rotor, for 525 or 540
11	02-4773-01	Chute cover, for 525 or 540
12	03-0727-05	Thumb screw
13	A40229-002	Agitator bar, for 525 or 540
14	02-4789-01	Agitator
15	02-4829-02	Ice bar, for 525 or 540
16	02-4785-01	Storage bin cover, for 525 or 540
17	A40306-002	Storage bin with insulation for HID525
	A40306-003	Storage bin with insulation for HID540



# HID312, HID525 and HID540 Service Parts

## Drain Area

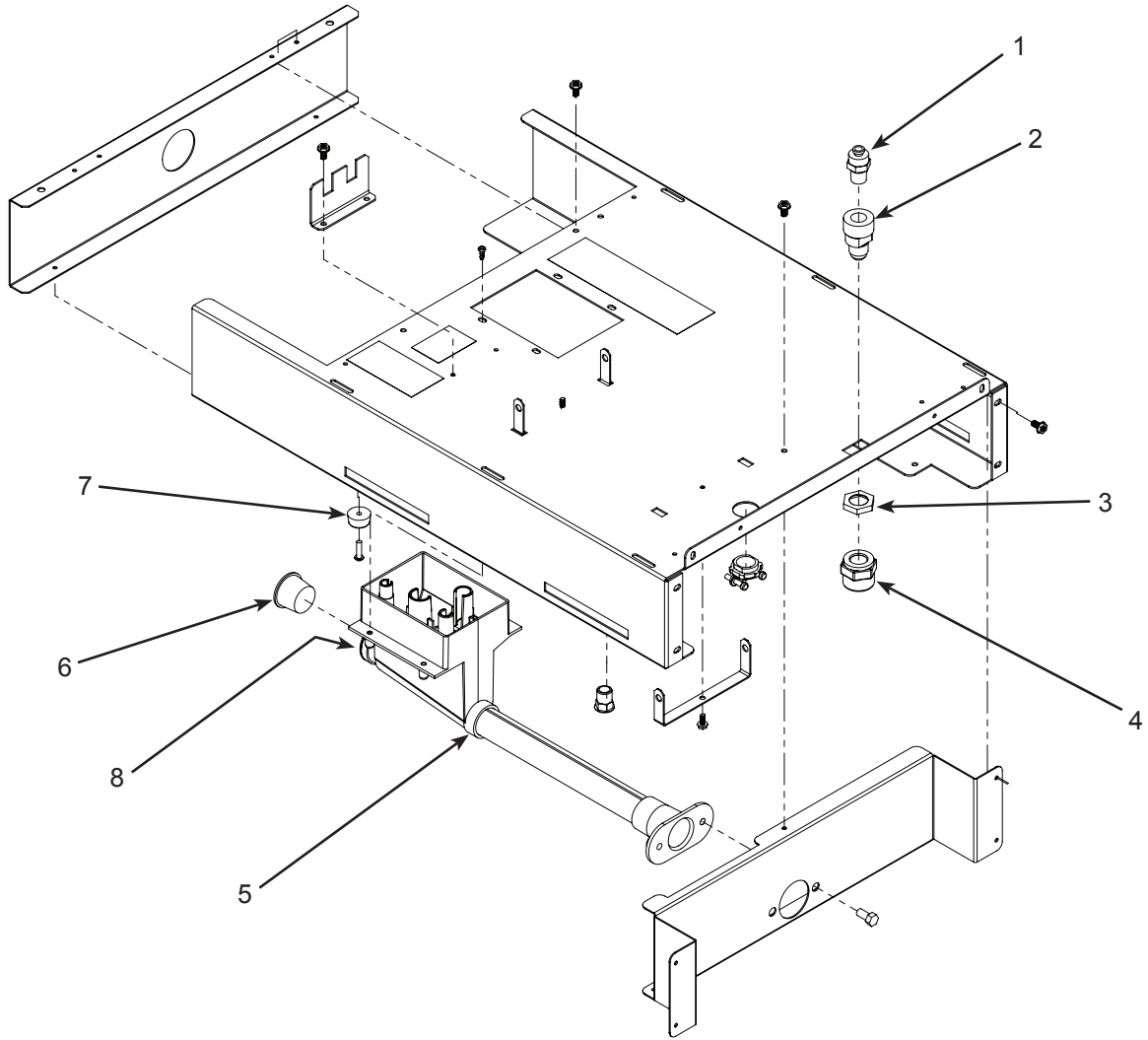

Item Number	Part Number	Description
1	16-1039-01	Male connector
2	16-0835-01	Fitting
3	03-1394-01	Pal nut
4	16-1150-01	Water inlet fitting, 50 Hz only. Provides male 3/4 gas BNF threads.
5	02-4832-01	Drain assembly
6	13-0562-10	Plug, used on wall mount models
7	03-3940-01	Plastic grommet
8	13-0617-29	O-ring

# HID312, HID525 and HID540 Service Parts

## Water Valves, Tubing, Support Panels

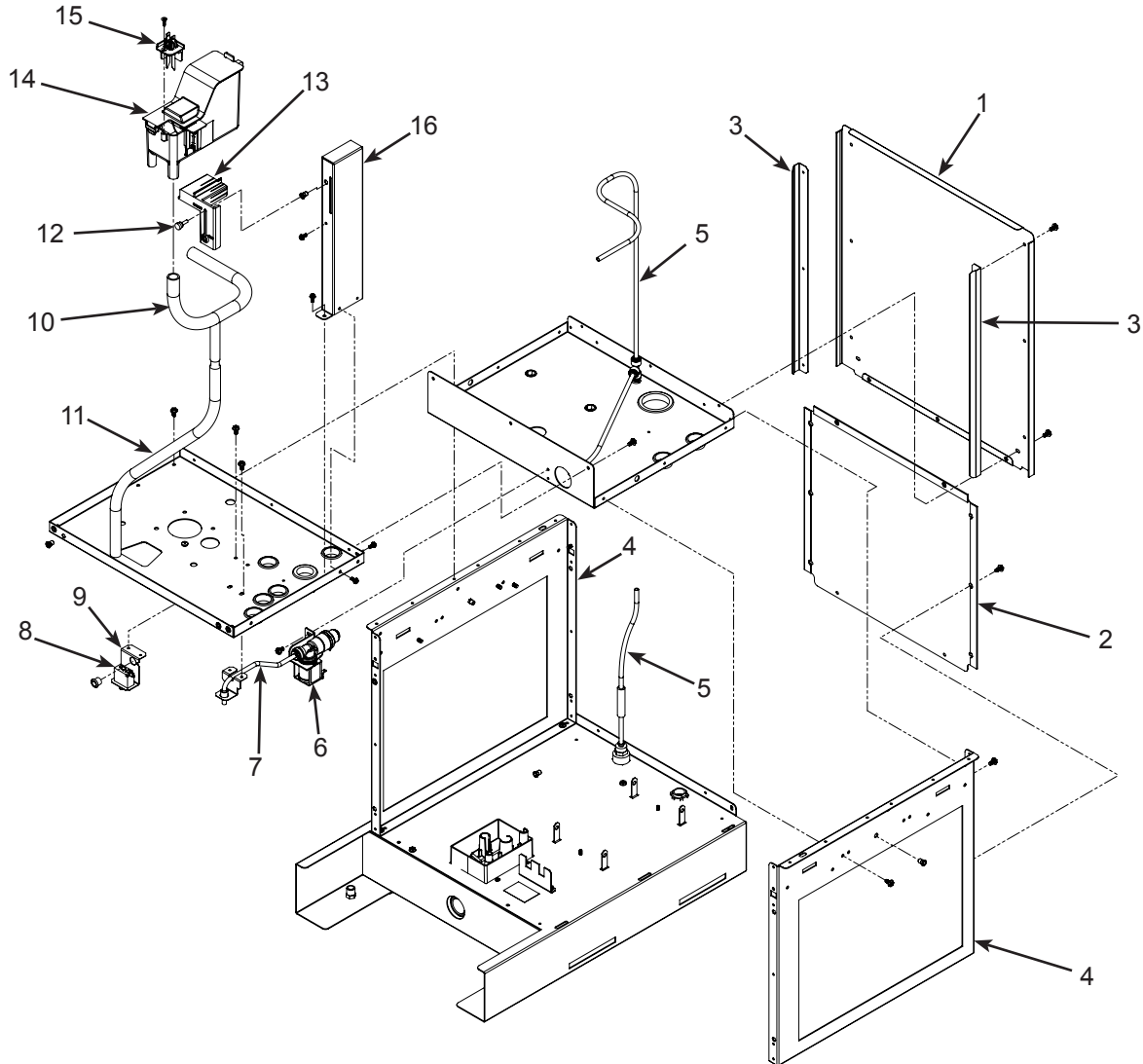

Item Number	Part Number	Description
1	A40215-001	Upper back panel, for 312
	A40216-001	Upper back panel, for 525
	A40216-002	Upper back panel, for 540
2	A40305-001	Bottom back panel, for 312
	A40305-002	Bottom back panel, for 525, 540
3	A40246-001	Panel guide, for 312 or 525
	A40246-002	Panel guide, for 540
4	A40210-001	Support frame
5	13-0895-01	Water tubing, order 5 units
6	12-3088-01	Water solenoid valve, 115 volt
	12-3088-02	Water solenoid valve, 50 Hz
7	A40257-001	Water tube, for 312
	A40257-002	Water tube, for 525 or 540
8	12-2501-01	Switch, vend disable
9	A40247-001	Bracket
10	02-4792-01	Evap water inlet, for 312
	02-4793-01	Evap water inlet, for 525, 540
11	02-4795-01	Drain tube, for 312, 525
	02-4795-02	Drain tube, for 540
12	03-0727-05	Thumb screw
13	02-4759-01	Reservoir bracket
14	A39789-001	Reservoir
14a	02-2217-02	Float valve, part of 14
15	A39790-001	Water sensor
16	A40230-001	Reservoir post, for 312, 525
	A40230-002	Reservoir post, for 540

# HID312, HID525 and HID540 Service Parts

## Ice Chute, Sweep and Motor Sensor

HID312

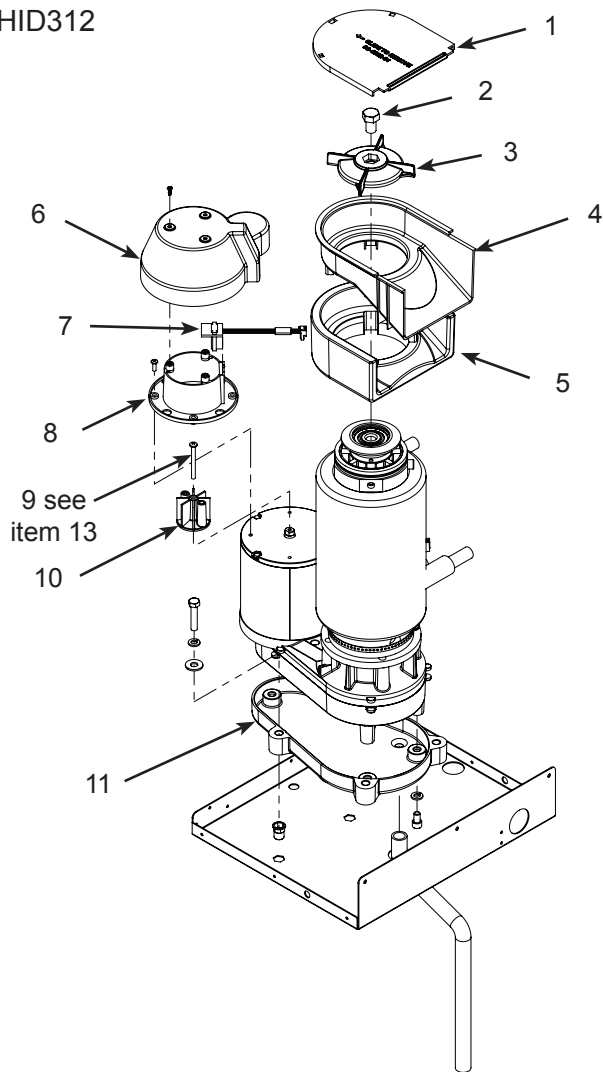

HID525  
HID540

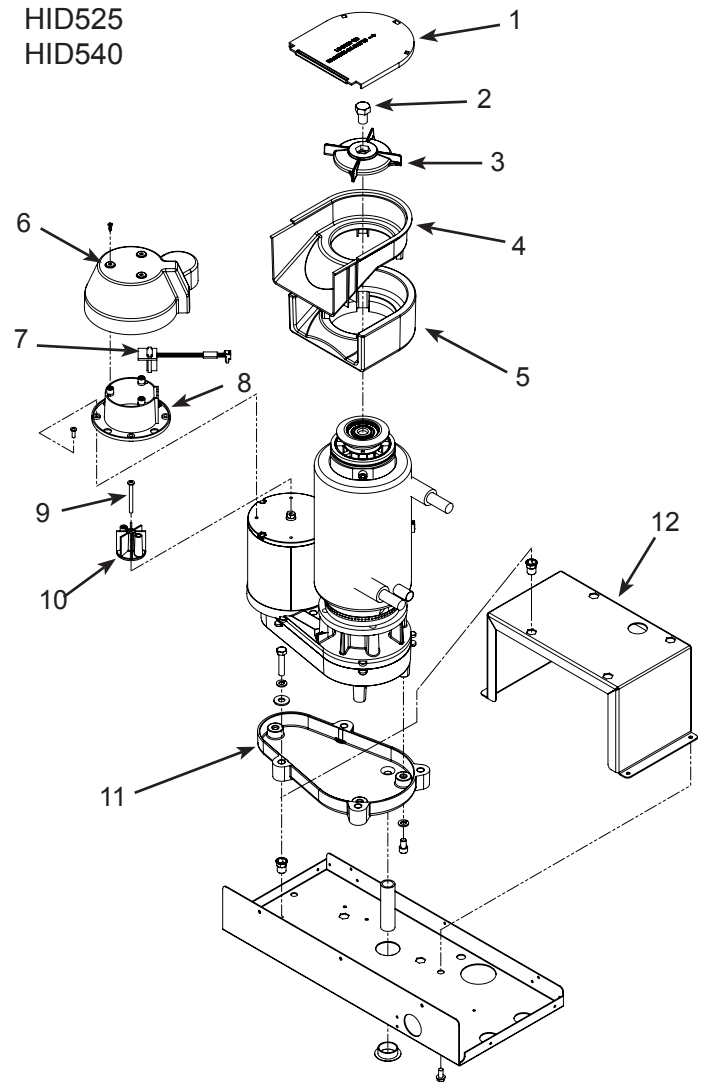

Item Number	Part Number	Description
1	02-4802-01	Cover
2	03-1405-52	Hex bolt
3	02-4745-01	Ice sweep
4	02-4760-01	Chute
5	02-4761-01	Insulation item 4
6	02-4797-01	Motor cover
7	12-3089-01	Rotation sensor
8	02-4791-01	Holder, rotation sensor
9	03-1403-70	Screw, magnet holder to motor
10	02-4791-02	Magnet holder
11	02-4804-01	Condensate pan
12	A40255-001	Support bracket, 540 only
13	02-4873-01	Wrench to hold motor shaft when removing item 9 (see note*)

\*A cordless impact driver can be used to removed or tightened the #9 retaining screw. #13 is an optional thin wrench to hold motor shaft.

# HID312, HID525 and HID540 Service Parts

## Ice Making Components

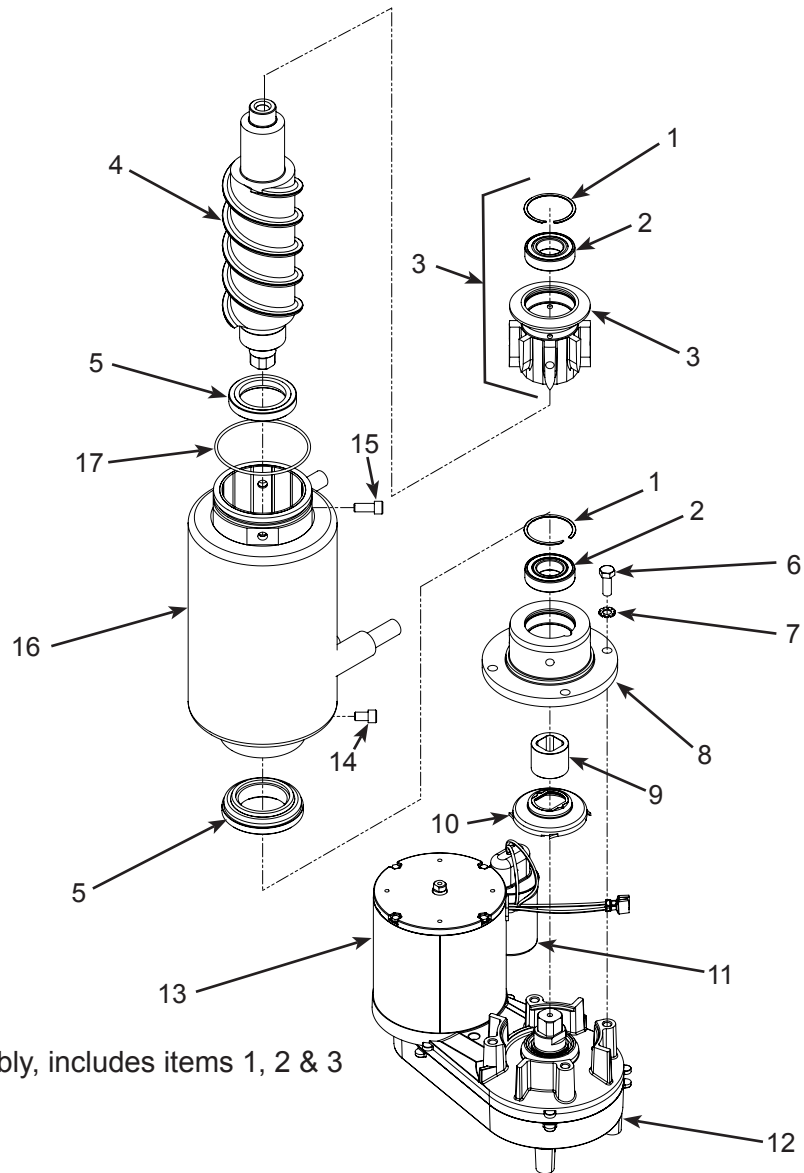

Item Number	Part Number	Description
1	03-3953-01	Retaining ring
2	02-4843-23	Bearing
3	A40173-001	Extruder assembly, includes items 1, 2 & 3
4	02-4840-21	Auger
5	02-0929-23	Water seal
6	03-1405-38	Cap screw
7	03-1417-13	Lockwasher
8	A40174-001	Adapter, includes items 1, 2 and 8
9	02-4838-01	Coupling
10	02-4786-01	Water shed
11	12-3083-24	Capacitor, 115 volt models
	12-3083-25	Capacitor, 50 Hz models
12	12-3083-21	Gear reducer complete, for 115 volt models
	12-3083-22	Gear reducer complete, for 50 Hz models
12a	12-3083-23	Gear reducer, no motor
13	12-3083-31	Auger drive motor, for 115 volt models
	12-3083-32	Auger drive motor, for 50 Hz models
14	03-1544-09	Socket hd cap screw, 1/2 inch long
15	03-1544-08	Socket hd cap screw, 3/4 inch long
16	02-4758-21	Evaporator
17	13-0617-52	O-ring

Note: Bearings and water seal should be replaced as a set. Do not substitute non-OEM bearings. Do not lubricate bearings. Bearings may be pushed out of their retainer.

Remove extruder first to remove auger. Attach ice sweep to lift auger.

Auger motor note: Motor shipped attached to gear reducer cover. Cover not intended for replacement, used only for shipment. Remove motor from cover and discard cover.

12a ships with separate 11 oz oil charge.

# HID312, HID525 and HID540 Service Parts

## Electrical

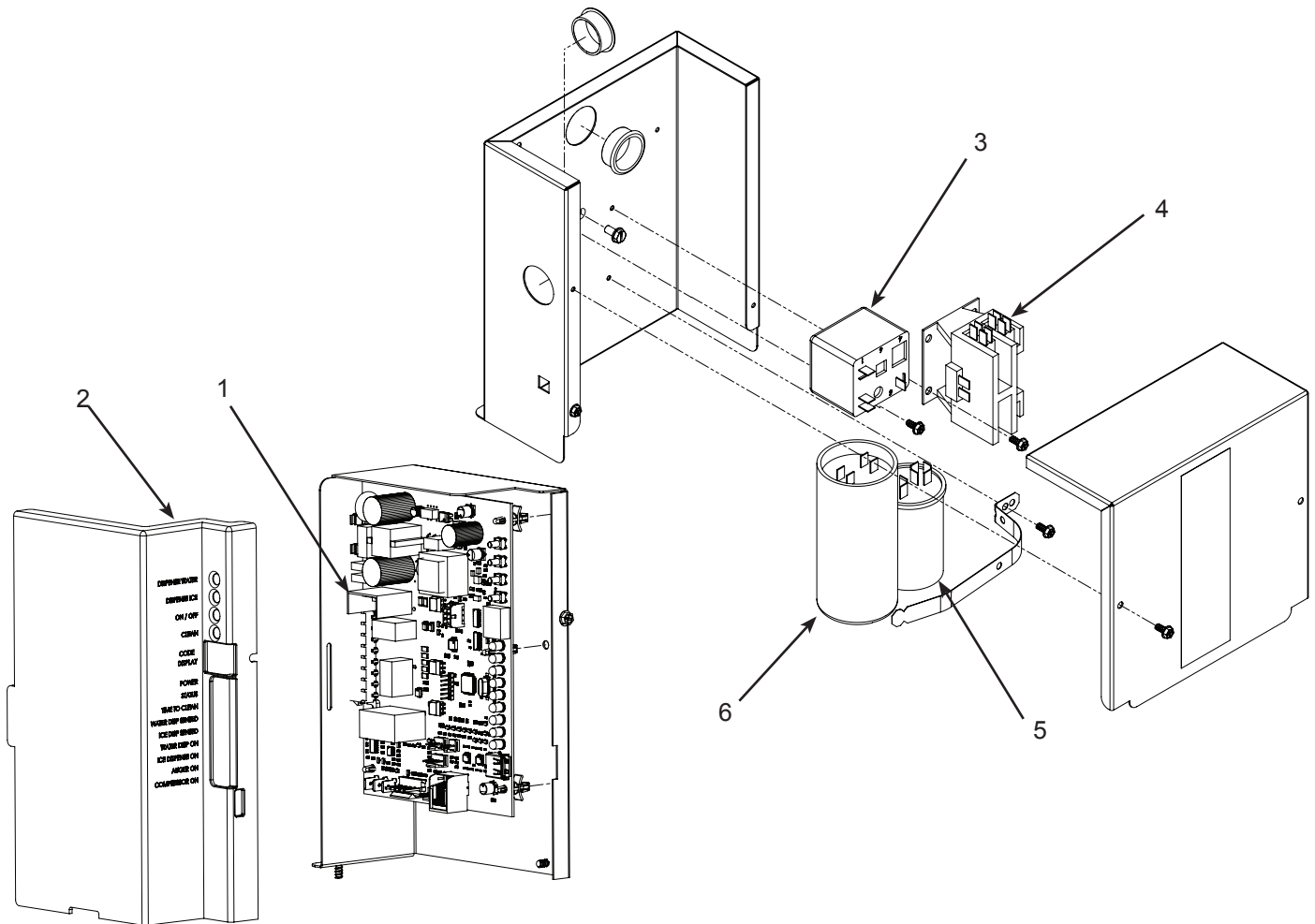

Item Number	Part Number	Description
1	11-0612-51	Controller
1a		Fuse - 8 amp fast acting 5 mm ROHS
2	02-4830-01	Cover
3	18-1903-44	Potential relay, for 525, 540 115 volt
	18-1903-54	Potential relay, for 525, 540 50 Hz
4	12-2469-03	Contactor, 115 volt
	12-2469-02	Contactor, for 50 Hz models
5	18-1902-64	Run capacitor, for 525, 540 115 volt models
	18-1902-65	Run capacitor, for 525, 540 50 Hz models
6	18-1901-65	Start capacitor, for 525, 540 115 volt models
	18-1901-66	Start capacitor, for 525, 540 50 Hz models

### Harnesses

12-1638-27	Power cord, 115 volt
12-1638-28	Power cord, 50 Hz
12-3090-01	High voltage harness
12-3091-01	Disable sw harness
12-3092-01	Sensor harness, dispense
12-3094-02	Bin full sensor harness

# HID312, HID525 and HID540 Service Parts

## Accessories

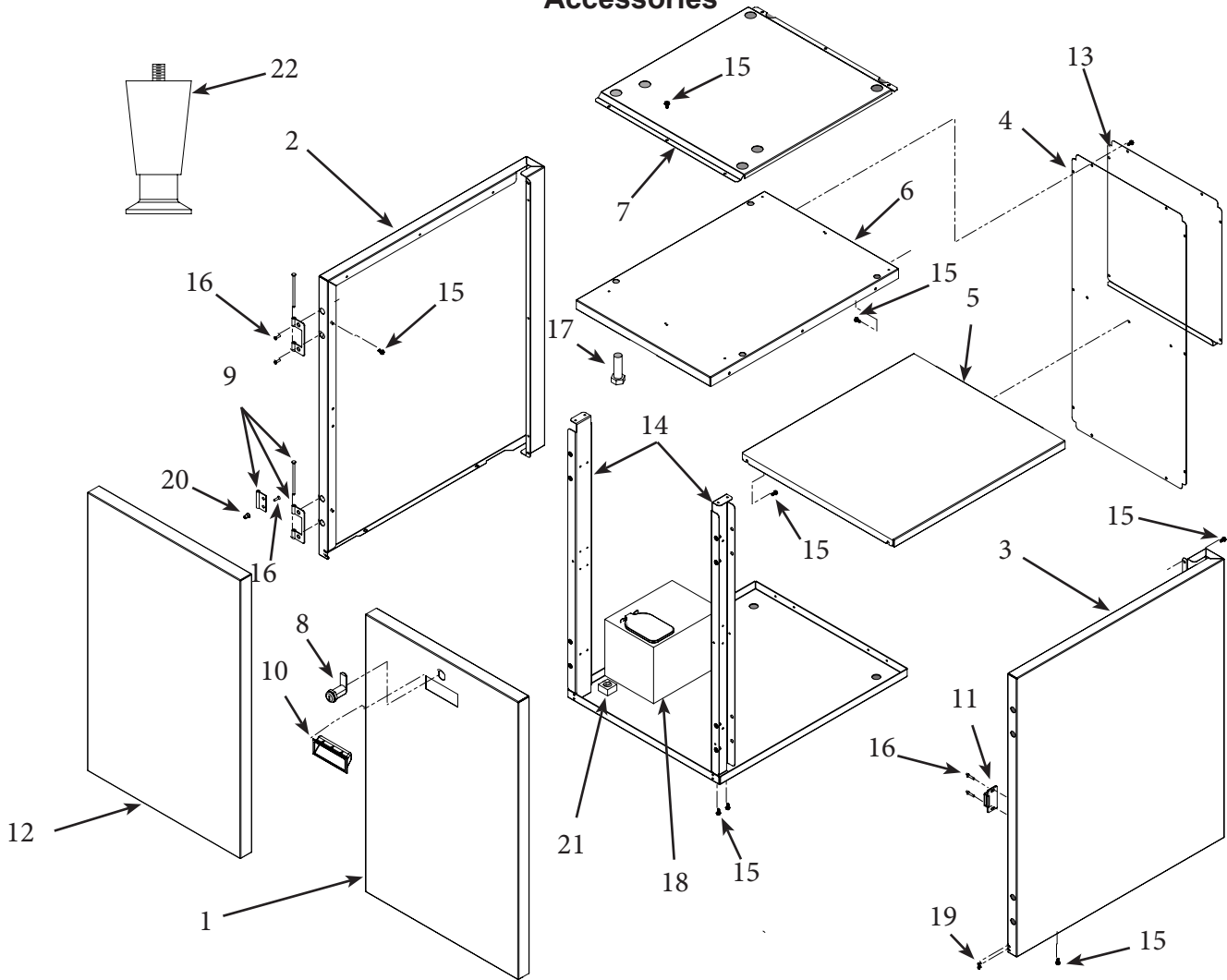

Item Number	Part Number	Description
1	A40347-021	HST16 Door
2	A40345-001	HST16 & HST21 Left Panel
3	A40345-002	HST16 & HST21 Right Panel
4	A40351-001	HST16 Back Panel
5	A40352-001	HST16 Shelf
6	A40346-001	HST16 Top Panel
7	A40350-001	HST16 Machine Support
1	A40347-022	HST21 Door
4	A40351-002	HST21 Back Panel
5	A40352-002	HST21 Shelf
6	A40346-002	HST21 Top Panel
7	A40350-002	HST21 Machine Support
8	03-3955-01	Lock and two keys
9	03-3954-01	Hinge Complete
10	02-4441-01	Door Handle
11	03-3956-01	Magnetic Catch
12	A40458-001	HST16B Front Panel
2	A40345-001	HST16B & HST21B Left Panel

Item Number	Part Number	Description
3	A40345-002	HST16B & HST21B Right Panel
13	A40459-001	HST16B Back Panel
6	A40346-001	HST16B Top Panel
7	A40350-001	HST16B Machine Support
12	A40458-002	HST21B Front Panel
13	A40459-002	HST21B Back Panel
6	A40346-002	HST21B Top Panel
7	A40350-002	HST21B Machine Support
14	A40349-001	Corner Support
15	03-3943-01	Screw #8 X 3/8"
16	03-1418-03	Screw, #6 X 5/8"
17	03-1405-53	Hex Bolt 5/8-11 X 2
18	KLP7	6" Legs for Sand (set of 4)
19	No Number	1/8 Rivet
20	No Number	Rivetnut (Special tool required)
21	03-1674-01	Square Nut 5/8-11
22	KLP24A	4" Legs for Unit (set of 4)

# HID312, HID525 and HID540 Service Parts

## HID325 and HID540 Wiring Diagram

17-3489-01

1 WIRE COLOR FOR 208-230/60/1 AND 115/60/1 UNITS: BLACK  
WIRE COLOR FOR 208-230/50/1 UNITS: BROWN

2 WIRE COLOR FOR 115/60/1 UNITS: WHITE  
WIRE COLOR FOR 208-230/50/1 UNITS: BROWN

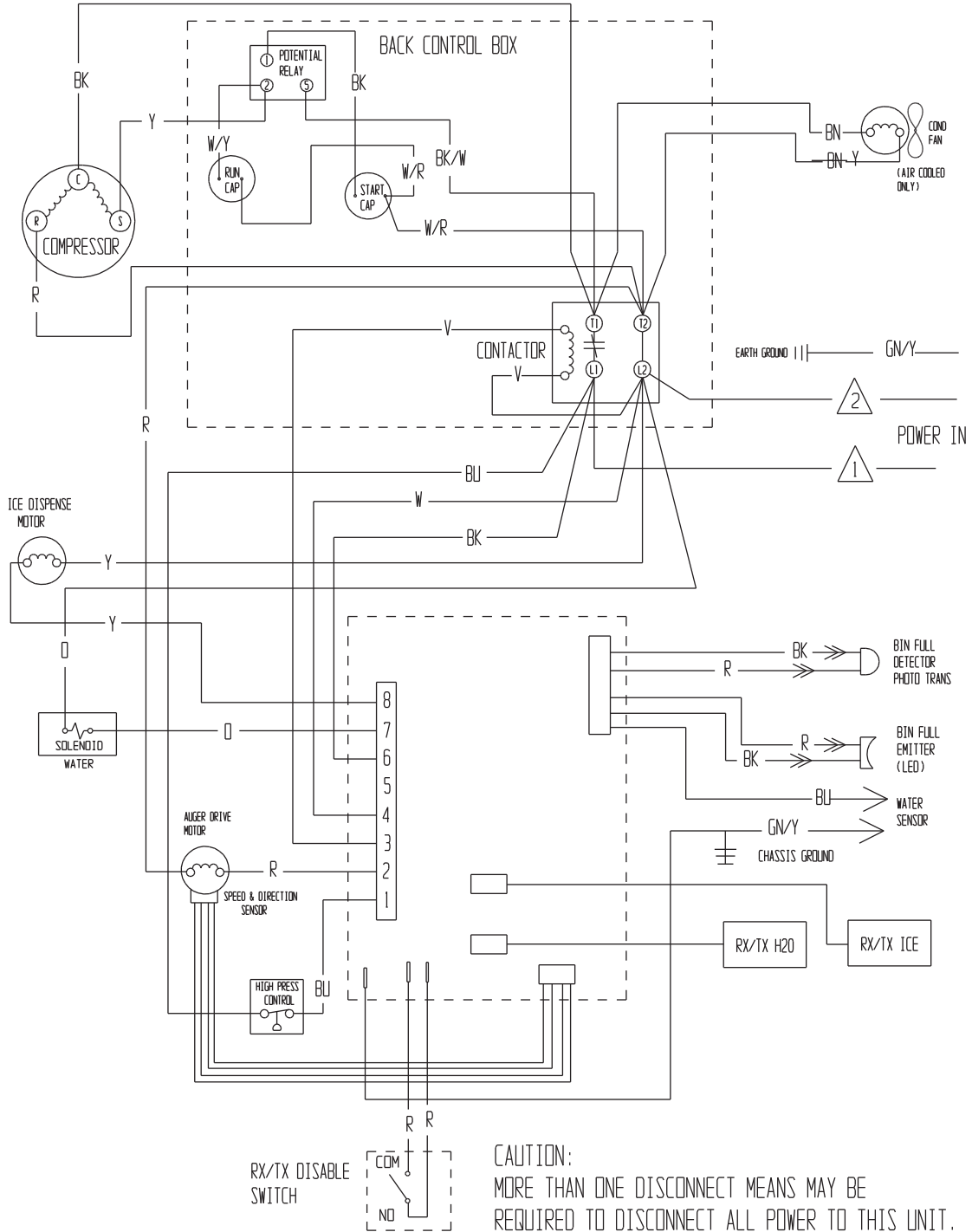

ALL CONTROLS SHOWN IN ICE MAKING MODE  
WITH ALL DISPENSING SYSTEMS IN OPERATION

# HID312, HID525 and HID540 Service Parts

## HID525 and HID540 Schematic Diagram

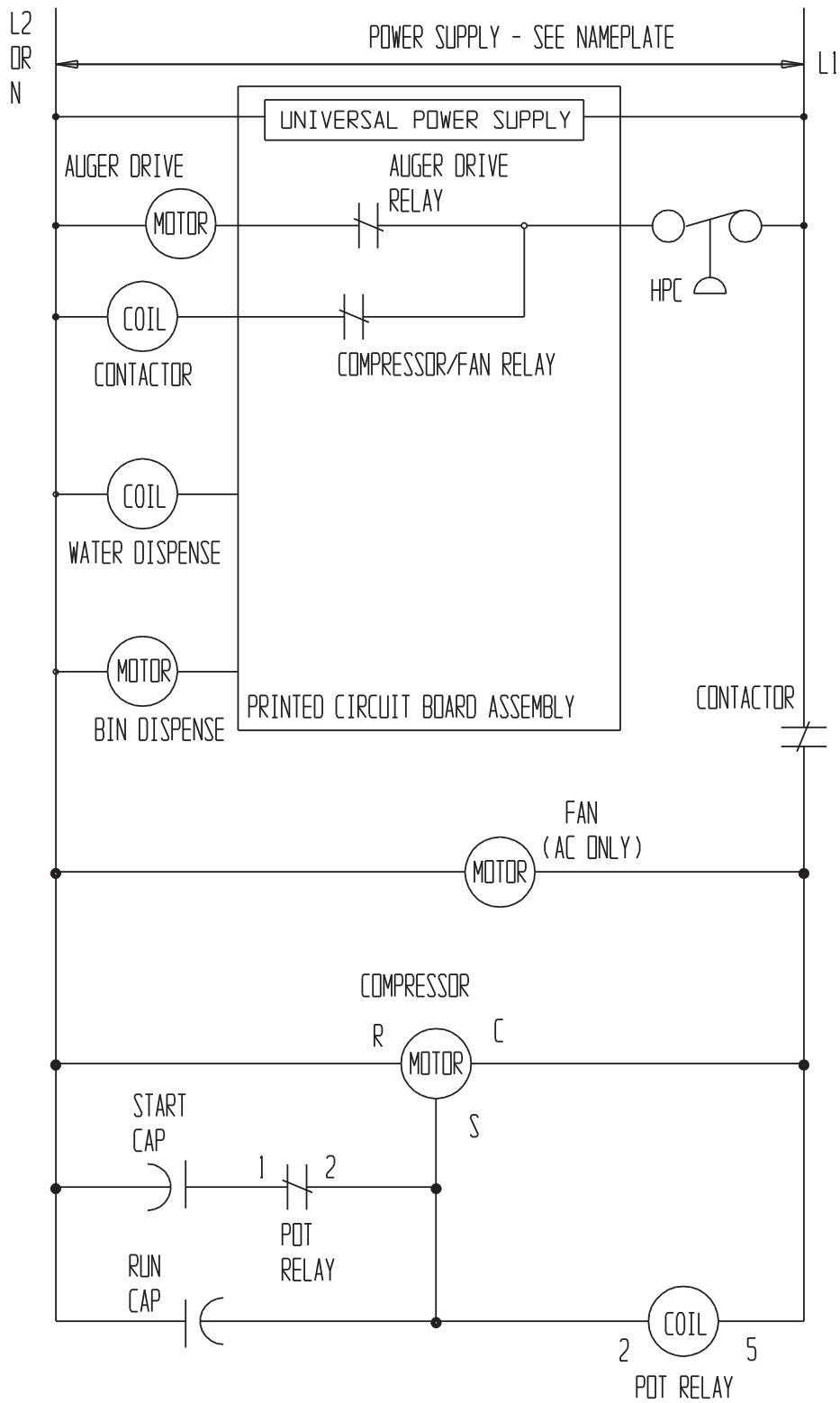

ALL CONTROLS SHOWN IN ICE MAKING MODE  
WITH ALL DISPENSING SYSTEMS IN OPERATION



# HID312, HID525 and HID540 Service Parts

## HID312 Wiring Diagram

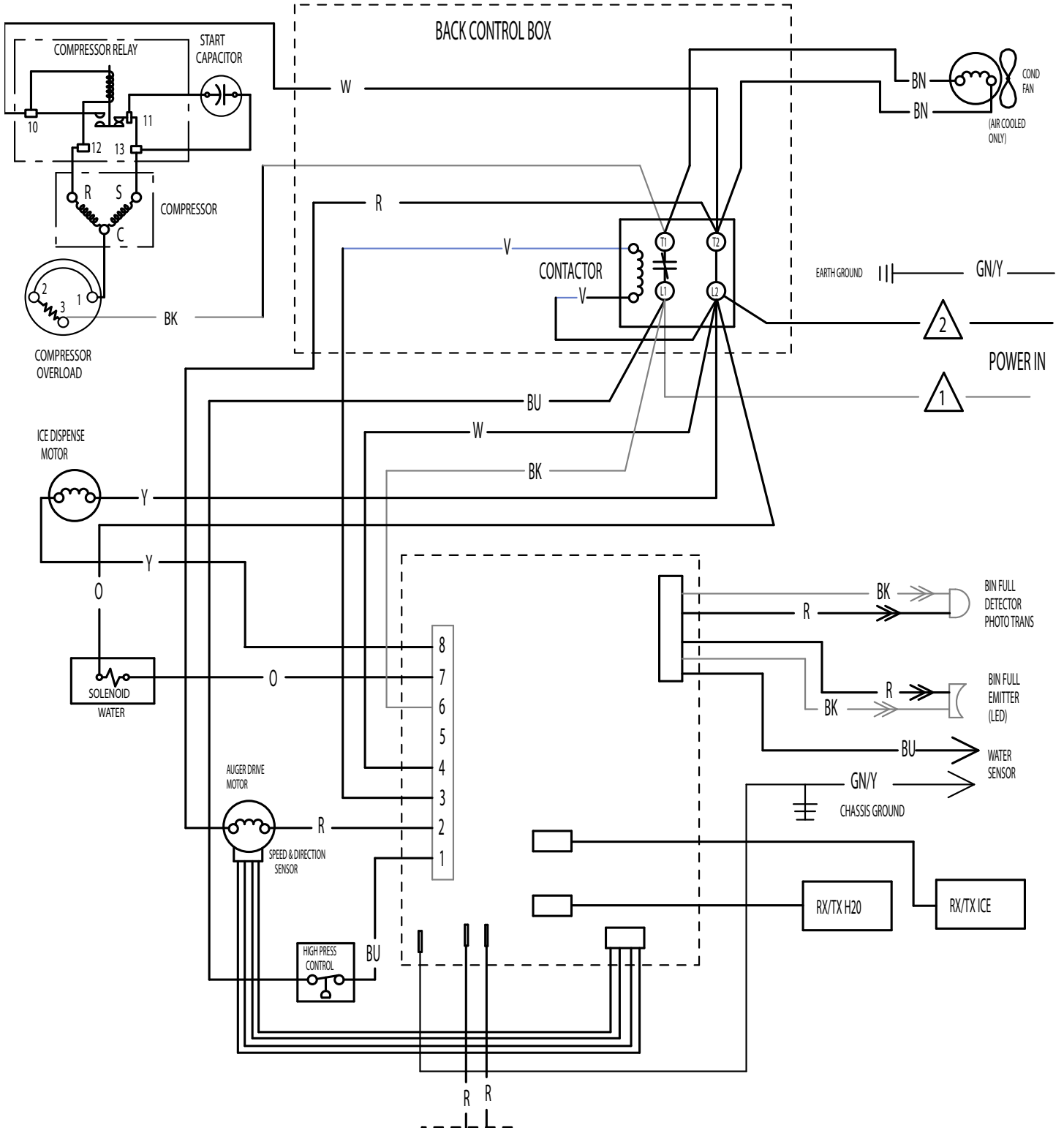

# HID312, HID525 and HID540 Service Parts

## HID312 Schematic Diagram

