

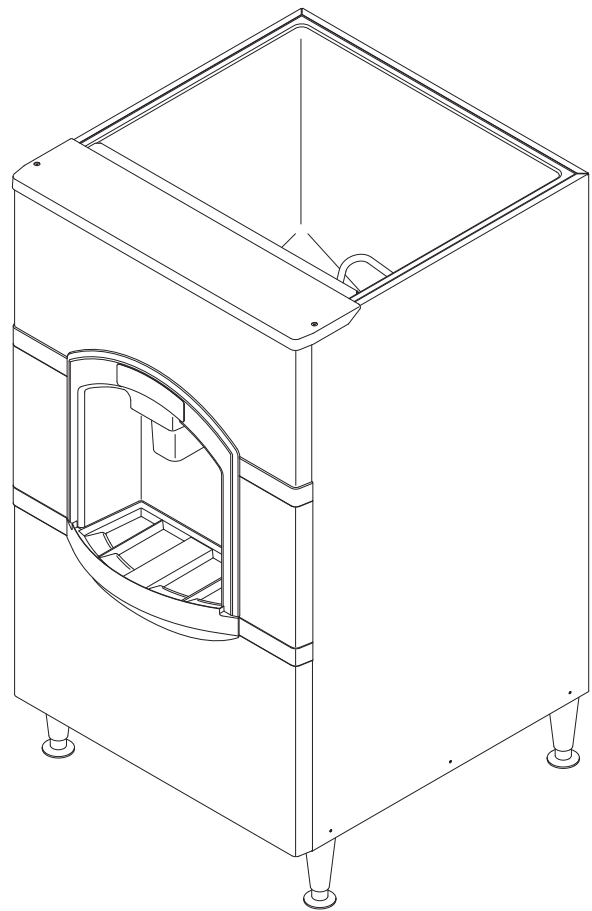

Product Manual for Ice Dispensers
Models **HD22** and **HD30**

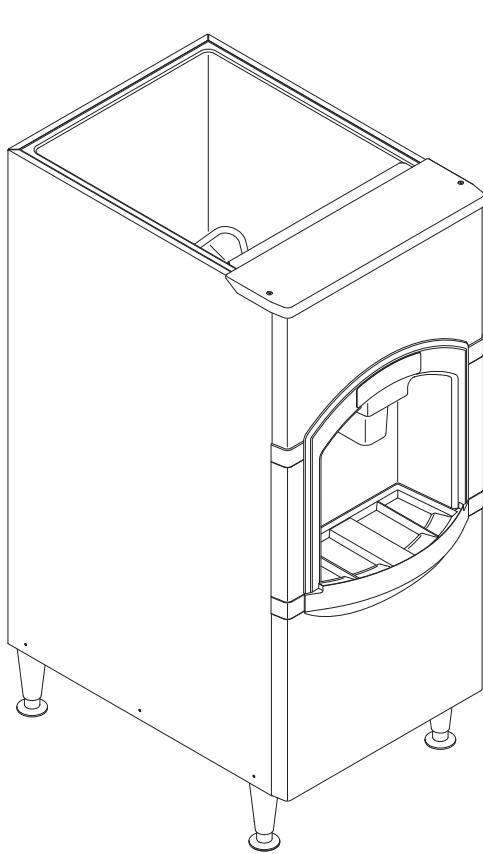

Introduction

To the owner or user: This product manual is a source of information about the installation, start up, cleaning, maintenance and repair of the product.

Table of Contents

Introduction	Page 1
General Description	Page 2
Specifications & Limitations	Page 3
HD30 Dimensioned Illustration	Page 4
HD22 Dimensioned Illustration	Page 5
Product Description	Page 6
Unpacking	Page 7
Installation - Plumbing	Page 8
Installation - Electrical and Ice Machine Assembly	Page 9
Final Check List/Initial Start Up	Page 10
Use	Page 11
General Care and Cleaning	Page 12
General Care And Cleaning - Continued	Page 13
Maintenance	Page 14
Adjustments	Page 15
Service Diagnosis	Page 16

HD22 and HD30

General Description

The HD22 is a hotel/motel ice dispenser. It is designed to use a Scotsman C0322 or C0522 cube ice machine as the source for ice.

The HD30 is a wider version of the HD22 and is designed to use a Scotsman C0330 or C0530 cuber as its source of ice. Additional models may be used, see sales information for details. Flaked or nugget ice is not recommended for use in these dispensers.

Ice from the cuber falls into the insulated hopper, where it is stored until needed. When a user pushes the dispense chute a rotating wheel scoops the ice up to the top front of the hopper where there is an outlet to the ice chute.

Cuber Model	Fits Dispenser	Adapter
C0322	HD22	None Needed
C0522 or CB0522	HD22	None Needed
C0330 or CB0330	HD30	None Needed
C0530 or CB0530	HD30	None Needed

* Higher capacity cubers, C0630 or C0830, may also be used, but they require 230 volt power.

Basic Specifications

Model	Dimensions w" x h" x d" with 6" leg	Basic Electrical volts/hertz/phase	Model Description	Bin Storage Capacity, ARI rated
HD22B-1A	22 x 53 x 33 ½	115/60/1	Basic 22" model, 60 Hz	120 lb
HD22B-6A	22 x 53 x 33 ½	230/50/1	Basic 22" model, 50 Hz	120 lb
HD30B-1A	30 x 53 x 33 ½	115/60/1	Basic 22" model, 60 Hz	180 lb
HD30W-1A	30 x 53 x 33 ½	115/60/1	Water station model	180 lb
HD30B-6A	30 x 53 x 33 ½	230/50/1	Basic 30" model, 50 Hz	180 lb

All 60 Hz models are supplied with an 11' power cord, 50 Hz models have a 1.1 meter power cord. Basic models dispense ice when their chute is pushed. Coin/token models discontinued in 2011.

Specifications & Limitations

This dispenser is designed to be installed and operated indoors, in a controlled environment. Its minimum and maximum operating temperature limits are the same as those for the ice machine.

	Minimum	Maximum
Air Temp	50°F.	100°F.
Voltage 60 Hz	104	126

Check the nameplate, located on the back of the cabinet for specific information.

Scotsman reserves the right to make design changes and/or improvements at any time.

Specifications and designs are subject to change without notice.

Scotsman assumes no liability or responsibility of any kind for products manufactured by Scotsman that have been altered in any way, including the use of any parts and/or other components not specifically approved by Scotsman.

Models

There are two versions of the HD30 dispensers: Basic and Water Station. The Basic version is constructed to deliver ice when the ice chute is pushed in, and it continues to vend ice as long as the ice chute is held in.

The Water Station version is a Basic version with a mechanical water faucet added to the left of the ice chute. Water is dispensed whenever the faucet lever is pushed back. The HD30 is available in all versions, the HD22 is only available as a Basic model.

50 Hz.

The Basic models of the HD22 and HD30 are available in 230 volt 50 Hz electrical for those countries with that type of electrical service.

HD22 and HD30

HD30 Dimensioned Illustration

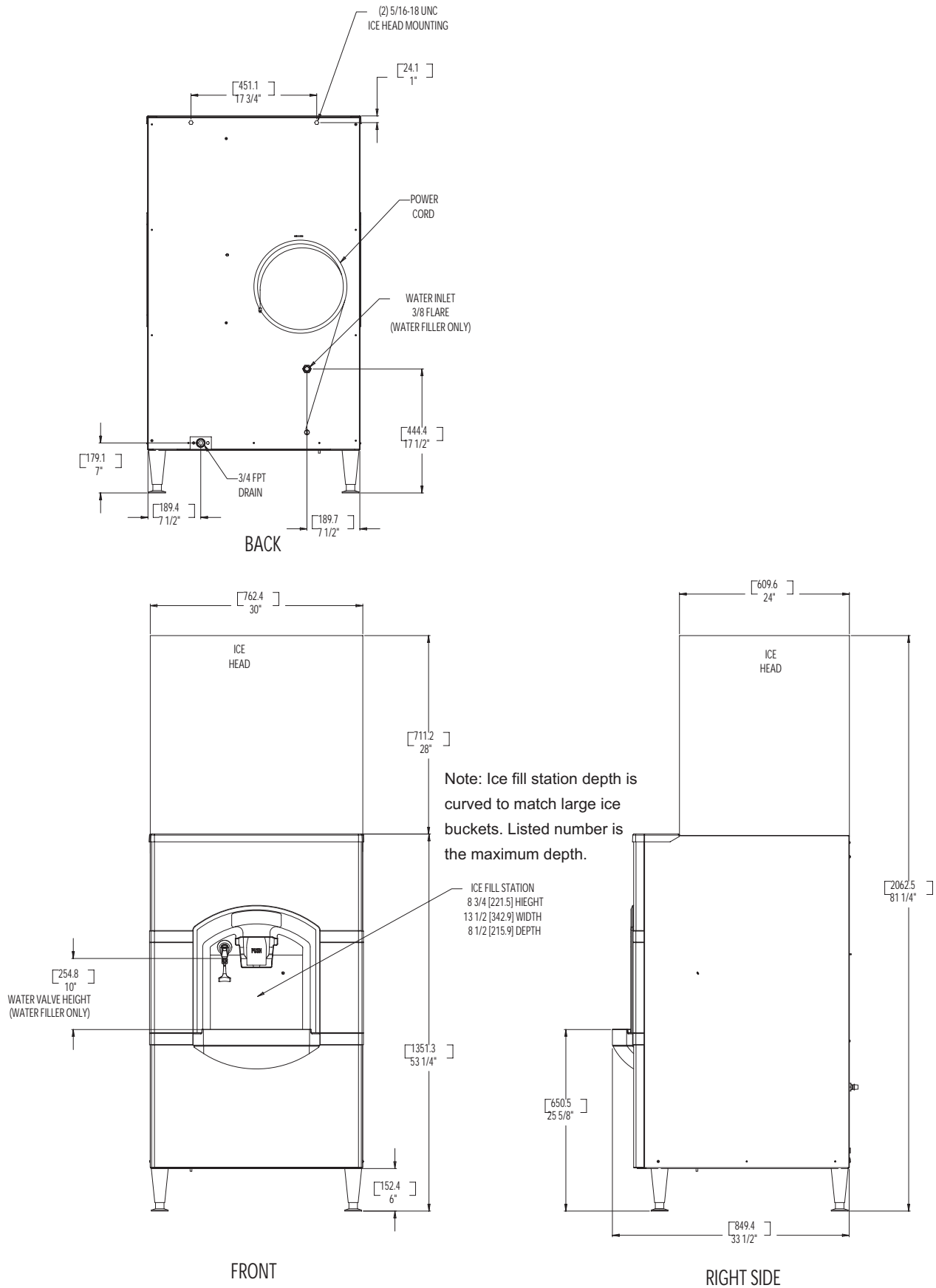

HD22 Dimensioned Illustration

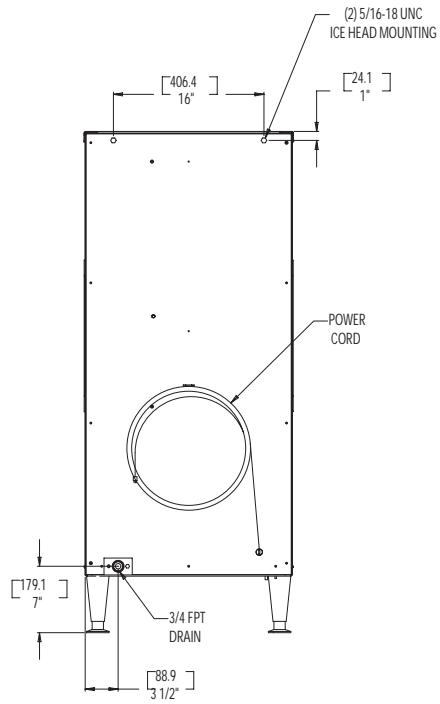

BACK

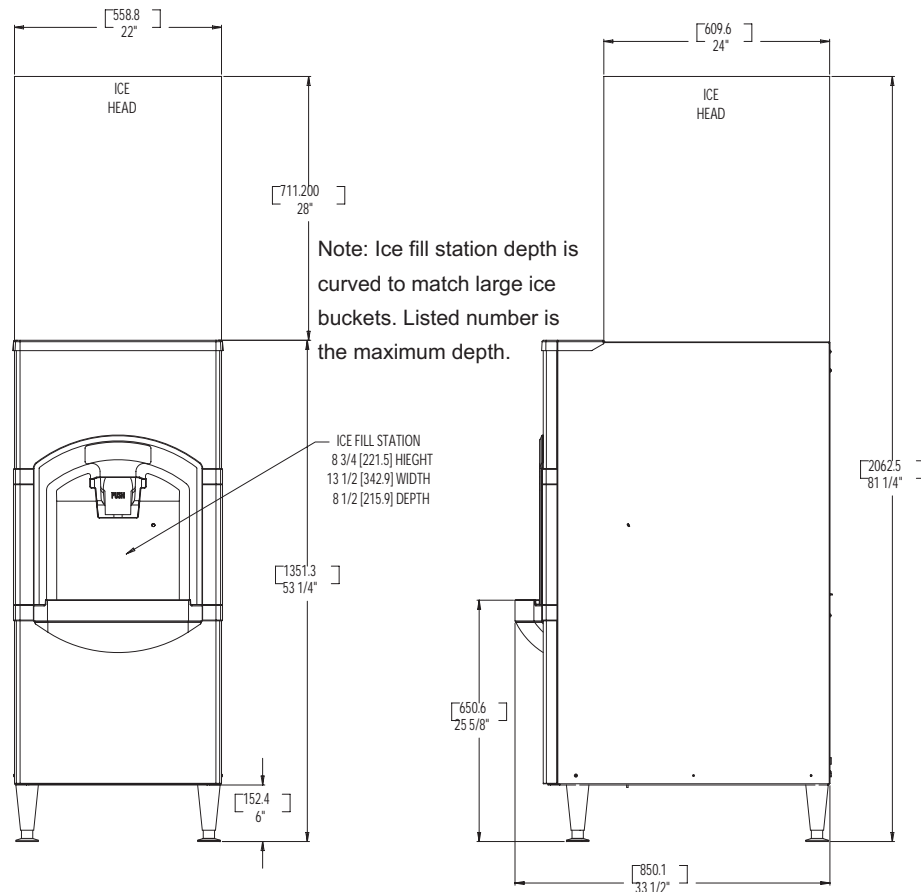

FRONT

RIGHT SIDE

HD22 and HD30

Product Description

All models consist of a plastic lined, insulated hopper mounted to a metal base. The hopper contains a 15 blade plastic dispense wheel and a stainless steel sweep arm. The top front of the hopper has a removable door to facilitate maintenance and cleaning of the hopper without removal of the ice machine.

The dispense wheel and sweep arm rotate when the dispense drive motor is actuated. The drive motors actuation is controlled by the agitation timer or the vend switch. When the ice dispense chute is pushed back it moves the actuation lever up. The actuation lever releases the chute door and pushes the vend switch arm up. When the vend switch arm has moved a preset distance the vend switch contacts close, providing power to the dispense drive motor. Ice is delivered to the top end of the ice chute by the dispense wheel and it slides down the chute to the container below.

The container rests on a grill, the grills openings are over the ice catch pan, and any spilled ice goes there. The grill has a flange at the front to help contain the ice if it spills during vending. After the ice dispense chute is released, the ice chute door closes to stop ice flow. Ice in the chute will eventually melt. Melted ice water is routed to the drain through a hose attached to the bottom of the chute. Spilled ice is contained in an insulated ice catch pan. Melted ice water from the ice catch pan is routed to the drain. User debris is kept away from the drain in the catch pan by a slotted shield.

The side and front exterior panels are stainless steel. The vending area and top panel are made of plastic.

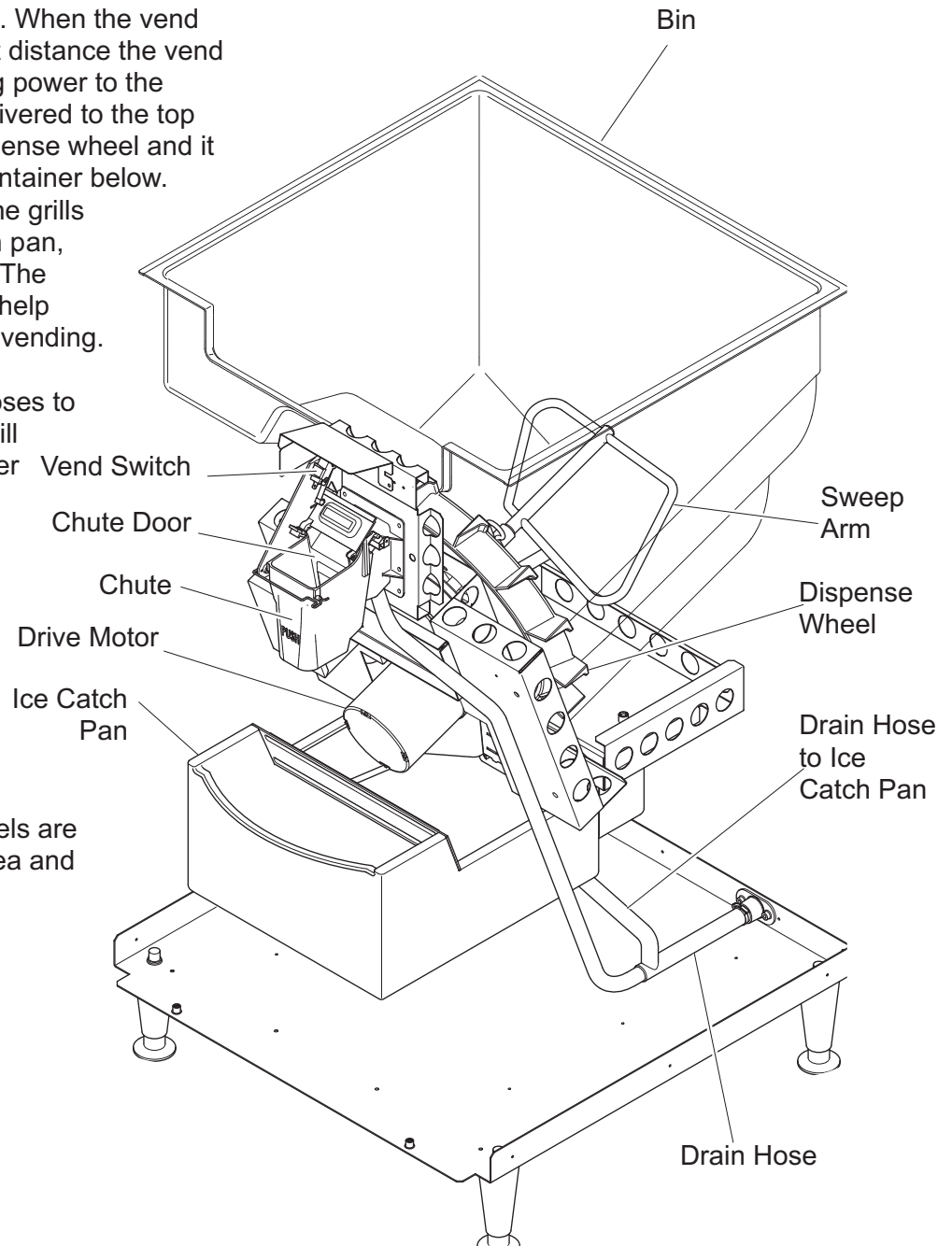

Unpacking

After removing the carton, check for the loose-shipped parts packed in the storage bin. The parts will include a carton with four legs. Remove the leg carton and any other loose-shipped items.

To remove the skid, place part of the carton behind the unit and tip the unit on its back. Remove the bolts holding the skid to the base of the HD dispenser and separate the skid from the unit.

Install the legs into the base of the unit, using the holes where the skid bolts were. Turn the leg leveler part of the legs in all the way, adjust them later after the unit is in its final installed position.

Move the dispenser to an upright position and set it in the location where it will be installed. Note where drain lines and electrical connections will be made.

Front Panel Removal

The front panel rests on the base and is located with pins that stick up from the base. It is retained to the side panels by strikes and latches. The top panel keeps the front panel from moving forward.

To remove:

1. Disconnect electrical power.
2. Remove the two screws holding the top panel to the dispenser. Lift the top panel up and off the dispenser.
3. Pull the top edge of the front panel forward until the two snaps disengage.
 - If the unit is a coin op model, reach behind the front panel and disconnect the coin mechanism harness from the front panel.
 - If the unit is a water station model, reach behind the front panel and shut off the water supply valve to the water faucet. Then disconnect the water line from the shut off valve.
4. Lift the front panel up and off the base.

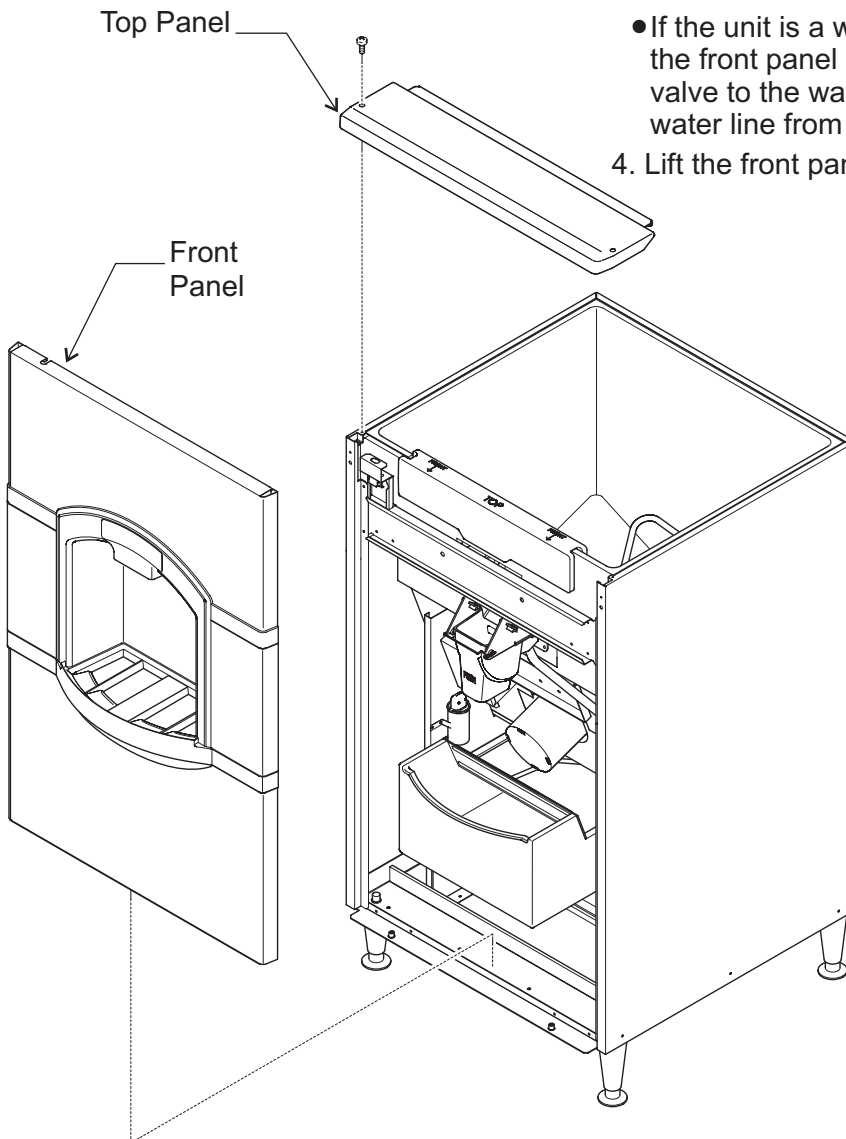

HD22 and HD30

Installation - Plumbing

Drain:

All models of the dispenser have a 3/4" FPT drain fitting at the bottom of the back panel. Connect 3/4" rigid tubing to this connection, a vent is recommended for most installations. Route the drain tubing to the building drain.

Note: Drain fitting material is plastic. If using copper, sweat the copper tube to copper fitting together before installing on the dispenser.

Note: Keep PVC solvent away from all plastic parts of the dispenser.

Follow all applicable plumbing codes.

Because the drain tubing will be very cold, insulation is recommended for the tubing.

Water:

HD30 water station models must be connected to a source of potable water.

The water supply must have adequate backflow protection to comply with applicable codes.

Flush the water supply line before connecting it to the dispenser.

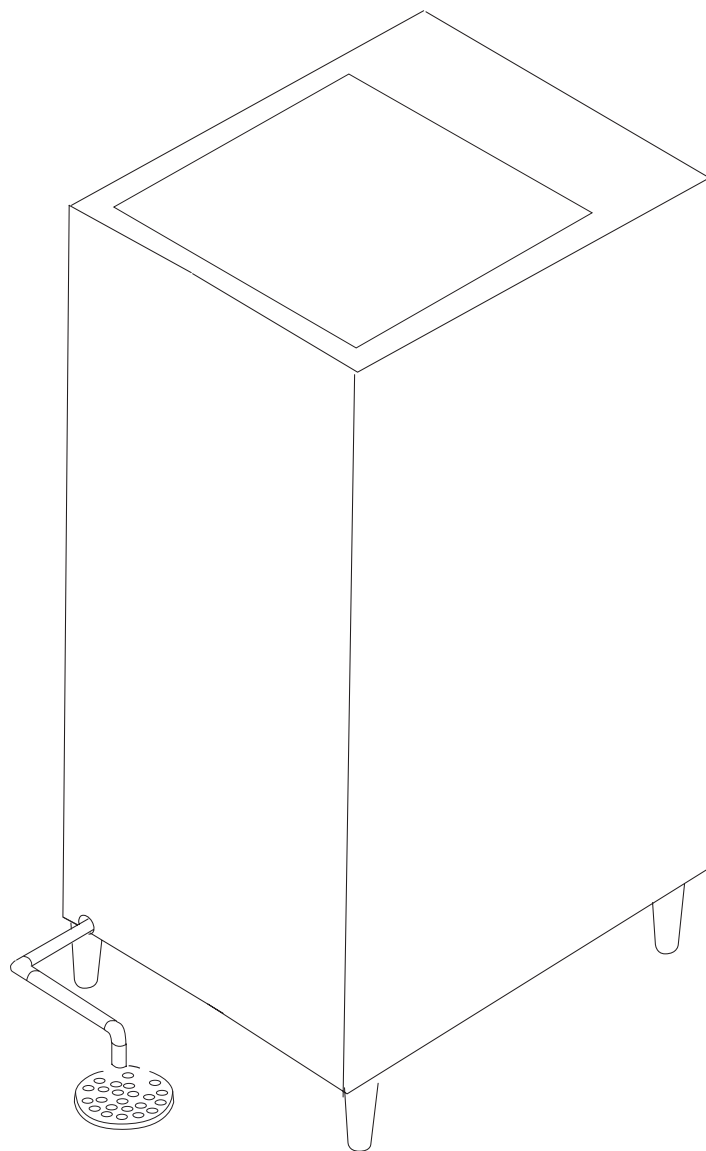

Drain Connection, Back View of Dispenser

Installation - Electrical and Ice Machine Assembly

The dispenser is supplied with a power cord. Do not use with an extension cord. The unit must be plugged into a properly grounded outlet.

The dispenser must be installed so that it is a separate piece of equipment from the ice machine. The drains and electrical supply must be separate.

Follow All Local State and National Codes

Ice Machine

All models: Place the dispenser in the location where it will be used. Level the top edge of the dispenser front to back and left to right.

Sanitize the dispenser bin with a locally approved sanitizer. See page 13.

Place the ice machine on the dispenser and secure it to the dispenser with the hardware and straps from the ice machine. Install it according to the instructions in the manual included with the ice machine.

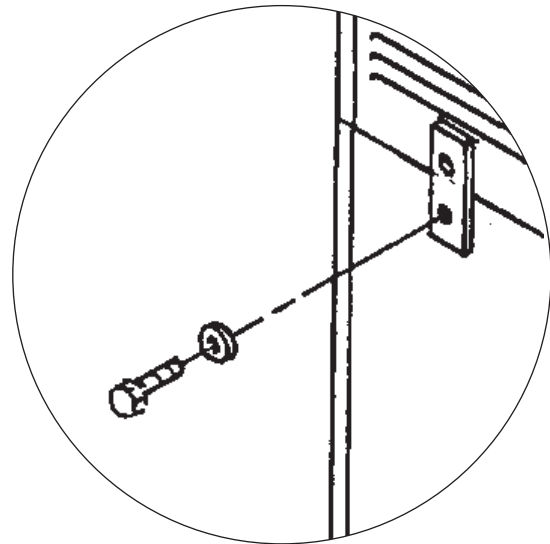

Fasten Ice Machine to Dispenser

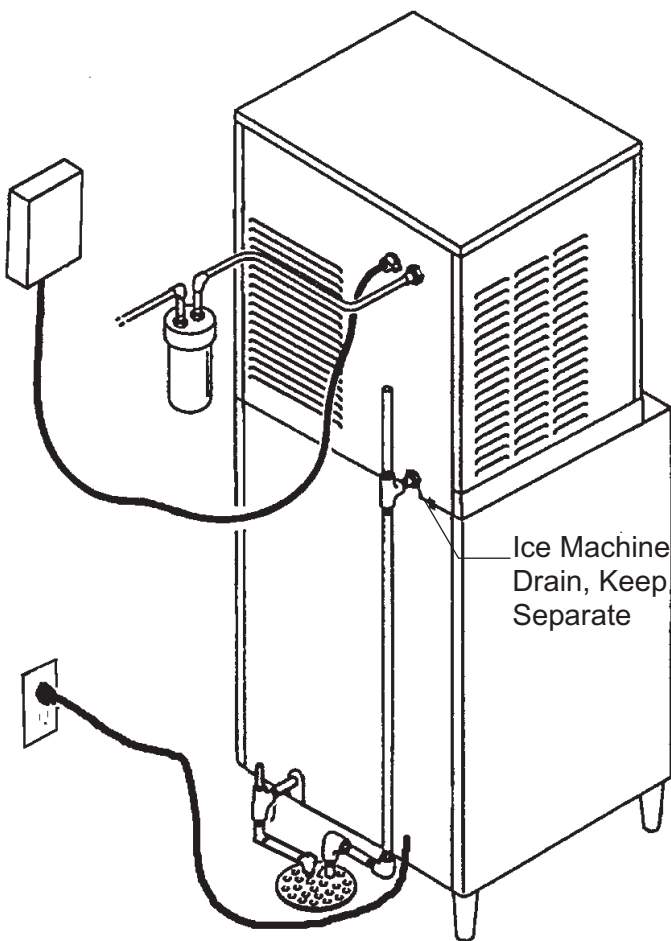

Back View of HD30 Installation

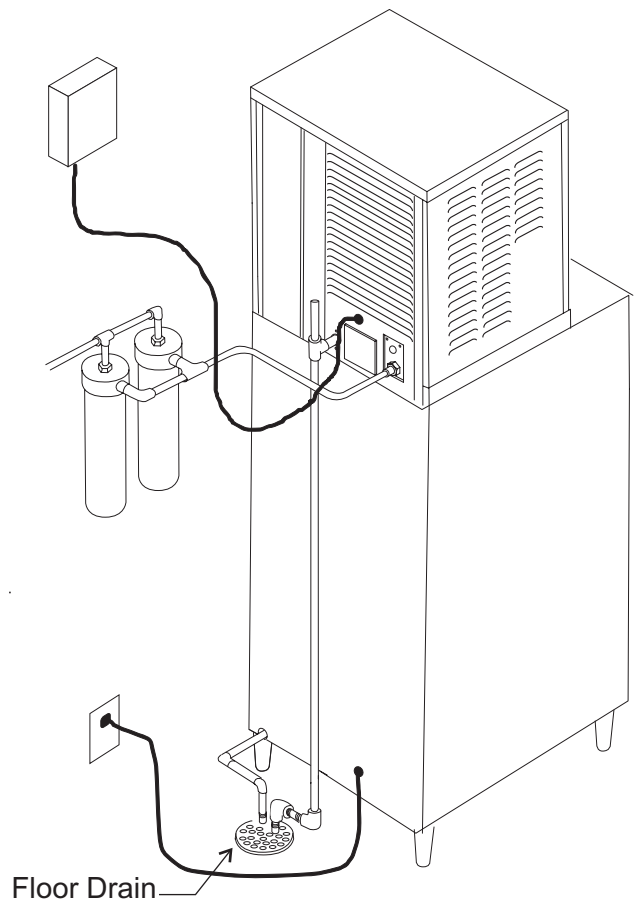

Back View of HD22 Installation

HD22 and HD30

Final Check List/Initial Start Up

1. Check that electrical power has been supplied.
2. Check that a drain, separate from the ice machine, insulated and made of rigid tubing, has been connected to the dispenser.
3. Check that the ice machine has been properly installed per the ice machines installation directions.
4. Check that the ice machine/dispenser assembly is level front to back and left to right.

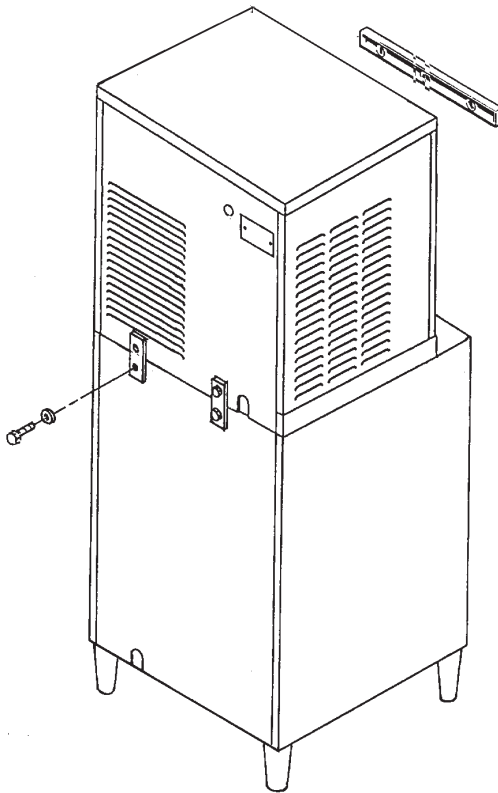

5. Check that optional kits, if any, have been correctly installed.
6. Check that the coin box access key, if used, is available.

To Start:

1. Connect electrical power. The dispensing system will cycle on for a few seconds.
2. Go thru ice machine start up procedures. Let ice machine make two harvests.

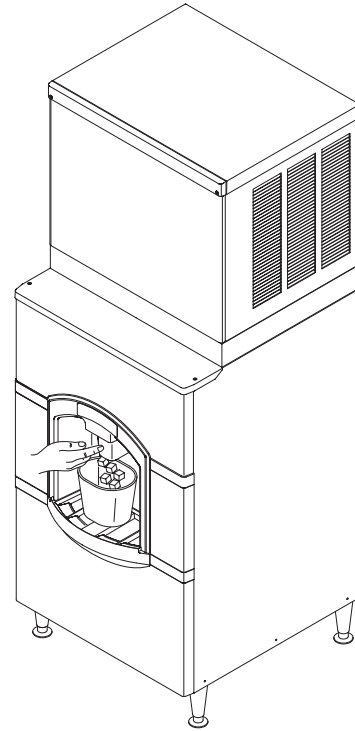

3. Push the ice chute in.
4. Dispense wheel turns.
5. Ice will be dispensed from ice chute.
6. Fill out the warranty registration form and place it in the mail.
7. Give the operator any keys and the instructions on the operation and maintenance of the product.

Check that the operator knows who to call for service, and has the product/service manuals for the machines.

Electrical Sequence

Pushing the ice chute closes a contact to the gear motor.

The gearmotor will have power and the dispenser will continue to operate as long as the ice chute is pushed in. This model also has a agitation cycle of 3 seconds every 6 hours. Since the ice chute is not pushed in during agitation no ice is dispensed.

Use

Basic Model

After the ice machine has operated for a few hours, the HD dispenser can be used. Pushing the ice chute back will activate the dispense mechanism and ice will drop out of the chute into the users container.

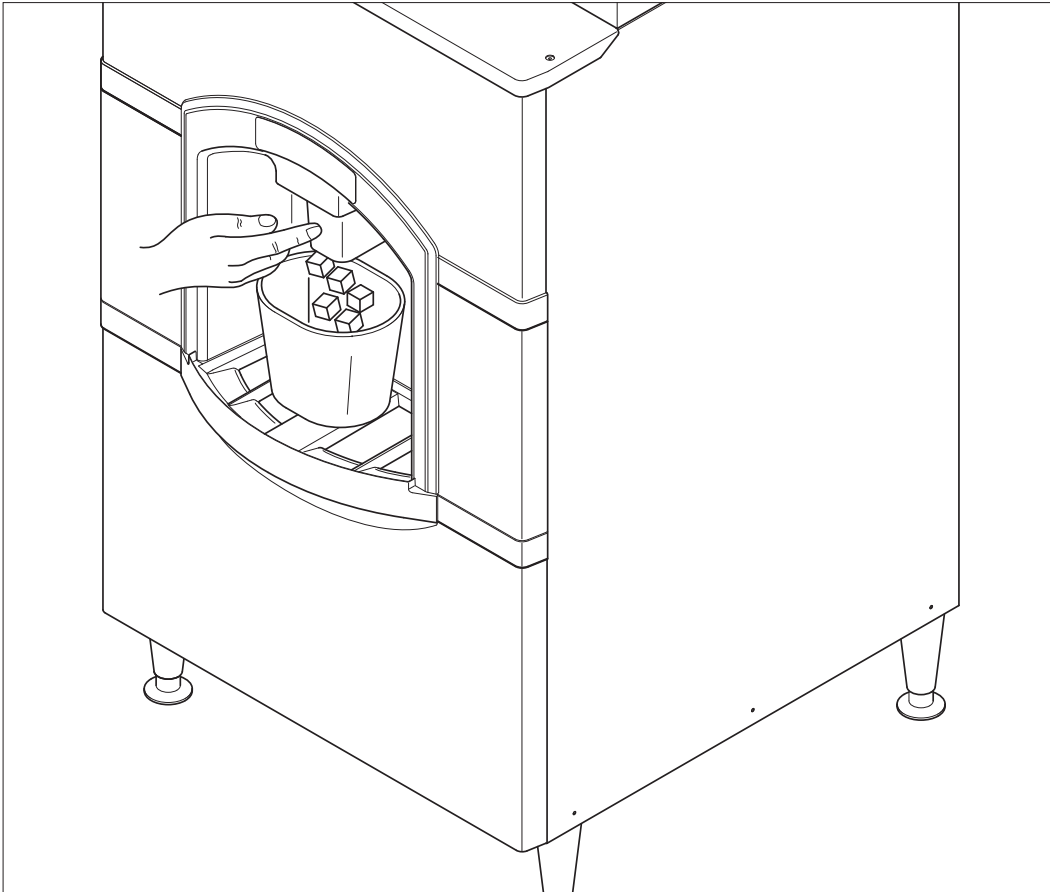

Push the chute back to dispense ice

HD22 and HD30

General Care and Cleaning

Periodically inspect and clean the ice dispenser to keep it operating at peak performance.

Wash the outside of the dispenser with warm water and soap. Rinse off and wipe dry.

Cleaning and Sanitizing of the Ice Storage Bin:

The minerals, chlorine and other impurities in the water are rejected from the water during the freeze cycle of the ice machine. These minerals will collect in the storage bin. The ice storage bin should be cleaned and sanitized every 90 days.

1. Remove all of the ice stored inside the dispenser bin and shut off the ice maker.
2. Disconnect electrical power to the dispenser.

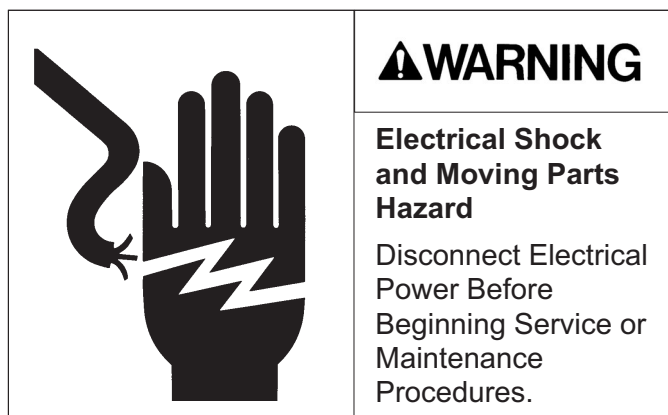

3. Remove top front panel (in front of ice machine).
4. Remove the front panel.

5. Lift up and remove the access door at the front of the bin
6. Reach into the opening, locate the hair pin and pull it out of the shaft
7. Pull the sweep arm off the shaft and remove it from the dispenser.
8. Pull the dispense wheel off the drive shaft and remove it from the dispenser.
9. Mix a solution of 5 ounces of ice machine cleaner to 1 gallon of warm (95°F.-115°F.) water. Wash the entire bin area and the delivery area. Use a clean brush or cloth.

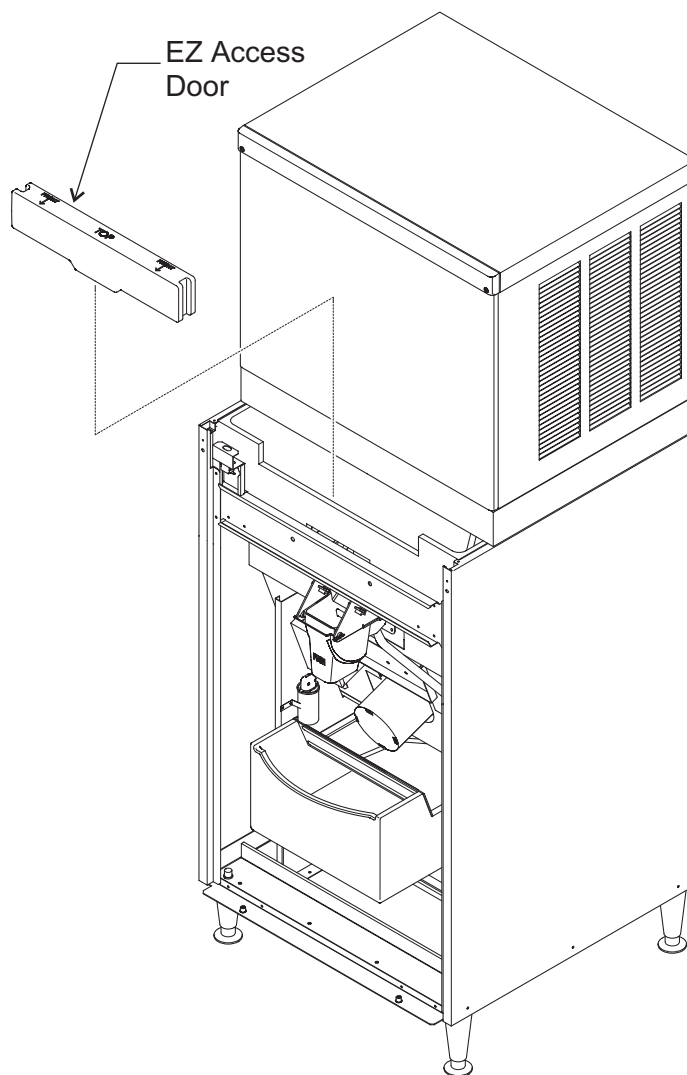

General Care And Cleaning - Continued

10. Rinse all areas washed with clean, fresh water.

11. Using the ice machine cleaning solution, clean the ice grill, sink, sweep arm and dispense wheel. Rinse these parts with clean, fresh water.

12. To sanitize: Use a locally approved sanitizer. A possible sanitizer: Mix a solution of ice machine sanitizer and water: 1 ounce of household bleach to 2 gallons of (95°F.-115°F.) water. Wash all interior surfaces, the sweep arm and the dispense wheel with the sanitizer solution. Use a clean cloth.

13. Allow the parts to air dry.

14. Reassemble wheel and sweep arm onto drive shaft. Be sure to reinsert hairpin.

15. Replace all panels.

16. Reconnect power, be sure ice machine is switched back on.

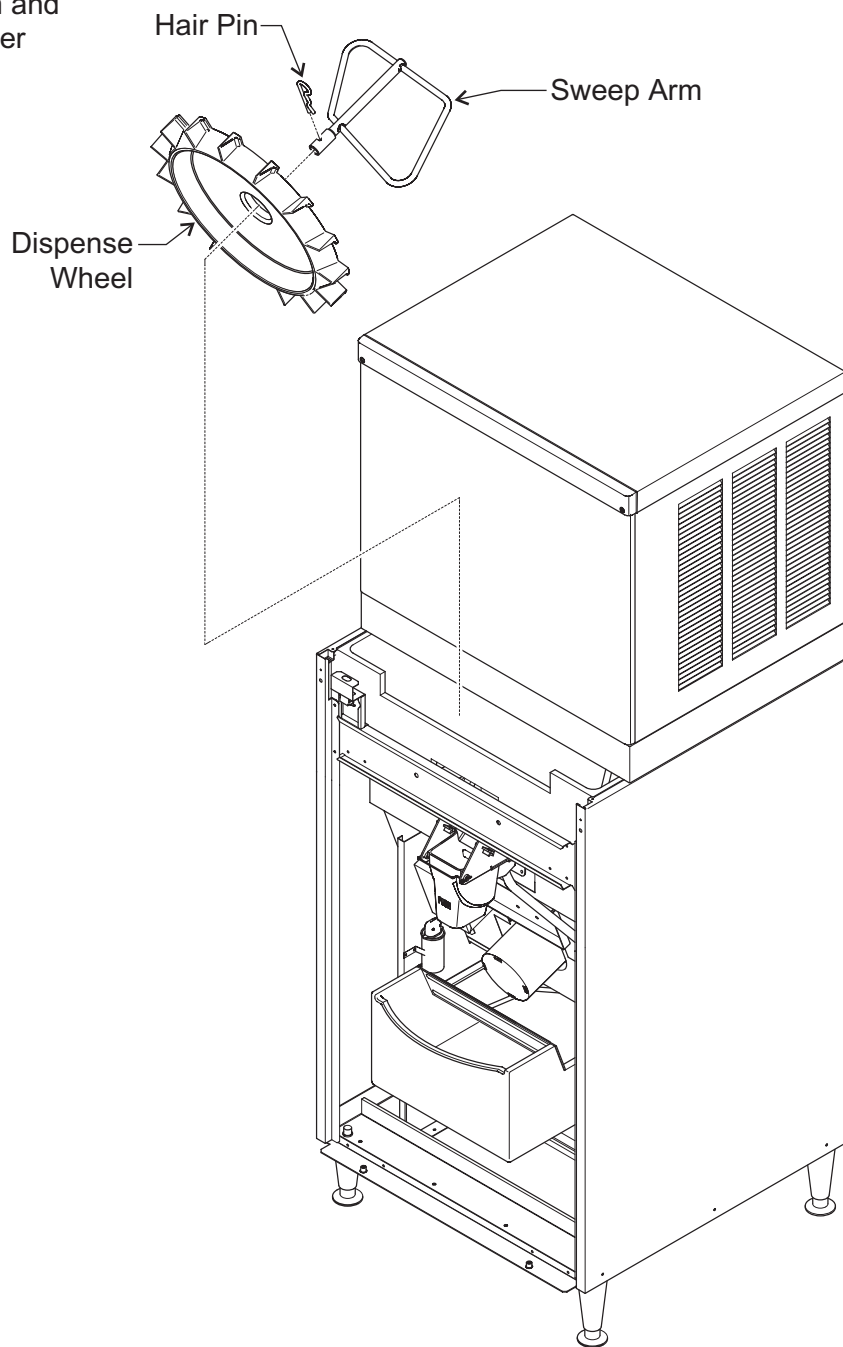

HD22 and HD30

Maintenance

Spilled ice and user debris will collect in the ice catch pan, located just below the sink grill. Occasionally the debris will need to be removed and the drain flushed out to prevent water back ups.

Note: Failure to clean out the ice catch pan will likely result in a water leak, one that is NOT covered by warranty.

To clean out the ice catch pan:

1. Remove the front panel.
2. Disconnect electrical power.
3. Remove the two screws holding the top panel to the dispenser. Lift the top panel up and off the dispenser.

4. Pull the top edge of the front panel forward until the two snaps disengage.

If the unit is a coin op model, reach behind the front panel and disconnect the coin mechanism harness from the front panel.

If the unit is a water station model, reach behind the front panel and shut off the water supply valve to the water faucet. Then disconnect the water line from the shut off valve.

5. Lift the front panel up and off the base.
6. Pull the ice catch pan forward a few inches until the drain hose can be reached.
7. Pull the drain hose from the ice catch pan.
8. Slide the ice catch pan out of the ice dispenser and clear it of any debris. Wash out the drain.
9. Return the ice catch pan to its normal position.
10. Re-attach the drain hose.

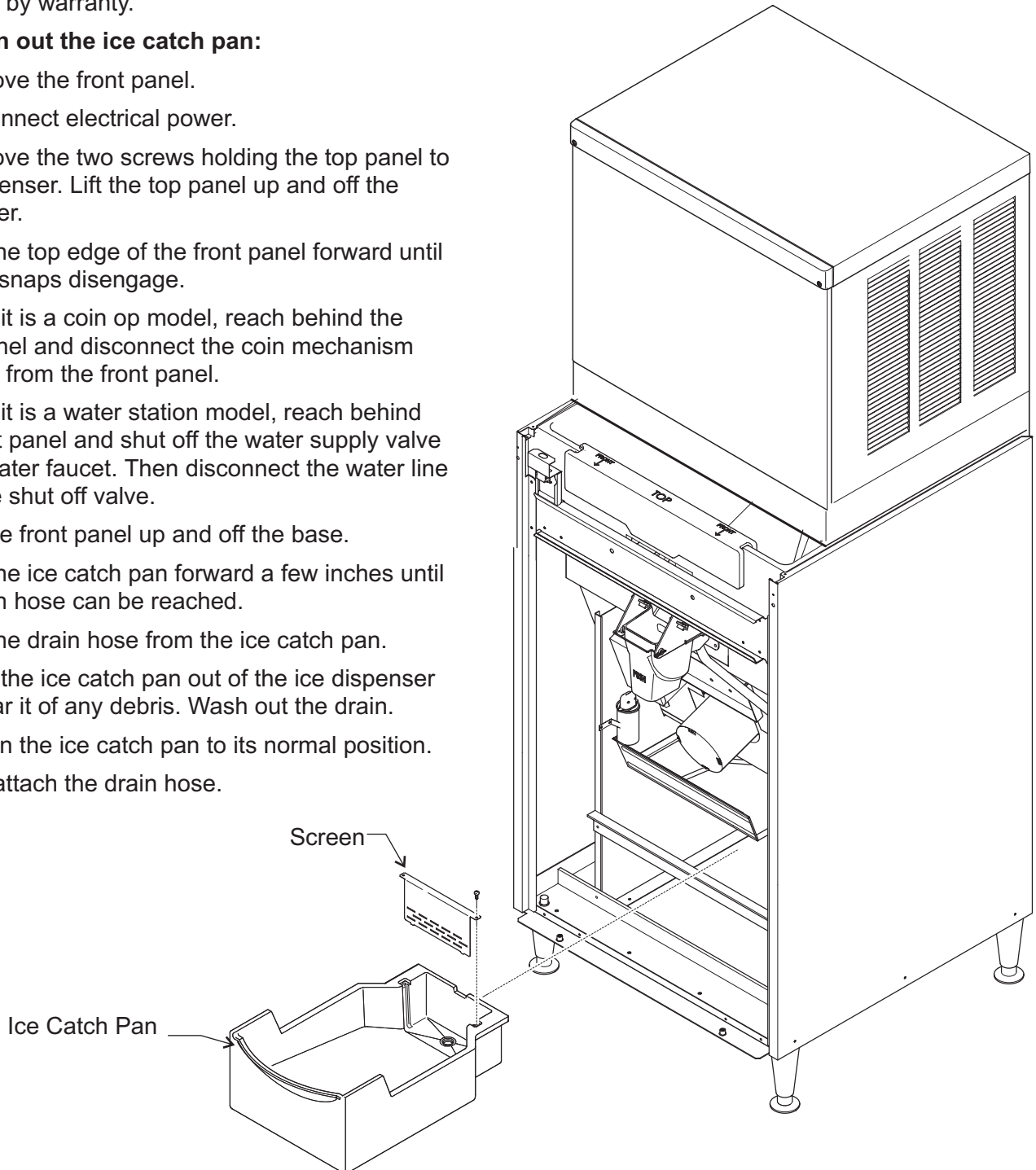

Adjustments

The dispenser is preset at the factory. Adjustments are rarely needed.

Agitation Time Recommendations:

The standard time is 3 seconds on every 6 hours. Adjust to agitate more frequently if the unit is installed in a low temperature environment. However, if the ice being produced by the ice machine is cloudy and crumbles easily, adjust to agitate less frequently.



Agitation Timer, Shown Pre-set to 3 seconds every 6 hours

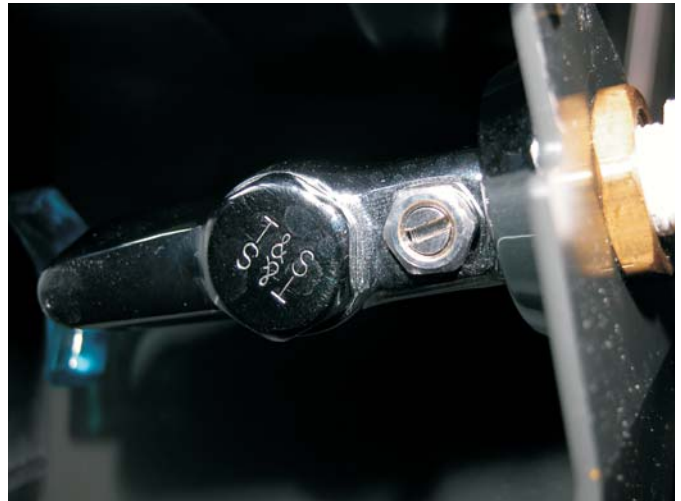

Water Flow Adjustment Screw

HD22 and HD30

Service Diagnosis

Symptom	Probable Cause	Possible Fix	
No ice is dispensed - Basic Model	No power to dispenser	Check for proper power, is dispenser plugged in?	
	No ice	Check ice machine	
	Vend switch does not close		Check vend switch
			Check chute for proper motion
	Chute cannot be pushed back	Check door lock for proper operation	
	Interlock switch open	Check interlock switch, be sure top panel is in place	
	Drive motor windings open	Check drive motor	
Drive gears failed	Check gear reducer		
No ice is dispensed - Coin Op Model	Same as above plus coin switch does not close	Check coin switch	
	Vend timer does not work	Connect power to post 6 of coin mech timer, timer should activate, ready light should be on and pushing the chute should start the gear motor, if not replace the vend timer	
Only dispenses small amount of ice	Sweep arm damaged	Check/replace sweep arm	
No water is dispensed - water station model	Water shut off	Check water supply to unit, check shut off valve inside cabinet	
Water leak	Drain is plugged	Check drain for restriction	
	Ice catch pan has overfilled	Remove excess ice	
	Ice catch pan screen is plugged	Clean screen	
	Seal between ice machine and dispenser is leaking	Remove ice machine and replace gasket tape	
Water drip from spout	Some dripping is normal, but if severe	Check spout drain for restriction	
Coin operated model "Ready" light is on all the time	Resistor is open	Replace resistors (15K, 2 watt in parallel)	

SCOTSMAN ICE SYSTEMS

775 Corporate Woods Parkway,

Vernon Hills, IL 60061

800-726-8762

www.scotsman-ice.com