

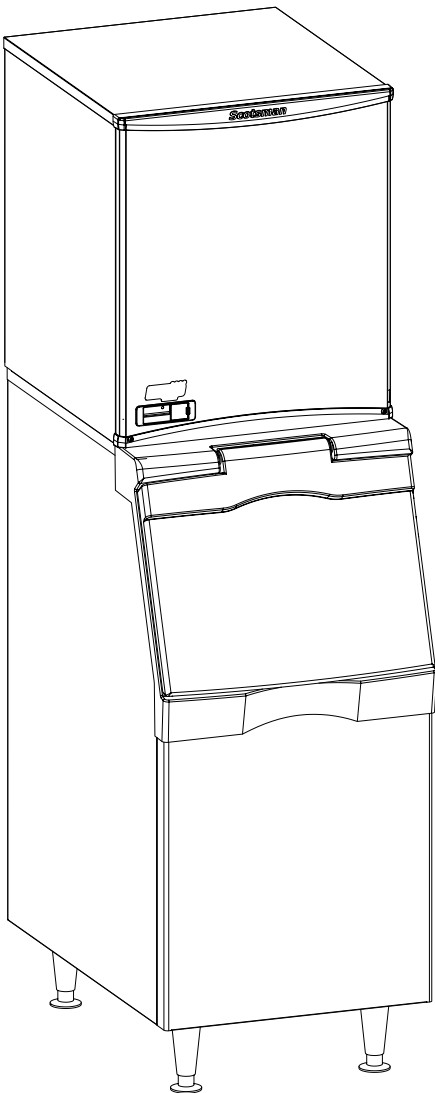

Service Manual for Remote Low Side Modular
Flaked and Nugget Ice Machines
including Prodigy Plus D Series Models
F1222L, F1322L, N0922L and N1322L



N0922L, N1322L, F1222L, F1522L

Remote Low Side Service Manual Includes Prodigy Plus

Introduction

This ice machine is the result of years of experience with flaked and nugget ice machines. The latest in electronics has been coupled with the time tested Scotsman flaked ice system to provide reliable ice making and the features needed by customers.

The features include simple conductivity water level sensing, evaporator clearing at shut down, photo-eye sensing bin control and the ability to add options.

Contents

Installation:	Page 3
Location:	Page 4
Cabinet Layout	Page 5
Unpacking	Page 6
Water	Page 7
Electrical	Page 8
Refrigeration	Page 9
Final Check List.	Page 10
Initial Start Up	Page 11
Controller.	Page 12
AutoAlert and Display Code	Page 13
Component Indicator Lights.	Page 14
Electrical Component Details	Page 15
Sequence of Operation	Page 16
Electrical Sequence with Condensing Unit	Page 17
Water System	Page 18
Remote Refrigeration with Condensing Unit	Page 19
How Ice Is Made	Page 20
Scale removal	Page 21
Check Top Bearing	Page 22
Bearing Service.	Page 23
Options	Page 24
Service Diagnosis	Page 25
Service Diagnosis - Optional Ice Level Controls	Page 26
Repair Procedures: Bearing And Breaker	Page 27
Repair Procedures: The Auger	Page 28
Auger and Evaporator Inspection	Page 29
Repair Procedures: The Water Seal:.	Page 30
Repair Procedures: Replace the Evaporator:	Page 31
Repair Procedures: The gear reducer.	Page 32
Repair Procedures: Thermostatic Expansion Valve	Page 33

N0922L, N1322L, F1222L, F1522L

Remote Low Side Service Manual Includes Prodigy Plus

Installation:

This machine is designed to be used indoors, in a controlled environment. Operation outside the limits listed here will void the warranty.

Air temperature limits

	Minimum	Maximum
Ice maker	50°F.	100°F.

Water temperature limits

	Minimum	Maximum
All models	40°F.	100°F.

Water pressure limits (potable)

	Minimum	Maximum
All models	20 psi	80 psi

Voltage limits

	Minimum	Maximum
115 volt	104	126

Minimum conductivity (RO water)

- 10 microSiemens / CM

Water Quality (ice making circuit)

- Potable

The quality of the water supplied to the ice machine will have an impact on the time between cleanings and ultimately on the life of the product. Water can contain impurities either in suspension or in solution. Suspended solids can be filtered out. In solution or dissolved solids cannot be filtered, they must be diluted or treated. Water filters are recommended to remove suspended solids. Some filters have treatment in them for suspended solids. Check with a water treatment service for a recommendation.

RO water. This machine can be supplied with Reverse Osmosis water, but the water conductivity must be no less than 10 microSiemens/cm.

Potential for Airborne Contamination

Installing an ice machine near a source of yeast or similar material can result in the need for more frequent sanitation cleanings due to the tendency of these materials to contaminate the machine.

Most water filters remove chlorine from the water supply to the machine which contributes to this situation. Testing has shown that using a filter that does not remove chlorine, such as the Scotsman Aqua Patrol, will greatly improve this situation.

Warranty Information

The warranty statement for this product is provided separately from this manual. Refer to it for applicable coverage. In general warranty covers defects in material or workmanship. It does not cover maintenance, corrections to installations, or situations when the machine is operated in circumstances that exceed the limitations printed above.

N0922L, N1322L, F1222L, F1522L

Remote Low Side Service Manual Includes Prodigy Plus

Location:

While the machine will operate satisfactorily within the air and water temperature limits, it will operate more efficiently when those temperatures are nearer the lower limits. Avoid locations that are hot, dusty, greasy or confined.

Options

The standard machine will make ice until ice fills the bin and blocks an infrared light beam inside the bottom of the machine. A field installed kit is available to adjust the ice level lower. That kit number is KVS.

The standard controller has excellent diagnostic capabilities and communicates to the user through the AutoAlert light panel, seen through the front panel. There is a field installed kit that can log data and provide additional information when the front panel is removed. That kit number is KSBU. A similar kit adds network connectivity, and its number is KSB-NU.

Bin compatibility

All models are the same width: 22 inches. All models are the same depth: 24 inches.

Bin & adapter list:

- B322S – no adapter needed
- B330P – Use KBT27
- B530P – Use KBT27
- B530S – Use KBT27
- B842S – Use KBT39
- B948S - Use KBT38 for a single unit
- B948S – Use KBT38-2X for two units side by side

BH1100, BH1300 and BH1600 upright bins include filler panels to accommodate a single 22 inch wide flake or nugget ice machine. No adapter is needed.

Dispenser compatibility

Only nugget ice models may be used with ice dispensers. Flaked ice is not dispensable.

- ID150 – use KBT42 and KDIL-PN-150; includes KVS, KNUGDIV and R629088514
- ID200 – use KBT43 and KNUGDIV and KVS
- ID250 – use KBT43 and KNUGDIV and KVS

See sales literature for other brand model ice and beverage dispenser applications.

Other Bins & Applications:

Note the drop zone and ultrasonic sensor locations in the illustrations on the next page.

Line Set

NRTE45 is a non-precharged tubing kit that contains a 45 foot 3/8" liquid line and a 45 foot 5/8" suction line. Tubes are supplied nitrogen charged and capped.

Scotsman ice systems are designed and manufactured with the highest regard for safety and performance.

Scotsman assumes no liability of responsibility of any kind for products manufactured by Scotsman that have been altered in any way, including the use of any part and/or other components not specifically approved by Scotsman.

Scotsman reserves the right to make design changes and/or improvements at any time. Specifications and design are subject to change without notice.

N0922L, N1322L, F1222L, F1522L

Remote Low Side Service Manual Includes Prodigy Plus Cabinet Layout

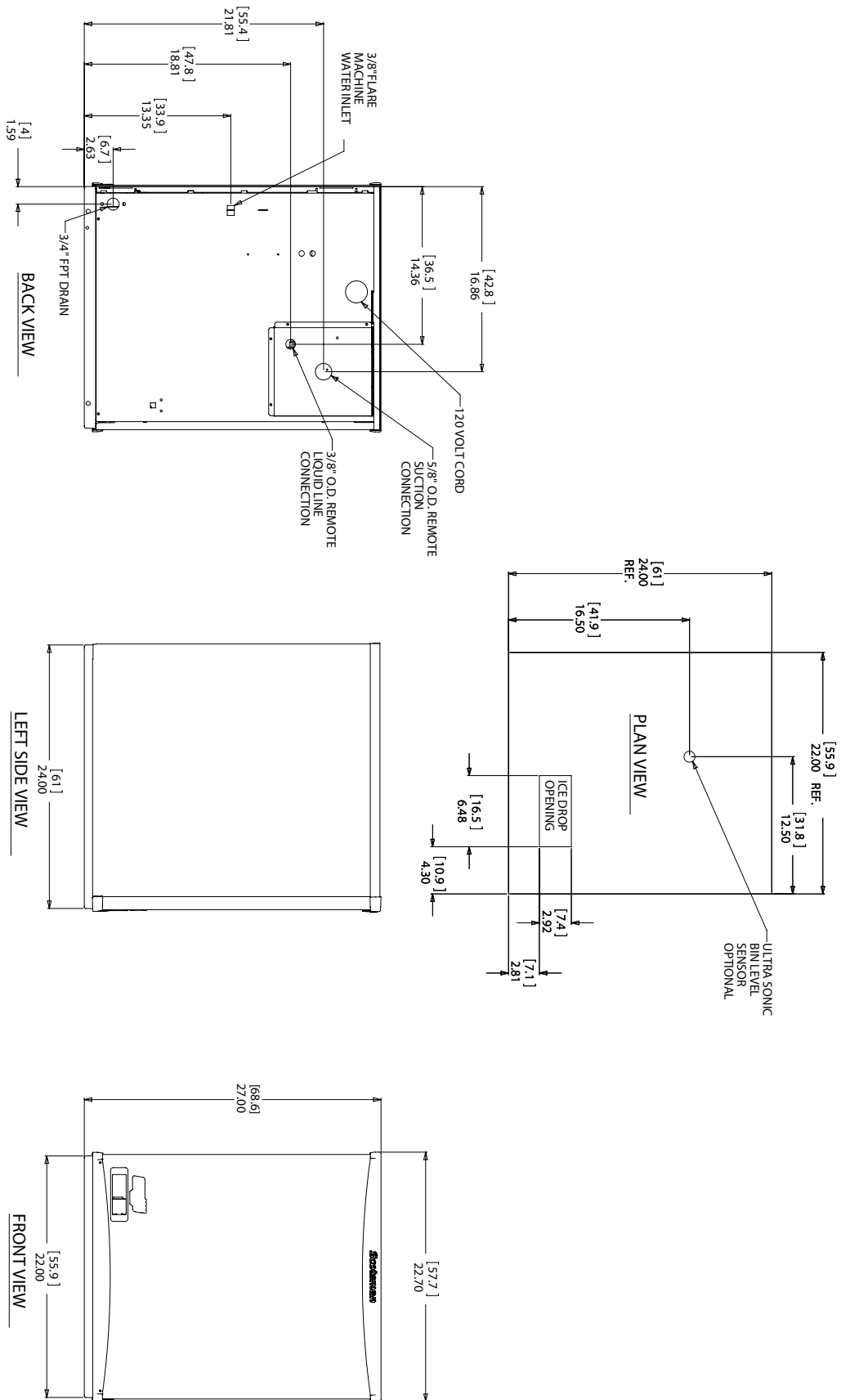

N0922L, N1322L, F1222L, F1522L

Remote Low Side Service Manual Includes Prodigy Plus Unpacking

Remove the carton from the skid. Check for hidden freight damage, notify the carrier immediately if any is found. Retain the carton for the carrier's inspection.

The machine is not bolted to the skid. If strapped remove the strap.

Place on Bin or Dispenser

If reusing an existing bin, be sure that the bin is in good shape and that the gasket tape on the top is not torn up. Water leaks, not covered by warranty, could result from a poor sealing surface. Because this is a remote low side, a new bin is recommended due to the high cost to the user of replacing an old bin when a remote system is on top.

Install the correct adapter, following the directions supplied with that adapter.

Hoist the machine onto the adapter.

Note: The machine is heavy! Use of a mechanical lift is recommended.

Position the machine on the bin or adapter. Secure with straps from the hardware bag packed with the machine, or those supplied with the adapter.

Remove any plastic covering the stainless steel panels.

Remove any packaging, such as tape or foam blocks, that may be near the gear reducer or ice chute.

Level the bin and ice machine front to back and left to right by using the bin leg levelers.

Panel Removal

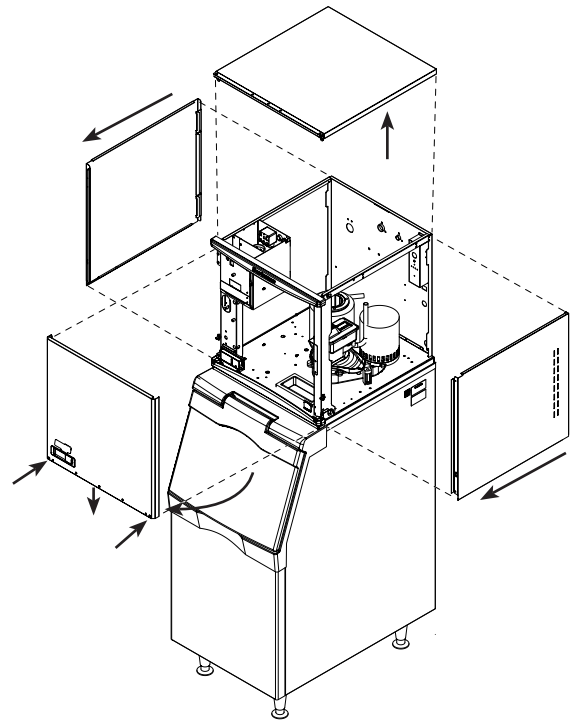

1. Locate and loosen the two screws at the bottom edge of the front panel.
2. Pull the front panel out at the bottom until it clears the bin.
3. Lower the front panel down and off the machine.
4. Remove two screws at the front of the top panel. Lift up the front of the top panel, push the top panel back an inch, then lift to remove.
5. Locate and loosen the screw holding each side panel to the base. Left side panel also has a screw holding it to the control box.
6. Pull the side panel forward to release it from the back panel.

N0922L, N1322L, F1222L, F1522L

Remote Low Side Service Manual Includes Prodigy Plus Water

The water supply for ice making must be cold, potable water. There is a single 3/8" male flare potable water connection on the back panel.

Backflow

The design of the float valve and reservoir prevents potable water backflow by means of a 1" air gap between the reservoir's maximum water level and the float valve water inlet orifice.

Drain

There is one 3/4" FPT condensate drain fitting at the back of the cabinet.

Tubing

Connect the potable water supply to the potable water fitting, 3/8" OD copper tubing or the equivalent is recommended.

Connect the drain tube to the condensate drain fitting. Vent this drain tube.

Do not Tee ice machine drains into the drain tube from the ice storage bin or dispenser. Back ups could contaminate and / or melt the ice in the bin or dispenser.

Follow all local and national codes for tubing, traps and air gaps.

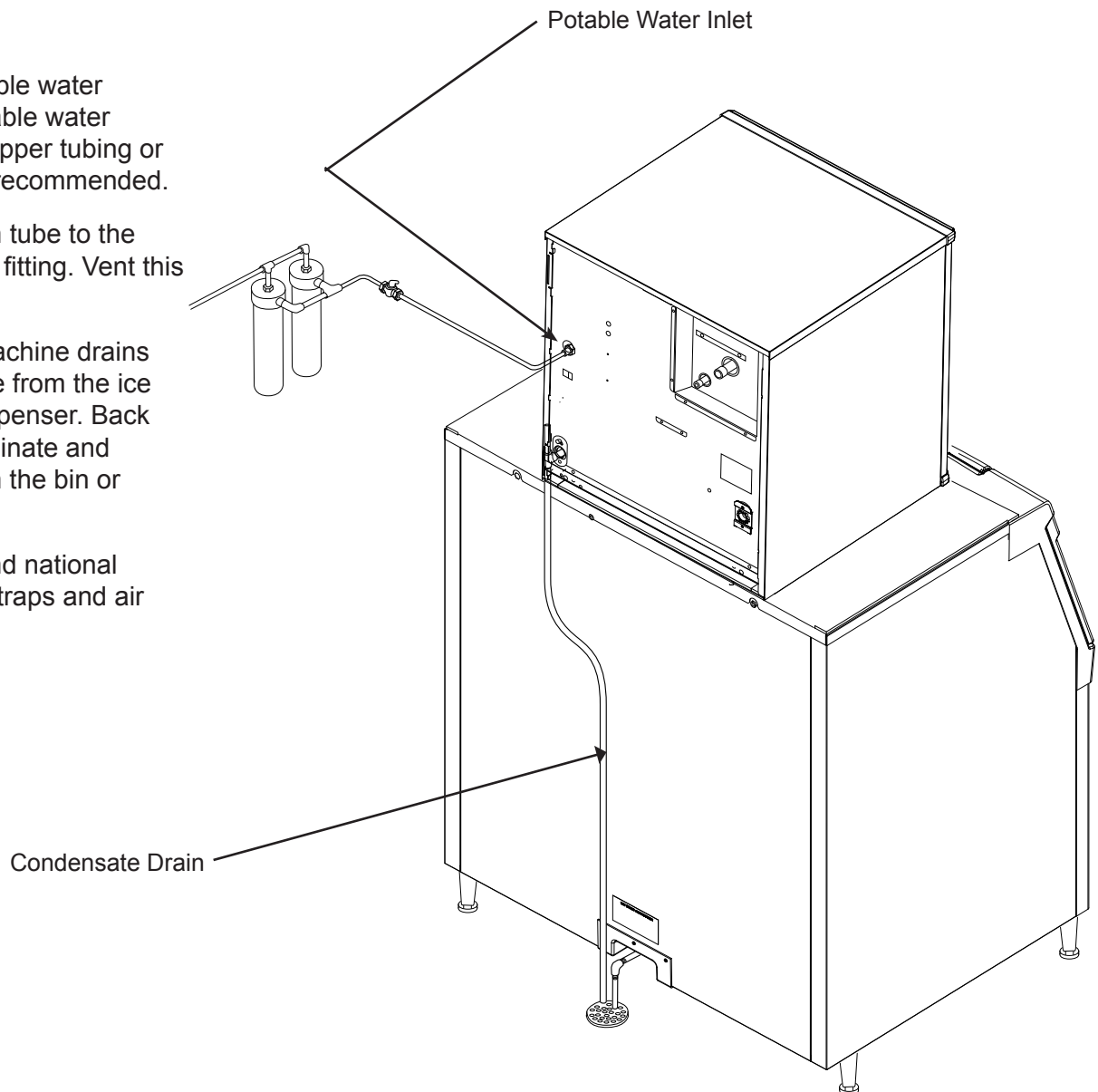

N0922L, N1322L, F1222L, F1522L

Remote Low Side Service Manual Includes Prodigy Plus Electrical

The machine includes a power cord, connect to the proper power supply. A separate circuit is recommended to avoid unintended shut downs.

If a dedicated condensing unit is connected to this machine, it will have a separate power supply.

Do not use an extension cord.

Follow all local and national codes.

Model	Dimensions w" x d" x h"	Voltage Volts/Hz/Phase	Min Circuit Ampacity	Max Fuse Size (cord connected)
All	22 x 24 x 27	115/60/1	5.8	15

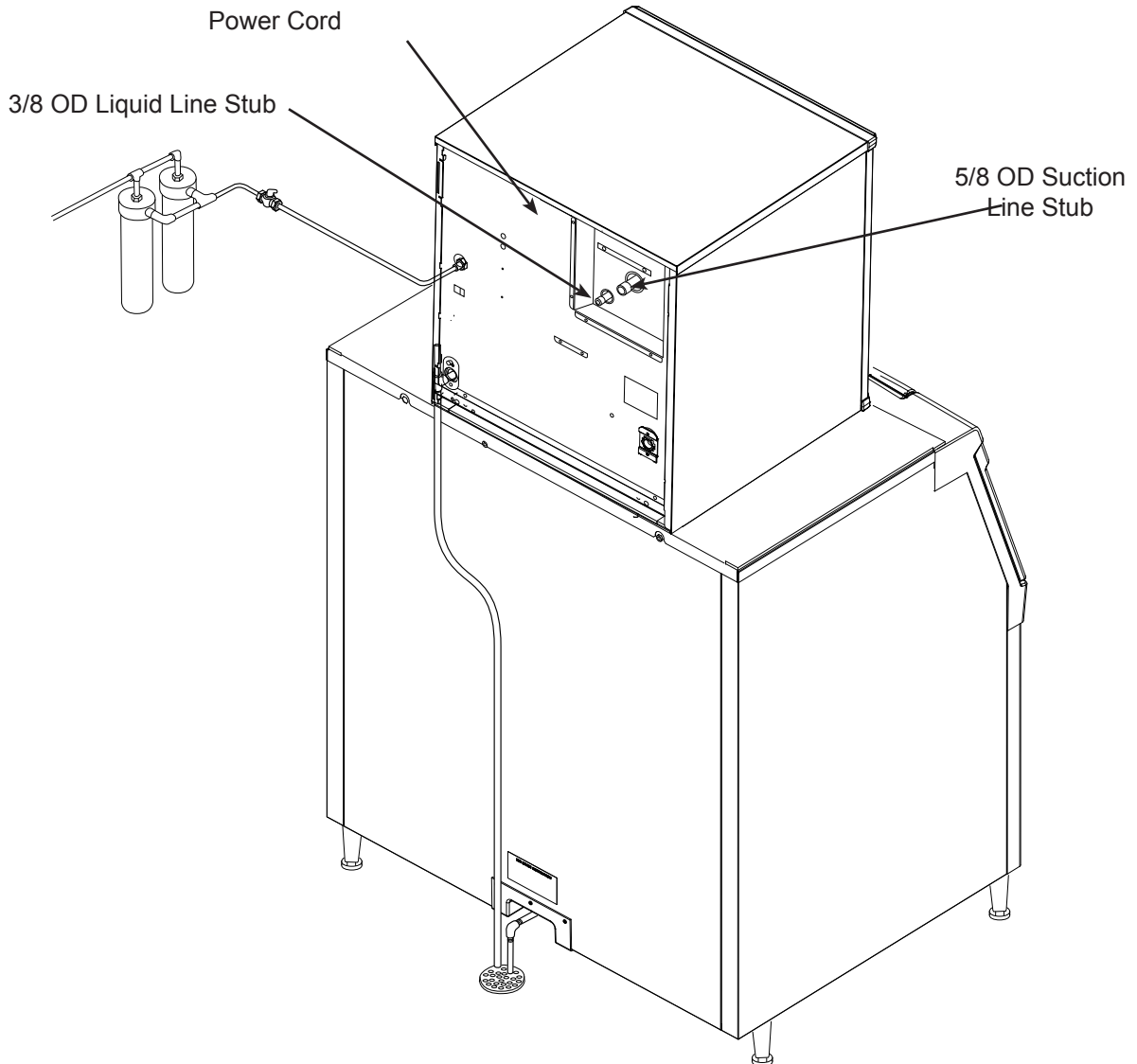

N0922L, N1322L, F1222L, F1522L

Remote Low Side Service Manual Includes Prodigy Plus Refrigeration

BTUH Capacity Requirements

Model	BTUH
N0922L, F1222L	5,000
N1322L, F1522L	7,200

Condensing Units

Model Use Condensing Unit

N0922L or F1222L	NME954-RHS-A/C
N1322L or F1522L	None - rack only

Remote low side models require connection to a dedicated condensing unit or a rack system.

Recommended Tubing from Head to Condensing Unit

- Suction Line: 5/8" OD
- Liquid Line: 3/8" OD

Distance limits:

- Maximum distance between dedicated condensing unit and head: 75 feet.
- Condensing Unit Elevation over Ice Making Section: 35 feet.

Note: Elevations greater than 20 feet require installation of a suction line trap at the 10 foot mark.

Ice Making Section

- Elevation over Condensing Unit: 15 feet.

Line Routing:

- Allowed: One rise after a drop.
- Allowed: One drop after a rise.
- Not Allowed: More than one rise after a drop
- Not Allowed: More than one drop after a rise

Roof Attachment

Install and attach the remote condensing unit to the roof of the building, using the methods and practices of construction that conform to the local building codes, including having a roofing contractor secure the condenser to the roof.

Refrigeration Installation:

Connections

The liquid and suction fittings on the back of the cabinet are stubs. The liquid line size is 3/8" OD. The suction line size is 5/8" OD.

1. Recover holding charge
2. Cut the stubs off.
3. Braze line set tubing to each fitting. Sweep with dry nitrogen while brazing.
4. Dedicated condensing unit: Evacuate complete system to 50 microns.
5. Open the ball valves.

Rack: The skills of a refrigeration technician are required to connect the ice machine to the building's refrigeration system.

Notes:

- R-404A models: 1.5 ounces of R-404A refrigerant is in the system as a holding charge.
- Be sure the liquid connection is NOT in series with another liquid line valve.
- Local Codes must be observed.

Dedicated condensing unit: Add refrigerant charge.

Recommended starting field charge:

- N0922L or F1222L: 8 lb R-404A
- N1322L of F1522L: n/a - rack only

N0922L, N1322L, F1222L, F1522L

Remote Low Side Service Manual Includes Prodigy Plus

Final Check List

After Connections

1. Wash out the bin. If desired, the interior of the bin could be sanitized.
2. Locate the ice scoop (if supplied) and have it available for use when needed.

Final Check List:

1. Is the unit located indoors in a controlled environment?
2. Is the unit located where it can receive adequate cooling air?
3. Has the correct electrical power been supplied to the machine?
4. Have all the water supply connections been made?
5. Have all the drain connections been made?
6. Has the unit been leveled?
7. Have all unpacking materials and tape been removed?
8. Is the correct switch bezel installed in the trim strip?
9. Is the water pressure adequate?
10. Have the drain connections been checked for leaks?
11. Has the bin interior been wiped clean or sanitized?
12. Have any water filter cartridges been replaced?
13. Have all required kits and adapters been properly installed?
14. Has the ice machine been properly connected to the condensing unit or rack?

Control Operation

Use and Operation

Once started, the ice machine will automatically make ice until the bin or dispenser is full of ice.

When ice level drops, the ice machine will resume making ice.

Caution: Do not place anything on top of the ice machine, including the ice scoop. Debris and moisture from objects on top of the machine can work their way into the cabinet and cause serious damage. Damage caused by foreign material is not covered by warranty.

There are four indicator lights at the front of the machine that provide information on the condition of the machine.

Indicator Lights:

- Power
- Status
- Water
- De-scale & Sanitize

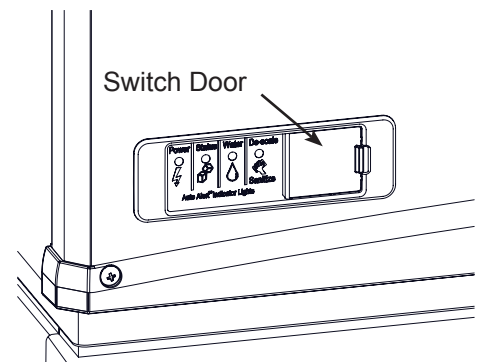

Prodigy Plus: Under the door are two switches – On and Off. To switch the machine OFF, push and release the Off button. The machine will shut off at the end of the next cycle.

To switch the machine ON, push and release the On button. The machine will go through a start up process and then resume ice making.

N0922L, N1322L, F1222L, F1522L

Remote Low Side Service Manual Includes Prodigy Plus Initial Start Up

1. Turn the water supply on.
2. Switch the electrical power on. Confirm voltage is correct for the model.
3. Push and release the On button. The machine will start up in about two minutes.

The liquid line valve will open and liquid refrigerant will flow into the machine. For the units connected to a dedicated condensing unit, the resulting increase in suction pressure will start the condensing unit and the condensing unit will begin discharging warm air from the remote condenser. After about 5 minutes, ice will begin to drop into the bin or dispenser.

4. Check the machine for unusual rattles.
5. Tighten any loose screws, be sure no wires are rubbing moving parts. Check for tubes that rub.
6. Check suction pressure, adjust EPR setting. As shipped the EPR valve should maintain low side pressure at about 36 PSIG + or - 2 PSIG.

Note: Machines will operate and make ice at the factory EPR setting. For optimum performance, adjust the EPR to the settings in the chart below:

Model Number	Scotsman Condensing Unit	Rack
N0922L / F1222L	Full open	30 PSIG
N1322L / F1522L	Not specified	26 PSIG

Superheat will be 12°F, + or - a few degrees.

7. Fill out the warranty registration form and either file it on line or mail it.
8. Notify the user of the maintenance requirements and whom to call for service.

Maintenance

This ice machine needs five types of maintenance:

- Remote condensing units need their condenser coils cleaned regularly.
- All models need scale removed from the water system.
- All models require regular sanitization.

- All models require sensor cleaning.
- All models require a top bearing check.

Maintenance Frequency:

Scale removal. At least twice a year, in some water conditions it might be every 3 months. The yellow De-Scale & Sanitize light will switch on after a set period of time as a reminder. The default time period is 6 months of power up time. There are 4 available time period intervals: 1 year, 0 or disabled, 6 months or 4 months.

Sanitizing: Every time the scale is removed or as often as needed to maintain a sanitary unit.

Sensor Cleaning: Every time the scale is removed.

Top bearing check: At least twice a year or every time the scale is removed.

Maintenance: Remote air cooled condenser

The condenser fins will occasionally need to be cleaned of leaves, grease or other dirt. Check the coil every time the ice machine is cleaned.

Maintenance: Exterior Panels

The front and side panels are durable stainless steel. Fingerprints, dust and grease will require cleaning with a good quality stainless steel cleaner

Note: If using a sanitizer or a cleaner that contains chlorine on the panels, after use be sure to wash the panels with clean water to remove chlorine residue.

Maintenance: Water filters

If the machine has been connected to water filters, check the cartridges for the date they were replaced or for the pressure on the gauge. Change cartridges if they've been installed more than 6 months or if the pressure drops too much during ice making

N0922L, N1322L, F1222L, F1522L
Remote Low Side Service Manual Includes Prodigy Plus
Controller

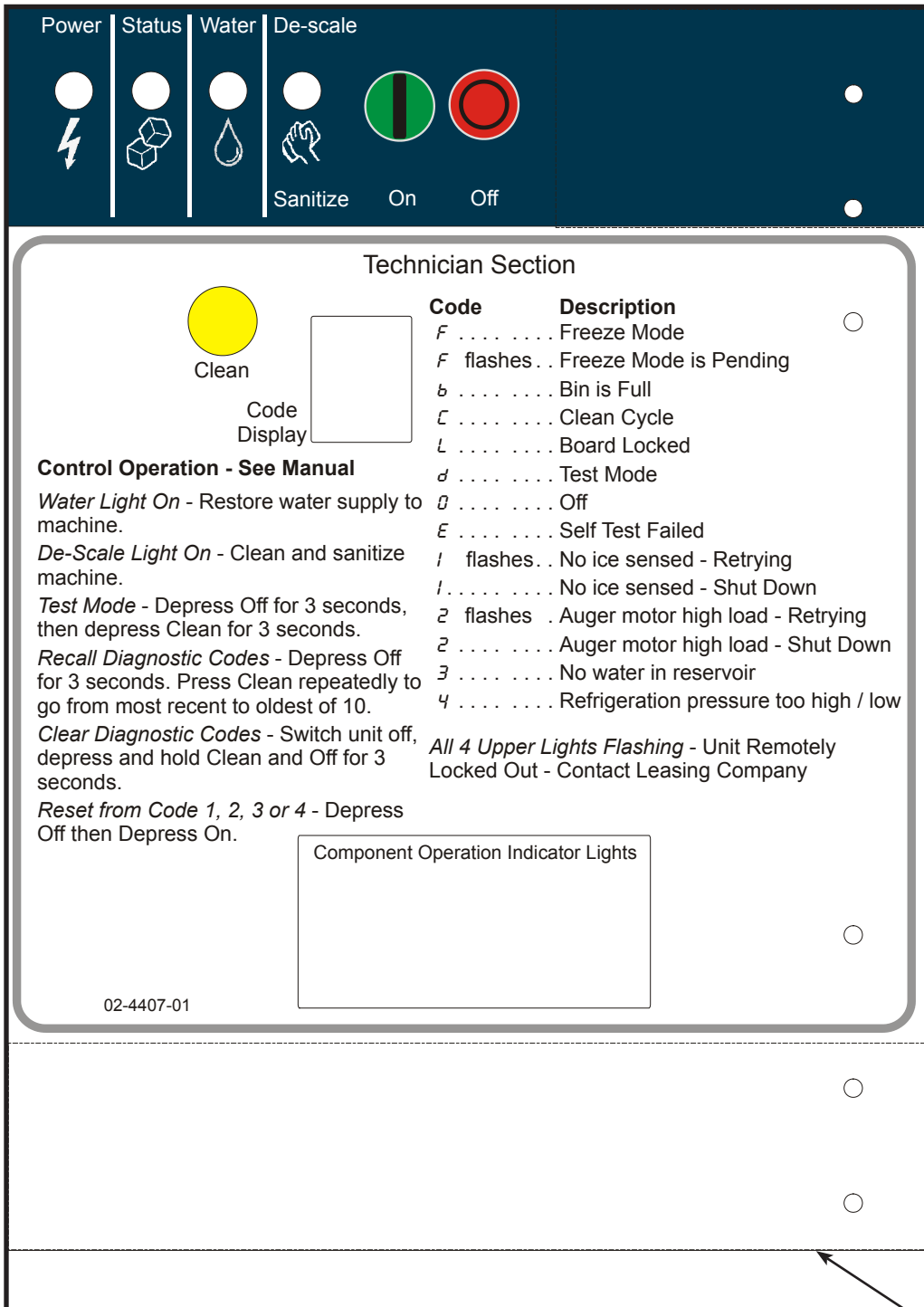

Location of Optional Vari-Smart

Location of Optional Smart-Board

N0922L, N1322L, F1222L, F1522L

Remote Low Side Service Manual Includes Prodigy Plus

AutoAlert and Display Code

The controller uses indicator lights to provide the user with information on Power, Status, Water or Time to Clean. These are known as the AutoAlert panel.

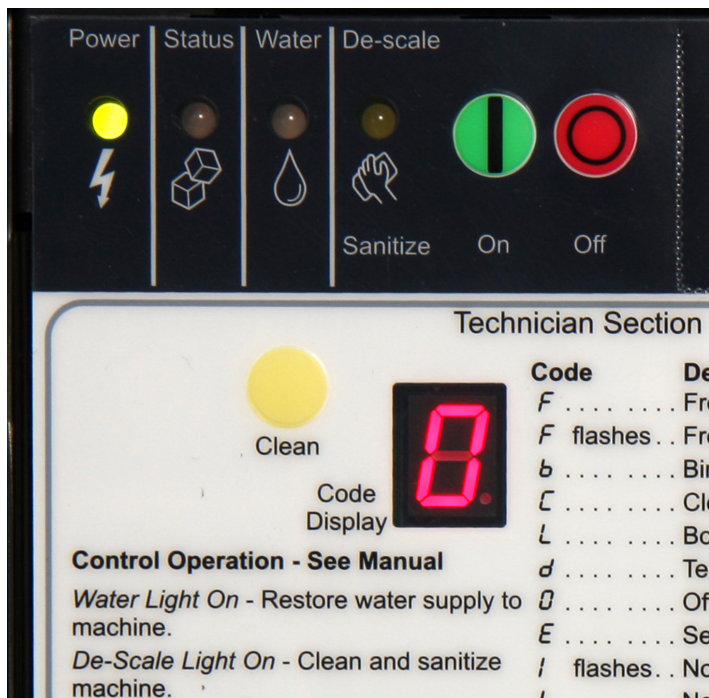

Additionally a 7 segment display is under the front panel. It shows operational status or problem codes.

The Power light is on Green anytime the machine is supplied with electrical power.

Code Description

- F Freeze Mode
- F . flashes . . . Freeze Mode is Pending
- b Bin is Full
- C Clean Cycle
- L Board Locked
- d Test Mode
- O Off
- E Self Test Failed
- 1 . . flashes . . . No ice sensed - Retrying
- 1 No ice sensed - Shut Down
- 2 . . flashes . . . Auger motor high load - Retrying
- 2 Auger motor high load - Shut Down
- 3 No water in reservoir

The Status light is on Green when the machine has been switched to the ice making mode. It will also blink green if the unit has been equipped with an optional Smart-Board AND the Smart-Board has detected potential malfunction.

The Water light will blink Red if the water sensor does not detect water.

The De-Scale / Sanitize light will glow Yellow when the time to clean timer has reached its set time since the last cleaning. It also blinks during the first part of the cleaning mode.

Indicator Lights & Their Meanings				
Light Actions	Power	Status	Water	De-Scale & Sanitize
Steady Green	Normal	Normal	-	-
Blinking Green	Self Test Failure	Switching on or off. When Smart-Board used, machine attention recommended.	-	-
Blinking Red	-	Diagnostic shut down	Lack of water	-
Yellow	-	-	-	Time to descale and sanitize
Blinking Yellow	-	-	-	In Cleaning Mode
Light Off	No power	Switched to Off	Normal	Normal

N0922L, N1322L, F1222L, F1522L

Remote Low Side Service Manual Includes Prodigy Plus Component Indicator Lights

The controller has six lights to indicate component operation:

Bin Eyes Blocked

- This light is ON when the photo-electric ice sensors have been blocked by ice.

Water Present

- This light is ON when the water sensor has water touching it.

Comp

- May light but is not used on this model.

Water Dispense

- Not used on this model, not present on Prodigy Plus

Auger

- This light is ON when the auger motor is operating.

Ice Dispense

- Not used on this model, not present on Prodigy Plus

Control Button Use

Recall diagnostic code:

- Hold off button in for 3 seconds. Release.
- Press and release the Clean button to cycle through each of the last 10 error codes from most recent to oldest.

Clear diagnostic code:

- Hold Clean and Off buttons in for 3 seconds to clear all prior codes.

Reset control:

- Depress and release Off, then depress and release On

Start Test Mode:

- Hold Off button in for 3 seconds. Release.
- Hold Clean button in for 3 seconds. Release.

Lock / Unlock control:

- Hold On button in for 3 seconds, keep holding then press and release Off twice.

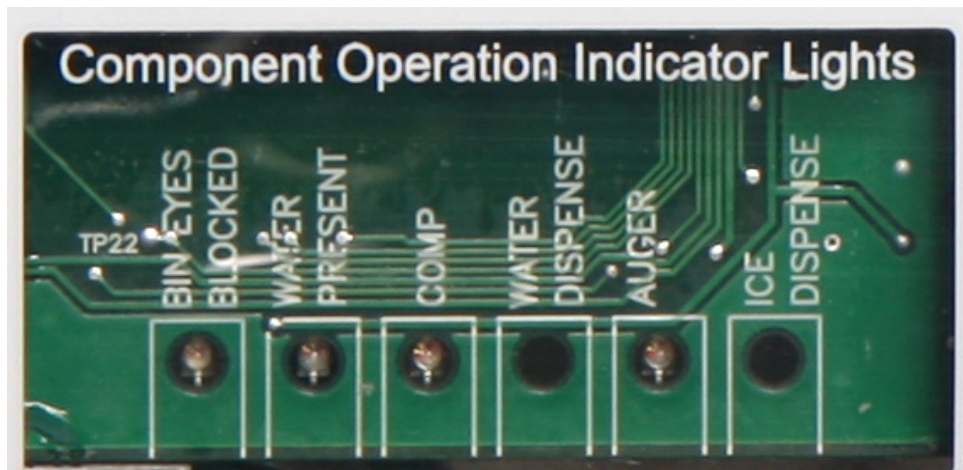

N0922L, N1322L, F1222L, F1522L

Remote Low Side Service Manual Includes Prodigy Plus

Electrical Component Details

Liquid line valve

- Opened by the controller to start ice making.
Closed to shut unit off. Line voltage coil.

Controller

- Senses water, ice making, and auger amps.
Controls liquid line solenoid coil and auger motor.
Indicates status and component operation.

Transformer

- 12 volt secondary, supplies power to controller only. The Power light will be ON when the transformer has provided 12 volts AC to the controller.

Water Level Sensor

- Two probe conductivity sensor. When water touches it the Water Present light will be ON.

Auger Motor

- Four pole, split phase motor that operates the gear reducer. When operating, the Auger indicator light will be ON. The gear reducer lowers the input speed from about 1500 RPM to 11. Auger rotation is CCW when viewed from above.

Photo-electric eyes

- An LED emitter and photo transistor receiver set. Pulsed infrared light is continuously emitted and received to detect ice in the chute.

N0922L, N1322L, F1222L, F1522L

Remote Low Side Service Manual Includes Prodigy Plus

Sequence of Operation

The ice machine's function is to continuously produce ice until the ice level control senses that there is enough ice in the bin or dispenser. There are three systems that operate in close coordination to make ice. They are the electrical system, the water system and the refrigeration system.

The electrical system is the auger drive assembly, liquid line solenoid valve and control system (the auger drive assembly includes the gear reducer, auger and top bearing).

The water system includes the float valve, reservoir, inside of the evaporator and the drain tubing.

The refrigeration system includes the thermostatic expansion valve and outside of the evaporator.

Control System

As noted, the electrical system includes a control system. The control system consists of a controller and sensors. It automatically operates the machine to make ice only when needed. It also monitors the water system and auger drive assembly for proper function.

Sensors are used to monitor the machine. A continuity probe water sensor is located near the float reservoir. The sensor has been in two places, one in a tube from the float tank, and two in the float tank itself. Either allows water to touch the sensor's two stainless steel probes, making a connection between them. That signals to the controller the presence of water. The controller will now allow the machine to make ice unless this sensor's probes have continuity.

A set of photo-electric eyes (infrared emitter and receiver) is located at the base of the ice discharge chute. They are used to sense ice. As ice is made, it falls through the infrared beam from the emitter, causing the receiver to detect it. When ice has filled the bin, the top of the ice pile will continuously stop the beam, breaking the light to the receiver, and that signals to the controller that the bin is full.

Additionally, the control system uses the photo-eyes to confirm ice making. As the machine makes ice, the falling ice causes breaks in the infrared beam. In operation, the first 6 minutes of ice making are ignored to give the machine time to start producing ice. After that, the controller will look for a minimum of one beam-break in 10 minutes. If this is not achieved, the control will shut the machine down for 10 minutes and add the incident to a strike counter. During the wait period, a 1 will be flashing in the code display.

After the 10 minute wait, the machine will restart. If no ice is sensed three times in a row, the machine will shut down on a no ice error and must be manually reset. The 1 in the code display will change from flashing to continuous.

If ice is detected within 10 minutes after any restart, the strike counter will be reset to zero, and the code display will show F, for freeze mode.

The auger drive motor amperage is monitored by the controller. If the auger motor is overloaded and is drawing too many amps, the controller will shut the machine off, and a 2 will be flashing in the code display. The controller will attempt a restart of the auger motor in 4 minutes. If during the first 60 seconds after restart the auger motor current stays within limits, the compressor is restarted and the machine returns to normal operation. If the auger motor's current is excessive within 60 seconds after the restart, the process will be repeated once more. If during that try the current is still excessive the machine shuts down and must be manually reset. The 2 in the code display will change from flashing to continuous.

Water System

The water level in the evaporator is maintained by a float valve in a separate reservoir. As ice is made, and water is used, the water level in the reservoir drops, opening the float valve. The open valve adds water to the reservoir to resupply it.

N0922L, N1322L, F1222L, F1522L

Remote Low Side Service Manual Includes Prodigy Plus Electrical Sequence with Condensing Unit

Pushing and releasing the On button starts the machine. The sequence of operation begins with water. Water must be sensed or the controller will not start the ice making process. If there is no water, a 3 will show in the code display. If there is water, and there is nothing blocking the infrared beam of the ice sensors, the controller will start the machine. A flashing F will show in the code display while the auger drive motor starts up. When it has started, the liquid line valve will open and the flashing F will change to a continuous F.

An open liquid line valve allows refrigerant to flow from the condensing unit into the evaporator and suction line. That raises the suction pressure at the condensing unit, causing the low pressure switch to close, starting the compressor.

Ice making continues until the ice level control senses a full bin, at that time the compressor is shut off, and the auger motor continues to operate for a short time to clear the evaporator of any left over ice. A b will show in the code display.

N0922L, N1322L, F1222L, F1522L

Remote Low Side Service Manual Includes Prodigy Plus Water System

Water enters the machine through the 3/8" male flare at the rear of the cabinet, goes to the water reservoir which it enters through the float valve.

The float valve maintains a constant level of water in the reservoir and evaporator, as water flows out the bottom of the reservoir tank to fill the evaporator.

Reservoir overflow or evaporator condensation is routed to the drain. Water cooled models have a separate water circuit for the cooling water: it enters the fitting at the rear, goes to the water regulating valve, then to the water cooled condenser and down the drain.

Water Level: The correct water level should be checked when the machine is making ice. Check

the water level in the reservoir and compare it to the horizontal line molded into the side of the reservoir.

The correct level should be between 1/8" above and 1/4" below the line. If needed, bend the float arm up or down to adjust the water level.

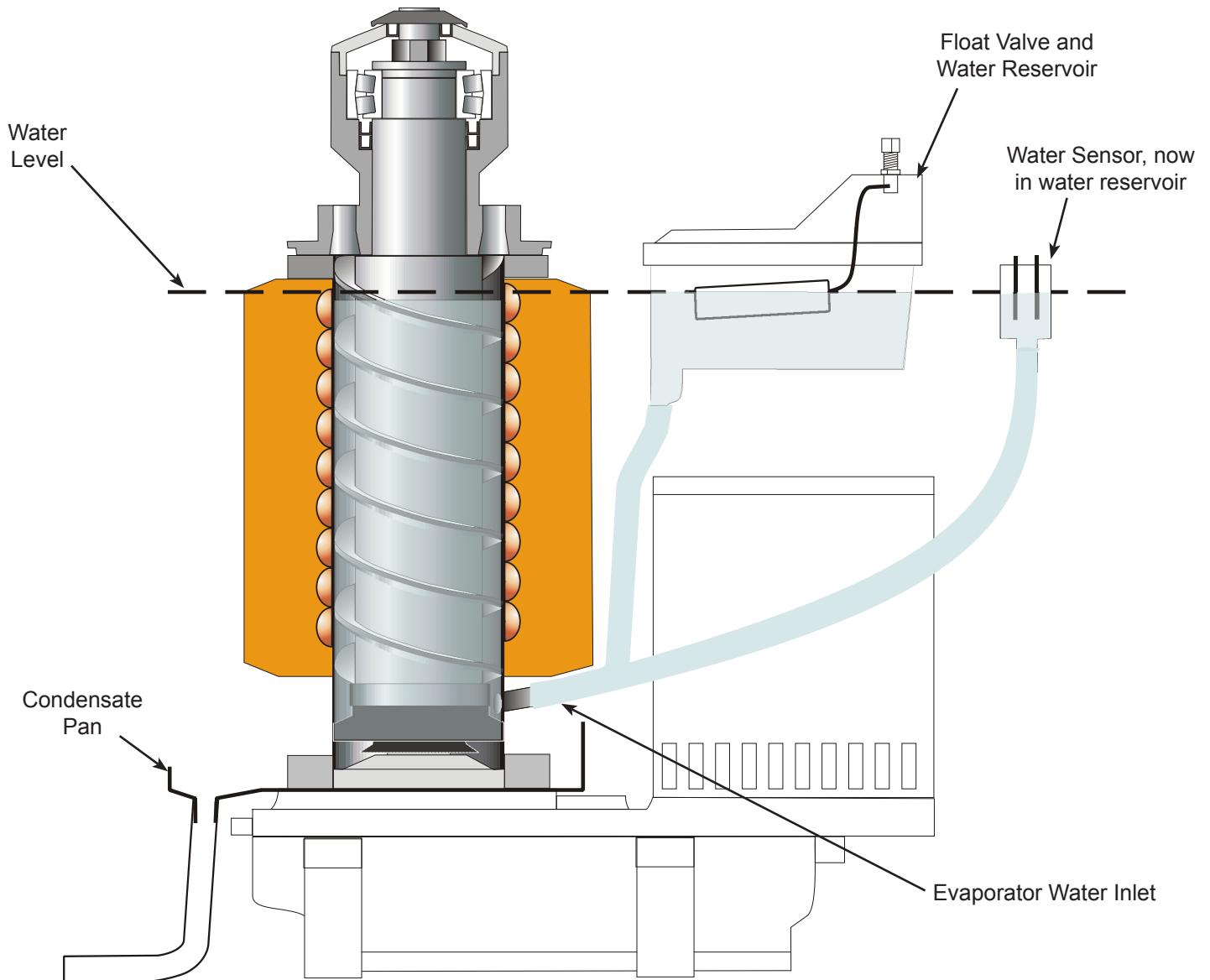

Water Schematic

N0922L, N1322L, F1222L, F1522L

Remote Low Side Service Manual Includes Prodigy Plus Remote Refrigeration with Condensing Unit

A condensing unit's compressor concentrates the heat from ice making into high pressure, hot discharge gas. The high pressure forces the gas to the condenser. At the remote condenser, the discharge gas will either enter the coils or bypass them through the headmaster. The head master maintains a minimum discharge pressure to keep flash gas out of the liquid line.

From the condenser, refrigerant flows to the receiver. It can be either liquid or gas, depending upon the modulation of the head master.

From the receiver, liquid refrigerant flows to the ice making head's thermostatic expansion valve. At the expansion valve, liquid refrigerant passes from a high pressure zone to one of relatively low pressure, and in the low pressure zone it evaporates, absorbing heat.

From the evaporator, the refrigerant, carrying the heat from ice making, flows back to the compressor through the suction line, and the cycle continues.

When enough ice has been made, the control system closes the liquid line solenoid valve and the condensing unit, when used, pumps down, forcing refrigerant out of the low side until its pump down pressure switch stops the compressor.

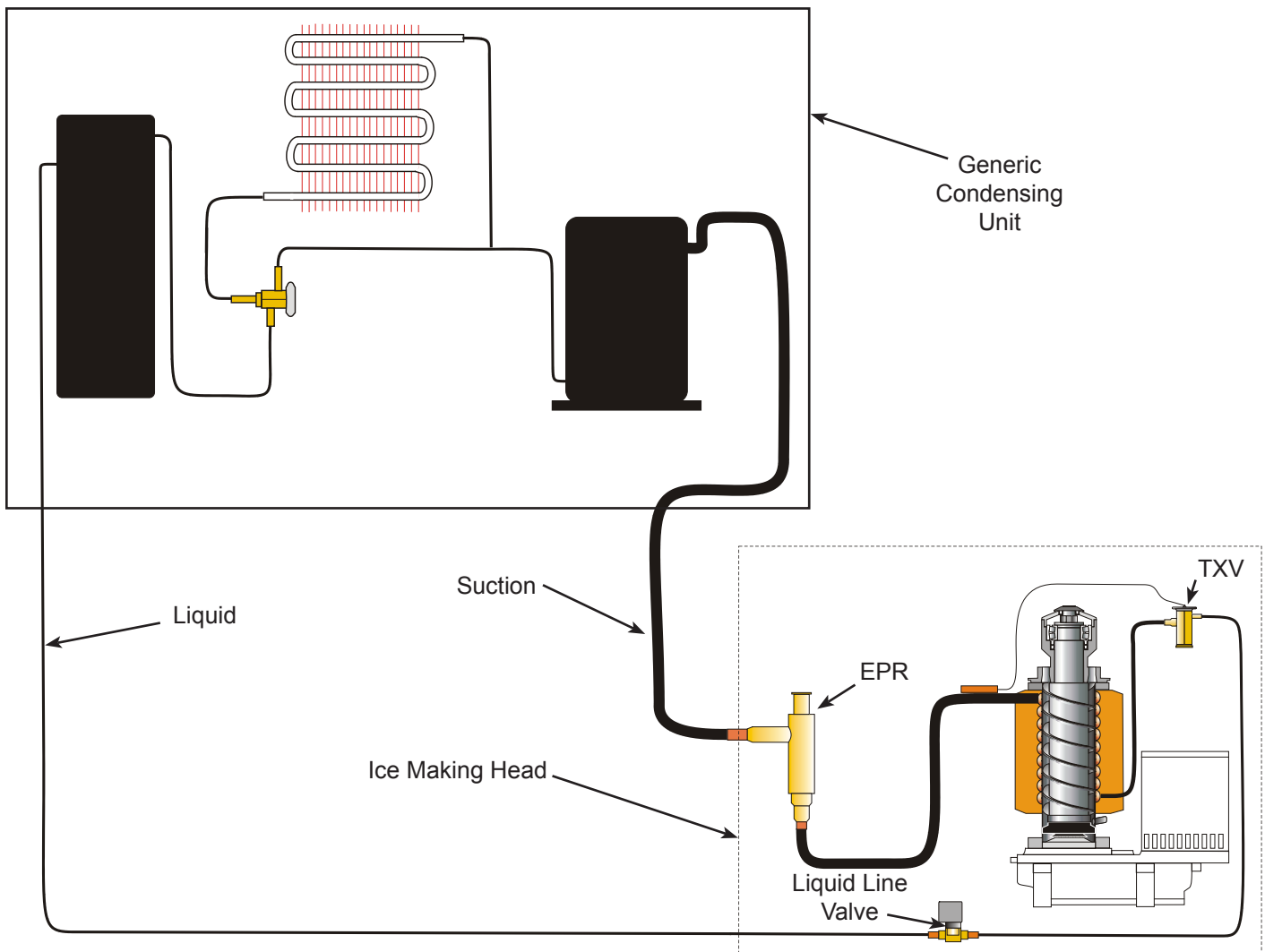

Remote Low Side Refrigeration Schematic

N0922L, N1322L, F1222L, F1522L

Remote Low Side Service Manual Includes Prodigy Plus How Ice Is Made

Refrigeration effect is applied to the water between the auger and the evaporator. When that water's temperature drops to its freezing point, ice crystals form throughout it. A continually rotating auger moves the ice up the evaporator tube. At this point the ice is a soft ribbon that fills the space between the auger and evaporator.

At the top of the evaporator tube, ice emerges from the water and is forced or extruded through relatively small openings. This has the effect of squeezing out excess water and compressing the ice together into a useable form.

Ice flowing up from the openings is forced to one side, breaking it into smaller lengths. An ice sweep moves them to the chute.

Flaked ice machines have 6 oblong and curved slots that ice flows from, and they produce a softer, wetter ice form.

Nugget ice machines have 16 round holes that form the nuggets, which is more heavily compressed and contains less water than freshly made flaked ice.

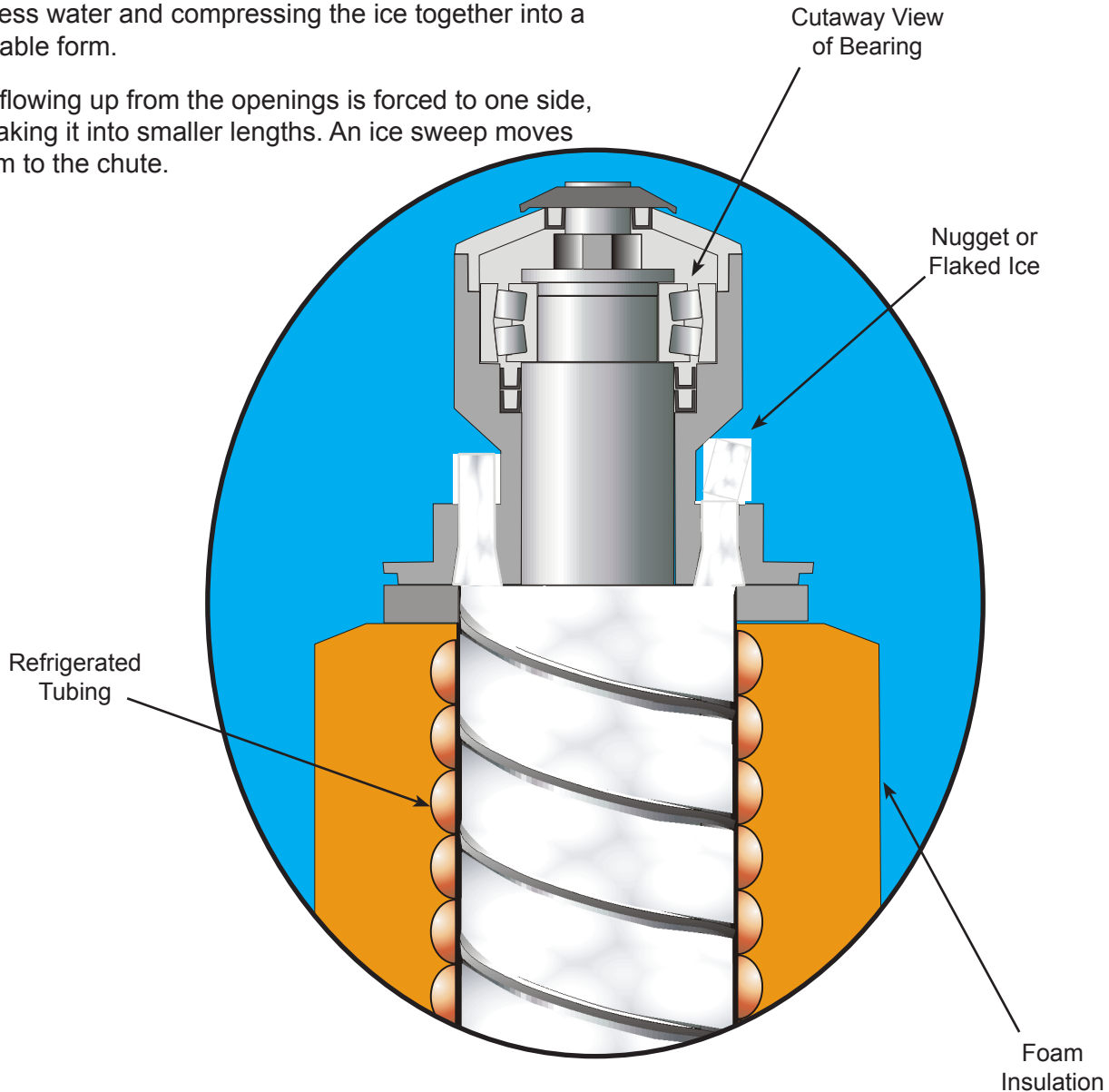

N0922L, N1322L, F1222L, F1522L

Remote Low Side Service Manual Includes Prodigy Plus Scale removal

Note: Following this procedure will reset the de-scale and sanitize light.

1. Remove front panel.
2. Push and release the Off button.
3. Remove ice from bin or dispenser.
4. Turn the water supply to the ice machine OFF.
5. Drain the water and evaporator by disconnecting the leg of the hose connected to the water sensor and draining it into the bin. Return the hose to its original position.
6. Remove the water reservoir cover.
7. Mix a solution of 8 ounces of Scotsman Clear One Scale Remover and 3 quarts of 95-115 degree F. potable water.

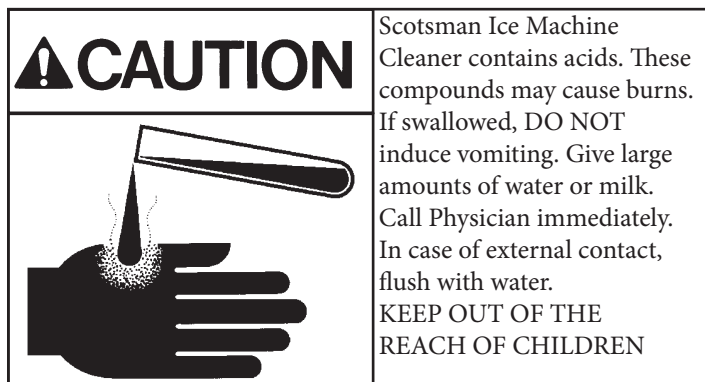

8. Pour the scale remover solution into the reservoir. Use a small cup for pouring.
9. Push and release the Clean button: the auger drive motor and light are on, C is displayed and the De-scale light blinks. After 20 minutes the compressor will start.
10. Operate the machine and pour the scale remover into the reservoir until it is all gone. Keep the reservoir full. When all the scale remover solution has been used, turn the water supply back on. After 20 minutes of ice making the compressor and auger motor will shut off.
11. Turn the water supply to the ice machine OFF
12. Drain the water reservoir and evaporator by disconnecting the leg of the hose connected to the water sensor and draining it into the bin or a bucket. Return the hose to its original position.

Discard or melt all ice made during the previous step.

13. To sanitize the water system, mix a locally approved sanitizing solution. An example of a sanitizing solution is mixing one ounce of liquid household bleach and two gallons of 95 – 115 degree F. water.
14. Pour the sanitizing solution into the reservoir.
15. Push and release the On button.
16. Switch the water supply to the ice machine on.
17. Operate the machine for 20 minutes.
18. Push and release the Off button.
19. Wash the reservoir cover in the remaining sanitizing solution.
20. Return the reservoir cover to its normal position.
21. Melt or discard all ice made during the sanitizing process.
22. Wash the inside of the ice storage bin with the sanitizing solution.
23. Push and release the On button.
24. Return the front panel to its original position and secure with the original screws.

N0922L, N1322L, F1222L, F1522L

Remote Low Side Service Manual Includes Prodigy Plus

Check Top Bearing

This task should only be done by a qualified service technician

The bearing in the breaker should be checked at least two times per year.

Check the bearing by:

1. Removing the bail clamp and ice chute cover

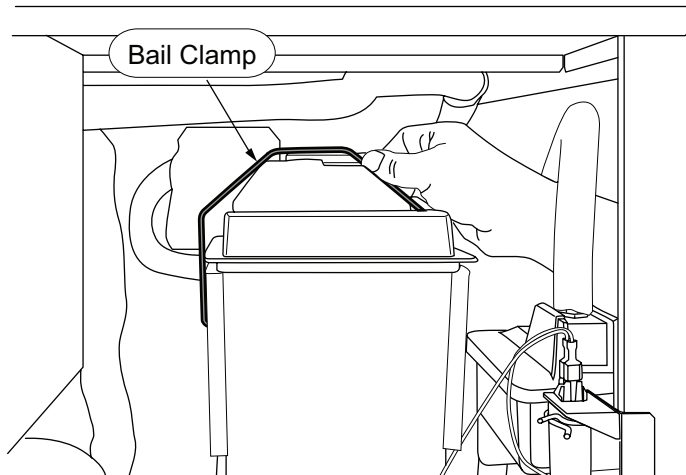

2. Unscrewing the ice sweep

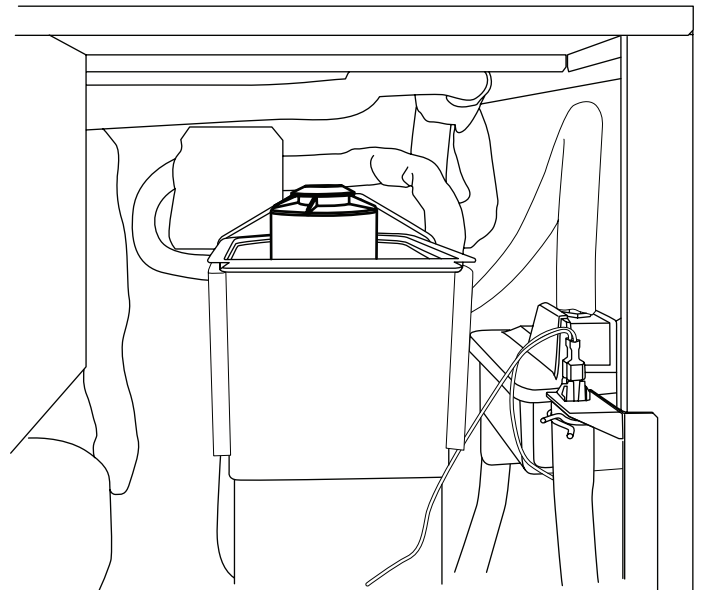
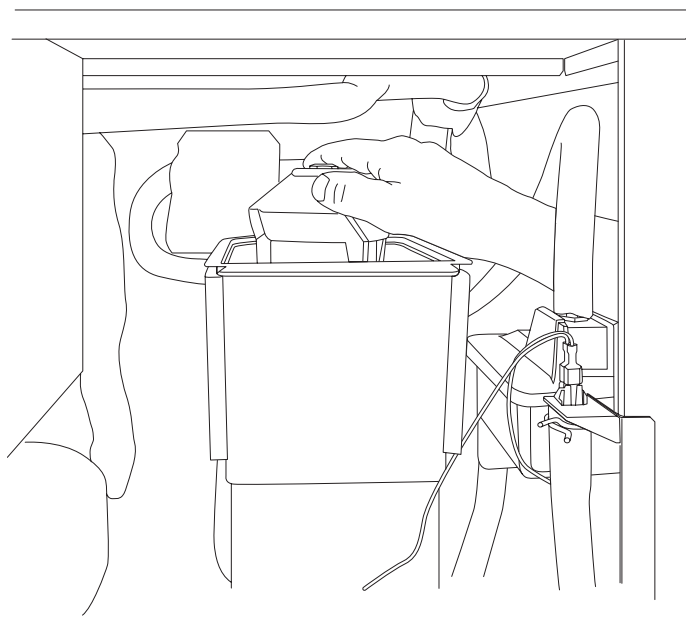

3. Removing the water shed & unscrewing the breaker cover (left hand threads).

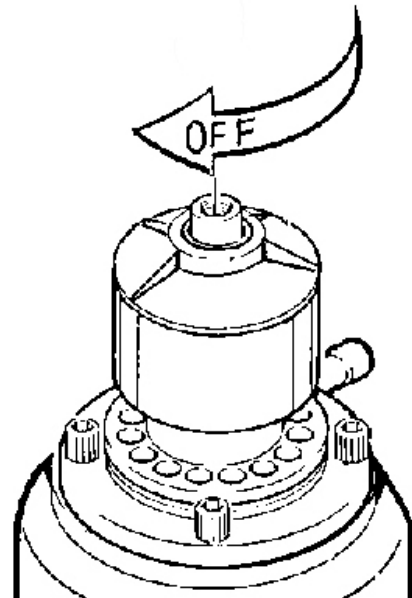

4. Inspect the top of the bearing. When new the grease is white, over time some gray will appear over the rollers, that is normal. Add grease to replace gray grease or if gaps between rollers are visible. If grease is watery, all gray or rust is visible, have the bearing replaced. See the next page for more information.

Note: When checking the top bearing, always inspect the drip pan for water seal leaks. If water is present in the drip pan, service the water seal and check the gear reducer's lubricant. See the next page.

N0922L, N1322L, F1222L, F1522L

Remote Low Side Service Manual Includes Prodigy Plus Bearing Service

This task should only be done by a qualified service technician

If the bearing only needs grease, or to confirm the quality of the grease low in the bearing, inject grease into the lower part of the bearing using Scotsman

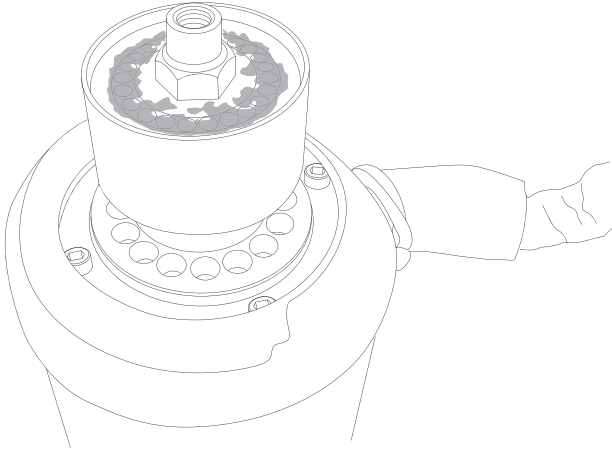

grease needle pn 02-3559-01 and Scotsman bearing grease cartridge, pn A36808-001. Be sure to inject grease evenly and thoroughly.

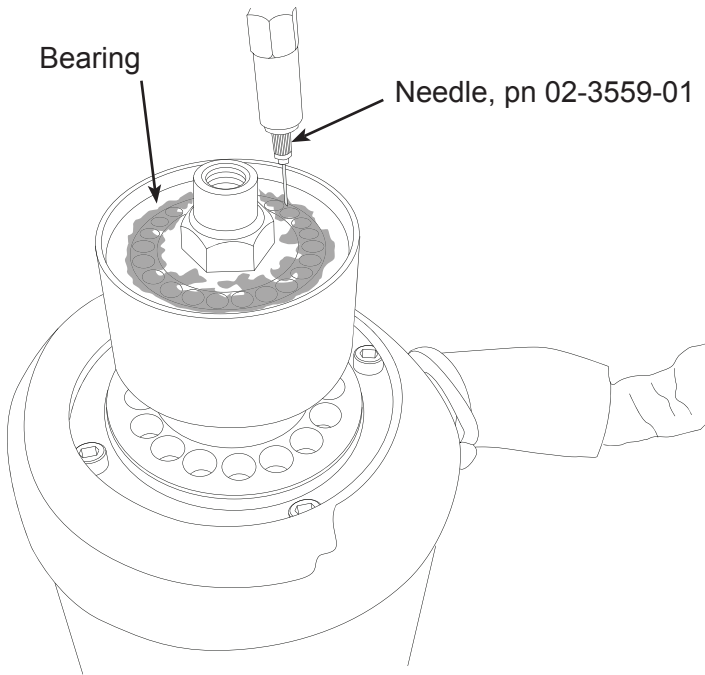

If the grease is uniformly white, no further action is needed. If very gray, rusty, wet or has any embedded metal, have the bearing replaced.

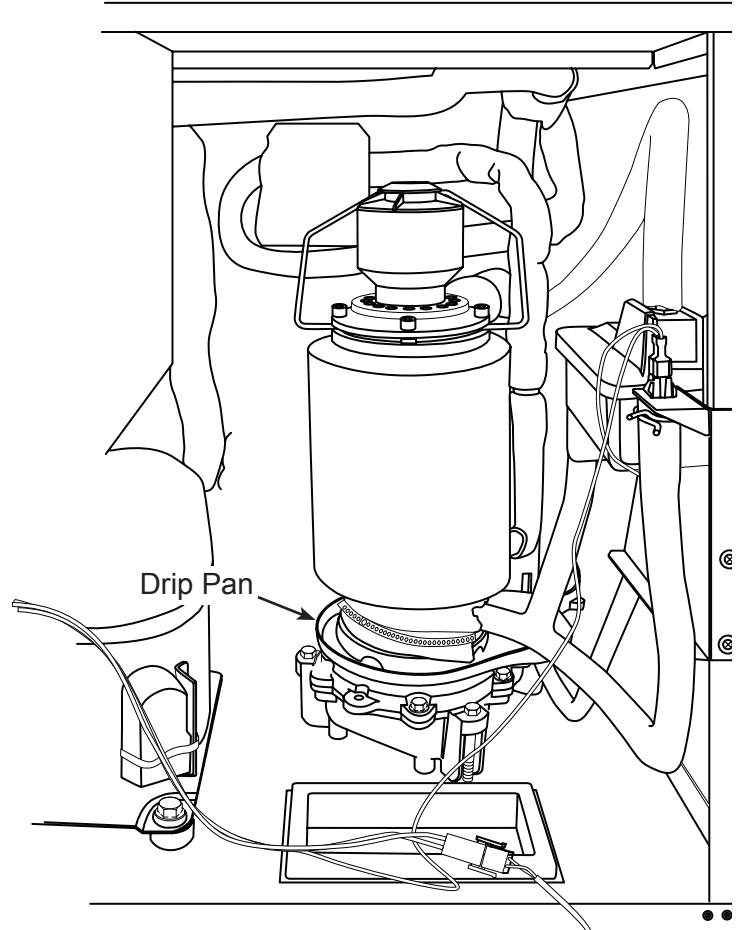

Check Drip Pan For Water

Change De-Scale Notification Interval

This feature is accessible only from standby (Status Light Off).

1. Press and hold Clean button for 3 seconds.

Starts the Time to Clean Adjustment State and displays the current time to clean setting.

2. Press the clean button repeatedly to cycle through the 4 possible settings:

- 1 year (8760 hours)
- 0 (disabled)
- 4 months (2920 hrs)
- 6 months (4380 hours) (default)

N0922L, N1322L, F1222L, F1522L

Remote Low Side Service Manual Includes Prodigy Plus Options

Vari-Smart

Optional adjustable ice level control (KVS)



When this option is present there is an adjustment post and an additional indicator light to the right of the four indicator lights mentioned earlier. The ultrasonic ice level control allows the user to control the point that the ice machine will stop making ice before the bin or dispenser is full. Reasons for this include:

- Seasonal changes in ice used
- Planning to sanitize the bin
- Faster turnover for fresher ice
- Certain dispenser applications where maximum ice level is not desired

There are several positions the ice level can be set to, including Off (knob and label indicators lined up), where it fills the bin until the standard bin control shuts the machine off. See the kit's instructions for complete details.

Rotate the adjustment post to the desired ice level. The machine will fill up to that level and when it shuts off the indicator light next to the adjustment post will be On.

Note: The maximum fill position is when the arrow on the knob points to the arrow on the label

Dispenser applications -

Nugget ice only:

Set the adjustment knob to either the first or second position CW after the maximum fill position.



Another bin control method available on these machines is a bin thermostat.

Type: Opens on temperature fall.

Connects: To blue wires to controller, in place of the jumper connecting the blue wires between terminals 5 and 6.

Use: In certain ice dispenser kits or whenever a permanently lowered ice level is desired and a KVS is not suitable.

Mounts: To the control box support strut.

Result when open: Machine shuts down, b in code display.

Results when closed: Machine makes ice until either the circuit opens or the photo-eyes are blocked by ice.

Circuit voltage type: Low

N0922L, N1322L, F1222L, F1522L

Remote Low Side Service Manual Includes Prodigy Plus Service Diagnosis

Symptom	Probable Cause	Possible Correction	
No ice	No power	Check that ice machine and condensing unit, if used, both have power. If power light is out, check transformer.	
	Code 3: No water	Restore water	
	Status light is off	Push and release ON switch	
	Code 1: No ice sensed		Check for ice flow down chute. if very slow or no ice being made, check water inlet tubing for restriction; check for condensing unit or refrigeration system failure
			Check auger motor for power, if no power, check controller component indicator light. If there is power to the motor, check motor windings
	Code 2: Auger motor draws too many amps, controller shuts unit off.		Check that liquid line valve shuts off tightly
			Check for damage to gear reducer or auger bearings.
	Bin Eyes Blocked light is On		Ice is in the chute.
			No ice in the chute. Check position of sensors, check sensors for scale build up
	Everything is in operation, but no refrigeration effect		Check liquid line valve
Check condensing unit			
Check TXV			
Check refrigerant charge			
Low ice making capacity	Scale build up	Remove scale from evaporator and water system	
	Restricted water supply to evaporator	Squeeze hose, if bubbles appear revise hose and reservoir	
	Suction tubing kinked	Check suction tubing	
	Expansion valve superheat incorrect	Check superheat	

N0922L, N1322L, F1222L, F1522L

Remote Low Side Service Manual Includes Prodigy Plus Service Diagnosis - Optional Ice Level Controls

Vari-Smart (KVS)

Symptom	Probable Cause	Possible Correction
No ice, bin full light is ON	Adjustment knob set too low	Rotate knob to first position, knob's arrow pointing to the left of the L in Lower (on the label)
	Obstruction beneath sensor	Check for and clear any item that might be below the sensor
	Sensor recessed	Check sensor, sensor must be flush in its holder and not recessed.
No ice, b in code display, no bin thermostat	Chute thermostat is open	Check chute thermostat
No ice, power light on, bin full light is OFF	Photo-eye in chute blocked	Check controller display code. If a b, check for blockage or scale build up on photo eyes in chute
		Check for photo eye failure
	Optional Smart-Board is controlling ice level	Check Smart-Board settings.
Ice level too high	Adjustment knob set to maximum fill	Check if knob's arrow points to label arrow.
	Sensor wire disconnected	Check for proper connection of sensor wire to VS control board

Bin Thermostat

Symptom	Probable Cause	Possible Correction
No ice, b in code display	Bin stat is open	Check for ice on bin thermostat capillary tube
		Check for cold ambient in bin
		Check continuity of bin thermostat when capillary tube is warm, replaced if does not close
Unit overfills, shuts off on photo-eyes	Bin stat is stuck closed	Check position of bin thermostat capillary tube.
		Check continuity of bin thermostat when ice is on the capillary tube, replaced if does not open

N0922L, N1322L, F1222L, F1522L

Remote Low Side Service Manual Includes Prodigy Plus

Repair Procedures: Bearing And Breaker

Note: Removal of the auger, water seal, evaporator and gear reducer w/ motor must begin at the top of the assembly.

Note: Seals must be pressed in with a tool, they will not install by hand. A 2" PVC coupling works well as an insertion tool. Seals install open side up.

To Remove the Breaker Bearing Assembly:

1. Remove panels and disconnect electrical power.

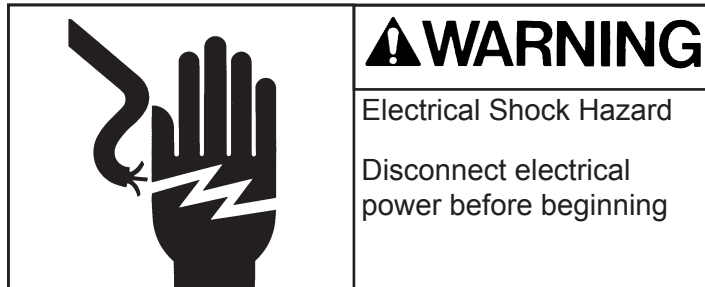

2. Push back bail clamp and remove ice chute cover.

3. Unscrew and remove ice sweep.

4. Lift up and remove ice chute.

5. The breaker may be removed from the auger and evaporator without disturbing the auger.

- a. Unscrew breaker cover from breaker (left hand threads)
- b. Unscrew auger stud from top of auger.
- c. Unscrew 4 allen head cap screws holding breaker to evaporator.
- d. Lift up, and remove breaker/bearing assembly from auger & evaporator.

6. Service the bearing. Check for rust, rough spots and damage.

- a. The bearing is pressed into the breaker, to remove the bearing and replace it an arbor press is needed.
- b. Replace lower seals before installing new bearing in breaker.

Lip seals must be lubricated with food grade grease prior to assembly.

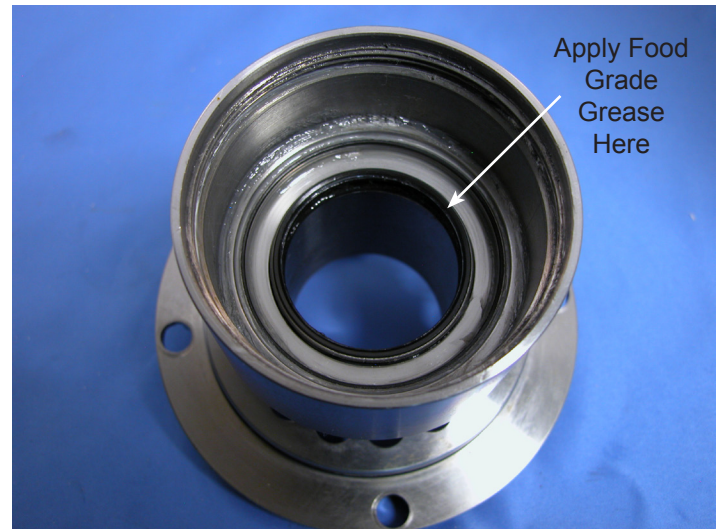

Replace parts as required. Re-grease bearing with Scotsman part no. A36808-001 bearing grease. Replace top seal, and check the o-rings, replace if cut or torn.

7. Reverse to reassemble: specific tools and materials are required to install properly.

a. Add food grade grease such as Scotsman part number 19-0569-01 to the seal area before installing on the auger.

b. Check the seal to shaft areas for cuts, or rough spots: none are permitted.

N0922L, N1322L, F1222L, F1522L Remote Low Side Service Manual Includes Prodigy Plus Repair Procedures: The Auger

Turn off the water to the machine, and unclip the evaporator drain hose, pull it down and drain the evaporator into the bin or a container.

1. Remove the the top panel.
2. Remove ice chute cover.
3. Unscrew ice sweep.
4. Remove ice chute body.
5. The auger and breaker/bearing may now be removed as an assembly.
 - a. Unscrew 4 allen head cap screws holding breaker to evaporator.
 - b. Lift up on breaker and remove auger from evaporator.

Note: If the auger is stuck, the breaker must be removed from the auger.

The breaker may be removed from the auger and evaporator without disturbing the auger.

- a. Unscrew breaker cover from breaker (left hand threads)
- b. Unscrew auger stud from top of auger.
- c. Unscrew 4 allen head cap screws holding breaker to evaporator.
- d. Lift up & remove breaker from evaporator.
- e. If the auger is stuck use a slide hammer type puller to pull on the auger at the threaded hole. The size of that hole is 5/8"-18.

Inspect the auger, see the next page.



Ice Sweep Removed

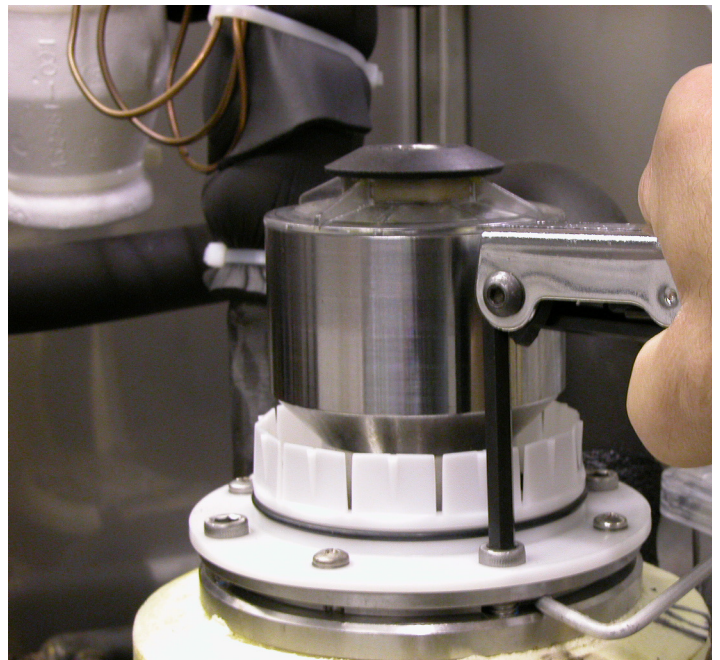

Remove allen head cap screws

N0922L, N1322L, F1222L, F1522L Remote Low Side Service Manual Includes Prodigy Plus Auger and Evaporator Inspection

The auger must be carefully inspected for wear and scale. There are also wear areas like the top bearing surface and the edges of the flights. The edges of the auger have horizontal serrations and highly machined areas in between. If the auger has contacted the evaporator wall, it will have very rough flight edges and should be replaced.

Scale forms on the auger during normal ice making. If scale is still on the auger after cleaning in the ice machine, the scale can be removed using ice machine cleaner and a nylon scrub pad.

Inspect the auger, the critical areas of the auger are:

1. The auger body. It should be clean and shining. Sometimes an auger will appear clean when wet, but after it is dry it will be seen to be stained. Scrub the auger with ice machine cleaner and hot water.

Caution: Ice machine cleaner is an acid. Handle it with extreme care, keep out of the reach of children.

2. The water seal area. Because the auger has been removed, the water seal will have to be replaced. Remove the water seal top half from the auger, and remove any sealant or debris from the shoulder of the auger where the water seal was.

Inspect the evaporator's interior. The interior is stainless steel that should be bright and shiny when dry. If it isn't the scale on the surface must be removed. To remove scale:

1. Remove the water seal; it will have to be replaced.
2. Use a brass wire brush and scrub the interior of the evaporator vertically to remove any scale.
3. Clean up any debris from the top of the gear reducer.



Example of a Clean Auger



Example of Scale Build Up on Evaporator Wall

N0922L, N1322L, F1222L, F1522L

Remote Low Side Service Manual Includes Prodigy Plus Repair Procedures: The Water Seal:

(Assuming all steps to remove the auger have been performed.)

1. The gear motor/evaporator assembly will have to be exposed.
2. Remove the 4 hex head cap screws holding the evaporator to the gear motor assembly. Lift the evaporator up and off of the gear motor.

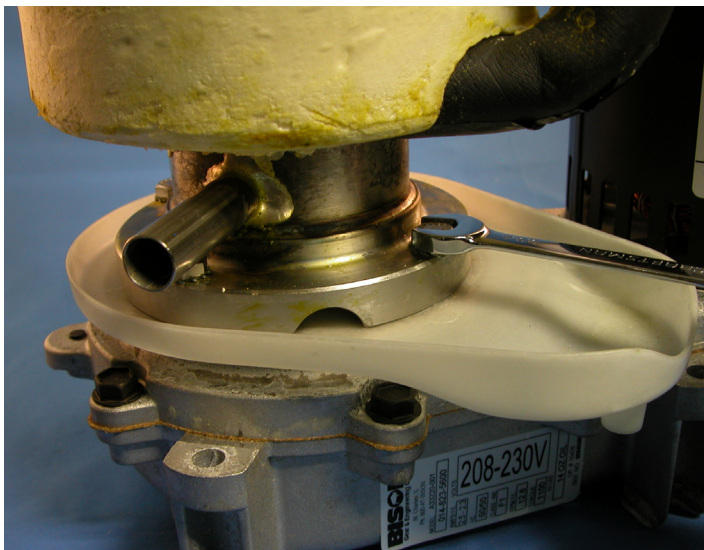

3. Remove the snap ring or wire retainer from the groove under the water seal.

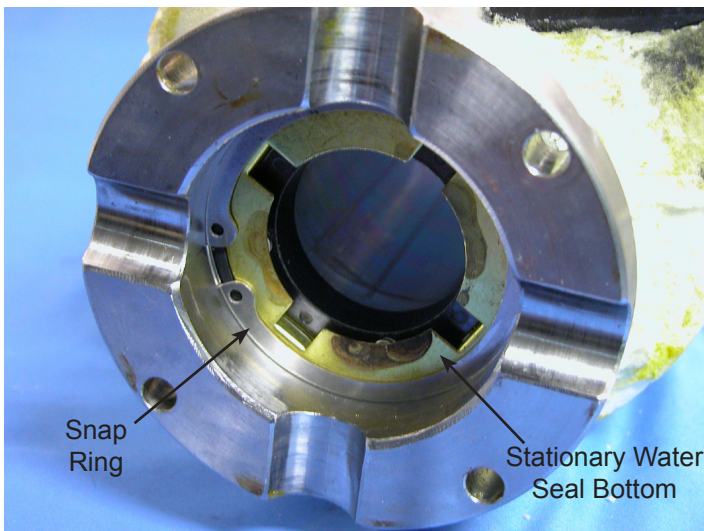

4. Pull or drive out the lower half of the water seal.

Tip: Push one side of seal in so the seal is turned 90 degrees to the evaporator and pull it out.

To Replace the Water Seal:

1. Lubricate the water seal with a thin coating of food grade grease or oil, and push the water seal into the bottom of the evaporator slightly past the groove for the snap ring.
2. Replace the snap ring and pull the water seal down against it.
3. The part of the water seal that rotates with the auger must also be replaced. Remove the old part from the auger and clean the mounting area.
4. Place a small bead of food grade silastic sealant (such as 732 RTV or Scotsman part number 19-0529-01) on the area of the auger where the water seal is to be mounted.
5. Carefully push the water seal (rubber side against the auger shoulder and the silastic sealant).

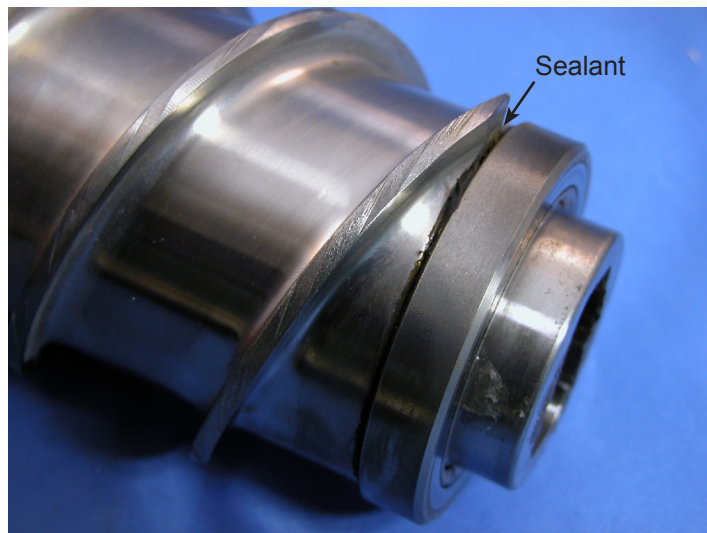

Do not get any sealant onto the face of the seal.

6. Allow the auger and seal to air dry until the sealant is dry on the surface.
7. If the original water seal was leaking, it would be a good idea to inspect the interior of the gear motor.

N0922L, N1322L, F1222L, F1522L

Remote Low Side Service Manual Includes Prodigy Plus Repair Procedures: Replace the Evaporator:

(Assuming all the steps for removal of the thrust bearing, breaker, auger, and water seal have been performed.)

1. Close ball valves to isolate machine.
2. Recover the refrigerant from the ice maker.
3. Unsweat the refrigerant connections:
 - a) At the thermostatic expansion valve outlet. Heat sink the TXV body when unsweating or resweating the adjacent tubing.
 - b) At the suction line at the joint about 3" from the evaporator.
4. Remove the evaporator.
5. Unsweat the drier from the liquid line.
6. After installing a new water seal in the new evaporator (see "To Replace the Water Seal") sweat in the new evaporator at the old tubing connections.
7. Install an new drier in the liquid line.
8. Evacuate the system until dehydrated, then weigh in the nameplate charge. Check for leaks.
9. Install auger, breaker, breaker bearing assembly, and ice discharge chute in reverse order of disassembly.
10. Open ball valves.

To Reassemble the Evaporator and Auger

1. After the gear motor has been inspected, fasten the evaporator to the gear motor. Torque the bolts to 110 inch pounds.
2. Lower the auger into the evaporator barrel, slightly turning it to match up with the drive end. Do Not Drop Into the Evaporator.
3. Complete the reassembly by reversing the disassembly for the breaker & thrust bearing assembly.

N0922L, N1322L, F1222L, F1522L

Remote Low Side Service Manual Includes Prodigy Plus

Repair Procedures: The gear reducer

(Assuming that the procedures through removal of the water seal have been performed.)

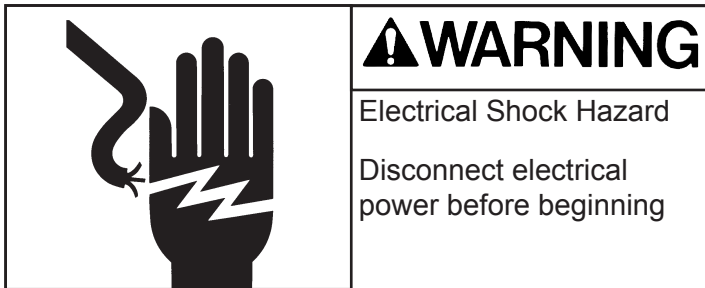

1. Remove the electrical wires from the gear drive motor.
2. Unscrew the 4 cap screws holding the gear motor to the ice machine.
3. Remove the gear motor from the ice maker.

To Inspect the gear motor.

1. Remove the cap screws holding the gear motor case halves together and pry the two cases apart.
2. To lift off the cover, lift up until you can feel internal contact, then pull the cover towards the output gear end, and then lift the cover (with drive motor attached) up and away from the gear motor case.

Note: The case cover output gear, bearings, and shaft are one pressed together assembly. Replace as a unit.

3. Inspect the oil, gears, and bearings. If the oil level and condition is acceptable, quickly check the gears and bearings. They are likely to be fine if the oil is.

If there is evidence of water in the oil (rusty bearings and gears; the oil having a creamy white appearance; oil level too high) carefully inspect the bearings and gears. If in doubt about the condition of a part, replace it. The oil quantity is 14 fluid ounces, do not overfill.

Note: The gears and bearings are available only as pressed together sets

4. After replacing parts as required, (if any) reassemble the gearcase. The two smaller gears and the oil should be in the lower case, the output gear will be with the cover. As you lower the cover onto the lower case, cover will have to be moved closer to the second gear after the output gear has cleared the second gear top bearing.

5. After the case is together, and the locating pins are secure in both ends, replace all cap screws.

6. Bench test the gear motor, check for oil leaks, noise, and amp draw.



Replacement Drive Motor

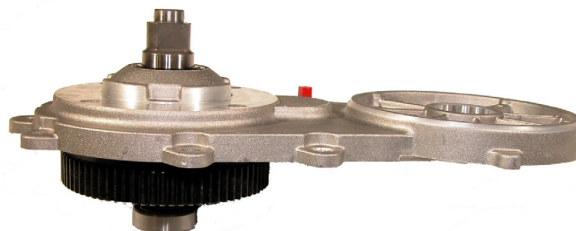

Gear Case Cover Assembly

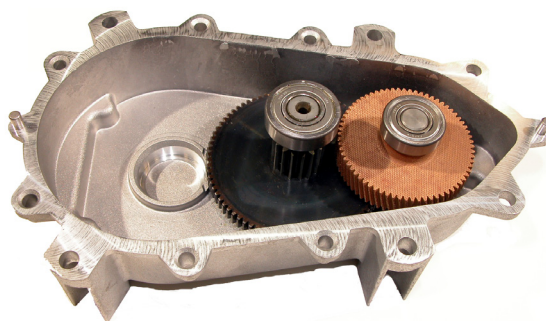

Gear Case with First and Second Gears

N0922L, N1322L, F1222L, F1522L
Remote Low Side Service Manual Includes Prodigy Plus
Repair Procedures: Thermostatic Expansion Valve

1. Remove front panel.
2. If the machine was in operation, push and release the off button to shut it down.
3. Disconnect electrical power.
4. Shut ball and liquid line access valves to isolate machine.
5. Recover refrigerant from head.
6. Remove insulation covering expansion valve and bulb.
7. Remove strap securing bulb to suction line.
8. Unsweat the expansion valve from the liquid line. Remove it.
9. Unsweat the drier from the liquid line. Remove it.
10. Connect nitrogen to discharge access valve.
11. Immediately place new valve in ice machine.
12. Open nitrogen bottle and braze expansion valve inlet and outlet joints together. Braze new drier into system.
13. Shut off nitrogen, shut access valves.
14. Evacuate to at least 300 microns.
15. Open ball and liquid access valves
16. Attach bulb to suction line. Position at 4 or 8 o'clock on the tube. Secure tightly but do not crush the bulb with the strap.
17. Attach valve and bulb insulation.
18. Reconnect electrical power.
19. Return all panels to their original positions.

SCOTSMAN ICE SYSTEMS

775 Corporate Woods Parkway

Vernon Hills, IL 60061

800-726-8762

www.scotsman-ice.com