

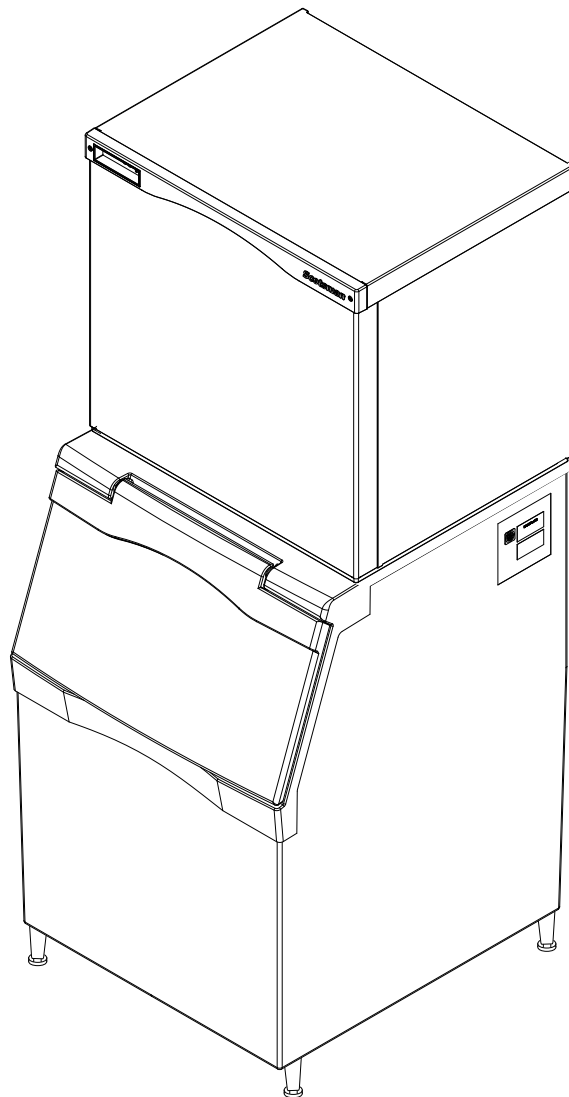

Installation and User's Manual for Remote Condenser Modular Cuber

Models: C0522, C0530, C0630, C0830
and C1030

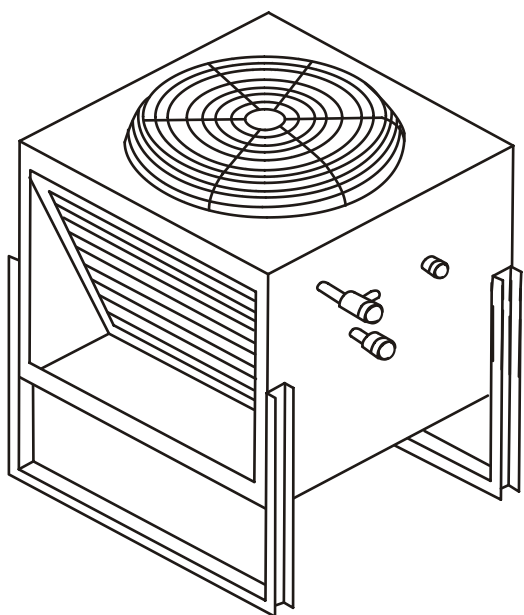

**C0522 through C1030
Remote Condenser Models - User Manual**

Introduction

The design of this modular remote cuber is the result of years of experience with remote ice machine refrigeration systems. Standard features of this product include front accessible on-off switches, always-visible indicator lights, mechanical assist ice harvest for extra efficiency, automatically adjusting water purge and a control system that optimizes system operation.

The Installation section provides the trade person with the information needed to properly install and start up this ice system. The Use and Operation section provides the user with the information needed to use the machine. The Maintenance section contains the instructions and schedules for the sanitation and cleaning of the machine.

This installation and user manual is divided into three sections: Installation, Use and Operation and Maintenance.

Contents

Installation: Product Specifications	2
Model Number Description	3
C0522 Cabinet Dimensions	4
C0530, C0630, C0830 and C1030 Cabinet Dimensions	5
Product Description and Electrical Requirements	6
Water	7
Panel Removal	8
Remote Condenser Location	9
For The Installer: Remote Condenser	10
Precharged Line Routing	11
Coupling Instructions	12
Plumbing Requirements	13
Electrical	14
Final Check List:	15
Initial Start Up	16
Adjustments	17
Use and Operation	18
Control Switches	19
Options and Other Information	20
Cleaning, Sanitation and Maintenance	21
Remote condenser	23
What to do before calling for service	24

C0522 through C1030 Remote Condenser Models - User Manual

Installation: Product Specifications

Location Limitations

This ice system is made up of three parts, the ice making machine, or head; the remote condenser; and the interconnecting tubing. The ice making machine must be installed indoors, in a controlled environment. Space must be provided near the machine for service access. The remote condenser may be installed above or below the ice machine, per the limits stated later in this manual. The remote condenser may be installed outdoors within the temperature limits listed below. The interconnecting tubing must be installed per the directions stated in this manual, and the amount of tubing exposed to uncontrolled temperatures must be minimized.

Space Limitations

Although the machine will function with no clearance to the top and sides, some space must be allowed for service access. Building the machine in with no access will cause higher service cost, in many cases this extra cost may not be covered by warranty.

Environmental Limitations, ice machine:

	Minimum	Maximum
Air temperature	50°F.	100°F.
Water temperature	40°F.	100°F.
Water Pressure	20 psi	80 psi

Environmental Limitations, remote condenser

	Minimum	Maximum
Air temperature	-20°F.	120°F.

Power Supply

	Minimum	Maximum
115 volt model	104 volts	126 volts
208-230 volt model	198 volts	253 volts

Warranty Information

The warranty statement for this product is provided separately from this manual. Refer to it for applicable coverage. In general warranty covers defects in material and workmanship. It does not cover maintenance, corrections to installations, or situations when the ice machine is operated in circumstances that exceed the limitations printed above.

Product Information

The machine is a specialized version of a modular cuber. A modular cuber does not include any ice storage, it is designed to be placed onto an ice storage bin or ice dispenser. Many installations only require the matching bin, but some will need an adapter to be placed between the ice machine and the bin or dispenser. Additionally, the machine must be connected to the correct remote condenser and use the correct pre-charged tubing.

The machine is supplied with a full refrigerant charge, field charging is not required.

This product cannot be stacked. See the chart for application information.

**C0522 through C1030
Remote Condenser Models - User Manual**

Model Number Description

Example

- C0630SR-32B
- C=cuber
- 06=nominal capacity in 100s of pounds
- 30=nominal width of cabinet in inches
- S=cube size, S=small or half dice, M=medium or full dice
- R=condenser type. R=Remote
- -32=Electrical code. -32=208-230/60/1, -3= 208-230/60/3
- B=series revision code. B=2nd series.

Note: In some areas of this manual model numbers may include only the first five characters of the model number, meaning that cube size, condenser type and voltage differences are not critical to the information listed there.

Options:

There are several options available for field installation. They include:

- KVS - Vari-Smart Adjustable ice level system
- KSB - SmartBoard Advanced feature board

Some installations require bin or dispenser adapters. See the table below.

Standard bin applications – Adapter information

Model	B222 or B322	B530P, B330P, B530S	B842S	B948S
C0522	Direct fit	KBT27	Not available	Not available
C0530, C0630, C0830, C1030	Does not fit	Direct fit	KBT28	KBT22

Hotel Dispensers

Although an unlikely use for a remote cuber, the HD22 and HD30 can be used without an adapter:

HD22 – use with C0522R

HD30 – use with C0530R

Ice and Beverage Dispensers - Adapter Information

Model	ID150	ID200 or ID250
C0522	KBT42	KBT43
C0530, C0630, C0830, C1030	Does not fit	KBT44

Other bins and applications:

Note the drop zone and optional ultrasonic sensor locations in the illustrations.

Scotsman ice systems are designed and manufactured with the highest regard for safety and performance. They meet or exceed the standards of UL and NSF.

Scotsman assumes no liability of responsibility of any kind for products manufactured by Scotsman that have been altered in any way, including the use of any part and/or other components not specifically approved by Scotsman.

Scotsman reserves the right to make design changes and/or improvements at any time.

Specifications and design are subject to change without notice.

**C0522 through C1030
Remote Condenser Models - User Manual**

C0522 Cabinet Dimensions

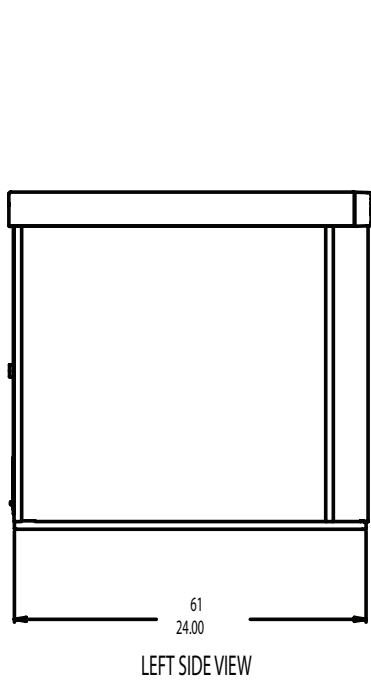

C0522 Side View

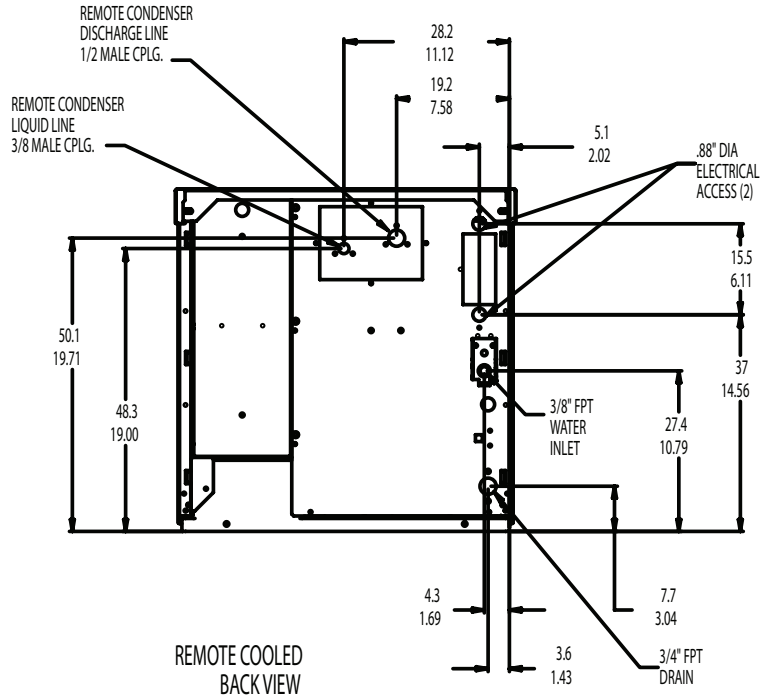

C0522 Back View

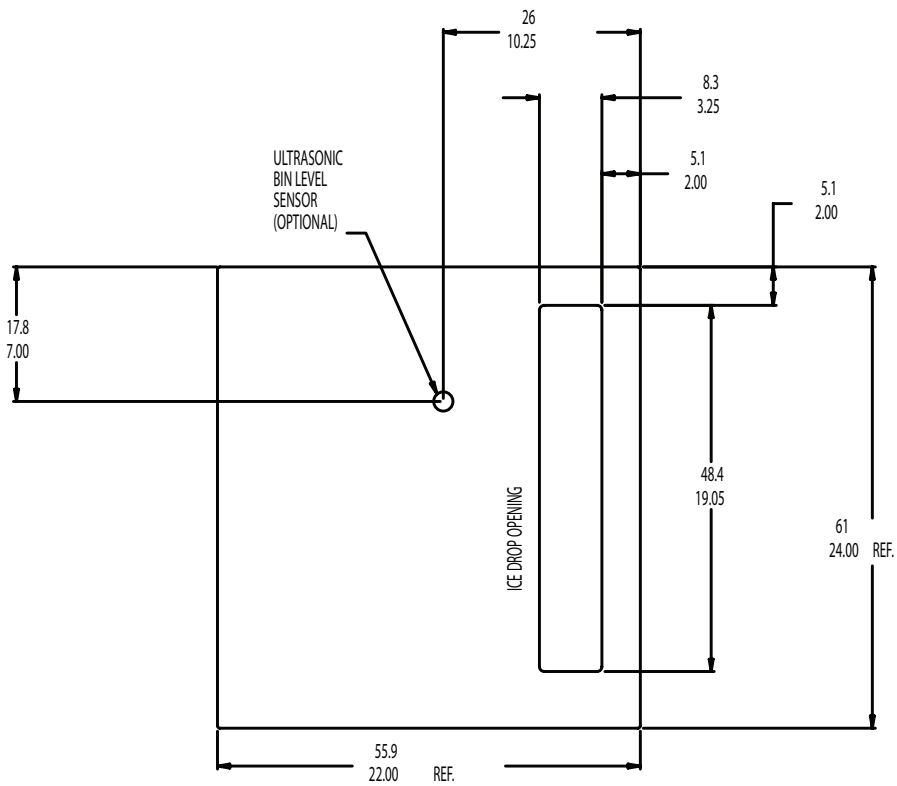

PLAN VIEW
22" PRODIGY

**C0522 through C1030
Remote Condenser Models - User Manual**

C0530, C0630, C0830 and C1030 Cabinet Dimensions

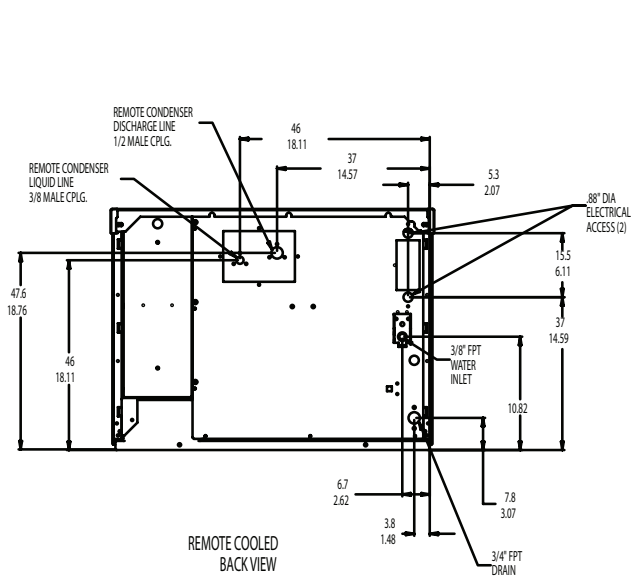

C0530, C0630 Side View

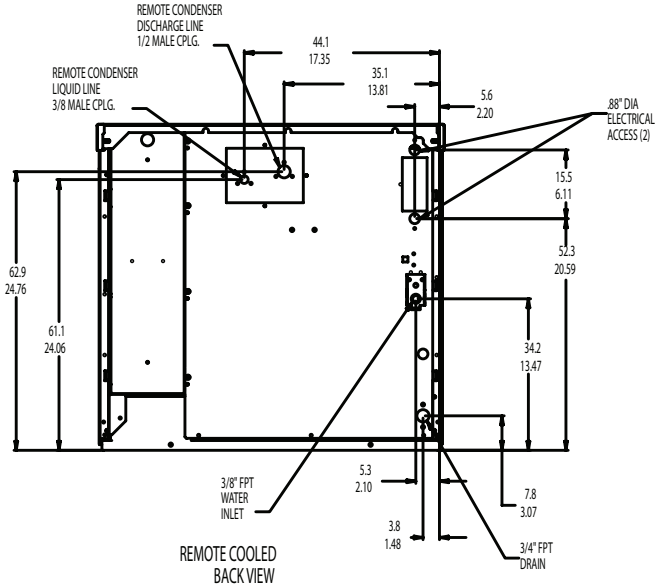

C0830, C1030 Back View

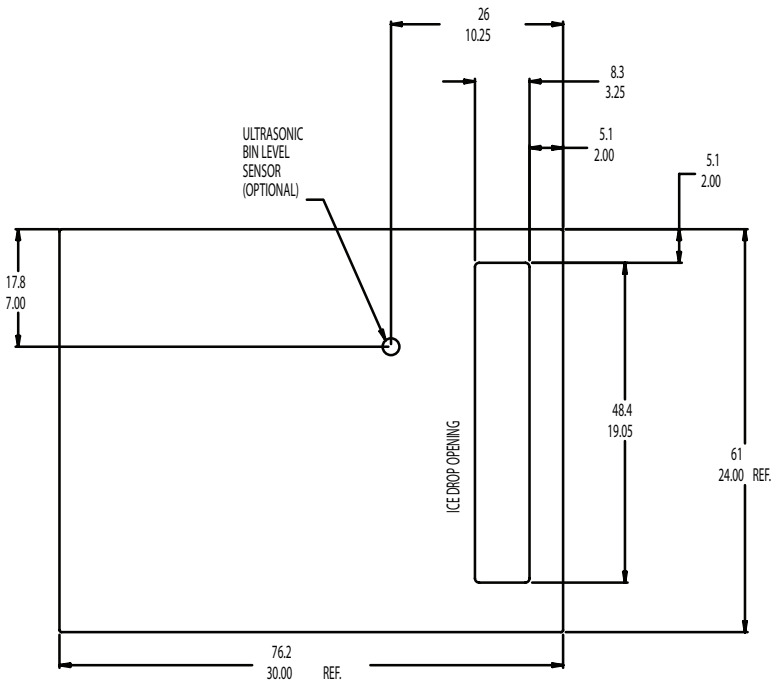

PLAN VIEW

Top View

Note: Top number is centimeters, bottom number is inches.

**C0522 through C1030
Remote Condenser Models - User Manual**

Product Description and Electrical Requirements

Dimensions w" x d" x h"	Model	Series	Electrical	Use condenser	Minimum Circuit Ampacity	Maximum Fuse Size*
22.75** x 24 x 23	C0522SR-1	A or B	115/60/1	ERC111-1	14.9	15
30.75** x 24 x 23	C0530SR-1	A or B	115/60/1	ERC111-1	14.9	15
same	C0530SR-1	C	115/60/1	ERC111-1	16.2	20
same	C0630SR-32	A or B	208-230/60/1	ERC311-32	18	20
30.75** x 24 x 29	C0830SR-32	A or B	208-230/60/1	ERC311-32	10	15
same	C0830SR-3	A or B	208-230/60/3	ERC311-32	8.2	15
same	C1030SR-32	A or B	208-230/60/1	ERC311-32	15.6	20
same	C1030SR-3	A or B	208-230/60/3	ERC311-32	10.8	15

*Or HACR circuit breakers.

** Maximum width at top panel.

Ratings include the remote condenser motor, as it is designed to be powered by the ice machine. If connecting remote condenser independently of the ice machine, use the information on the condenser's dataplate for fuse and wire sizes.

Table notes: Medium cube models have the same electrical characteristics as Small. Series revision code omitted. All the listed condensers include a headmaster valve.

Central Condenser Coils

The ice machine may be connected to a central condenser coil. The requirements are:

- Coil – not previously used with mineral oil system. Virgin coil preferred.
- Correct size (internal volume) and capacity (BTUH).
- Includes a headmaster valve for discharge pressure control. Headmaster kit available for certain MAC condensers, kit number is RCKCME6GX.
- Fan motor on all the time or controlled to be on whenever the ice machine is operating.
- Non-Scotsman condensers must have prior Scotsman Engineering approval for warranty coverage to be in effect.

Precharged tubing kits:

The ice making head's and the remote condenser's refrigeration circuits must be connected. They are designed to be connected using precharged refrigerant tubing, supplied in kits of liquid and discharge tubes. Several lengths are available, order the one that just exceeds the length needed for the site.

10"	20'	40'	75'
RTE10	RTE25	RTE40	RTE75

No additional refrigerant is required.

Note: Refrigerant charge is supplied with the ice machine.

Water

The quality of the water supplied to the ice machine will have an impact on the time between cleanings and ultimately on the life of the product. Water can contain impurities either in suspension or in solution. Suspended solids can be filtered out. In solution or dissolved solids cannot be filtered, they must be diluted or treated. Water filters are recommended to remove suspended solids. Some filters have treatment in them for dissolved solids. Check with a water treatment service for a recommendation.

RO water. This machine can be supplied with Reverse Osmosis water, but the water conductivity **must be no less than 10 microSiemens/cm**.

Potential for Airborne Contamination

Installing an ice machine near a source of yeast or similar material can result in the need for more frequent sanitation cleanings due to the tendency of these materials to contaminate the machine.

Most water filters remove chlorine from the water supply to the machine which contributes to this situation. Testing has shown that using a filter that does not remove chlorine, such as the Scotsman Aqua Patrol, will greatly improve this situation, while the ice making process itself will remove the chlorine from the ice, resulting in no taste or odor impact. Additionally, devices intended to enhance ice machine sanitation, such as the Scotsman Aqua Bullet, can be placed in the machine to keep it cleaner between manual cleanings.

Water Purge

Cube ice machines use more water than what ends up in the bin as ice. While most water is used during ice making, a portion is designed to be drained out every cycle to reduce the amount of hard water scale in the machine. That's known as water purge, and an effective purge can increase the time between needed water system cleaning. In addition, this product is designed to automatically vary the amount of water purged based on the purity of the water supplied to it. The water purge rate can also be set manually. Adjustments of purge due to local water conditions are not covered by warranty.

**C0522 through C1030
Remote Condenser Models - User Manual**

Panel Removal

1. Locate and loosen the two screws at the front edge of the top panel.
2. Pull the front panel out at the top and lift it up and off the base.
3. Remove two screws at the front edge of the top panel, and lift up the top panel until it clears the front of the side panels, then push back 1" and lift it up and off the machine.
4. Locate and loosen the screws holding each side panel to the base.
5. Pull the side panel forward to release it from the back panel.

This manual covers several models of remote cubers. The model number on the ice machine can be found either on the dataplate, which is on the back panel, or the serial number tag, which is behind the front panel. See the illustration for the locations of the dataplate and the serial number tag.

The remote condenser has a separate model and serial number. Its model and serial number is on the dataplate on the condenser near the quick connect fittings.

Write the model and serial numbers here:

	Model	Serial Number
Ice machine		
Bin		
Condenser		

Write the day of start up here: _____

Switch Bezel

All models ship with the On and Off switches front accessible. If desired, the On and Off switches can be covered up to prevent unauthorized use by changing the bezel in the front panel's trim strip. A cover up bezel is available from the local Scotsman distributor.

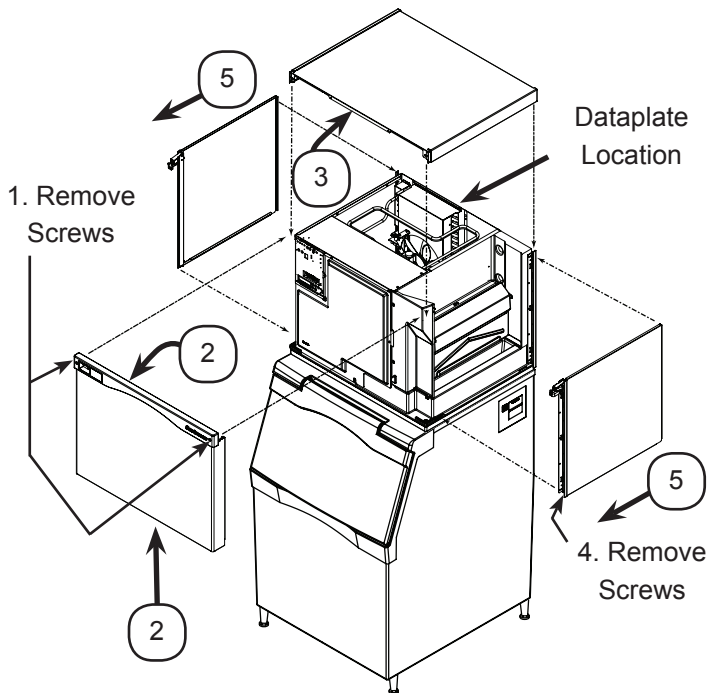

Dataplate Location and panel Removal

Uncrate and Set Up

Begin with the ice storage bin or dispenser. If a bin, remove the carton, and, using part of the carton as a cushion, tip the bin on its back to remove the skid. Attach the supplied legs or optional casters. Return the bin to a normal, upright position.

Check the bin top gasket for rips or gaps. If recycling an older bin, replace the gasket or repair with food grade sealant prior to placing the ice machine on the bin.

Install the bin top adapter or ice dispenser adapter, if one is required for the application.

If the ice machine has not been unpacked, do so now. Remove the carton from the skid. Lift the ice machine off the skid directly onto the bin.

Note: The machine is heavy. Use a mechanical lift if necessary.

Secure the ice machine to the bin with the hardware provided (two metal straps and four bolts).

Place the bin and ice machine in the selected location and level it using the bin leg levelers.

Remote Condenser Location

Use the following for planning the placement of the condenser relative to the ice machine

Location Limits - condenser location must not exceed ANY of the following limits:

- Maximum rise from the ice machine to the condenser is 35 physical feet
- Maximum drop from the ice machine to the condenser is 15 physical feet
- Physical line set maximum length is 100 feet.
- Calculated line set length maximum is 150.

Calculation Formula:

- Drop = $dd \times 6.6$ (dd = distance in feet)
- Rise = $rd \times 1.7$ (rd = distance in feet)
- Horizontal Run = $hd \times 1$ (hd = distance in feet)
- Calculation: Drop(s) + Rise(s) + Horizontal Run = $dd+rd+hd$ = Calculated Line Length

Configurations that do NOT meet these requirements must receive prior written authorization from Scotsman.

Do NOT:

Route a line set that rises, then falls, then rises.

Route a line set that falls, then rises, then falls.

Calculation Example 1:

The condenser is to be located 5 feet below the ice machine and then 20 feet away horizontally.

$5 \text{ feet} \times 6.6 = 33$. $33 + 20 = 53$. This location would be acceptable

Calculation Example 2:

The condenser is to be located 35 feet above and then 100 feet away horizontally. $35 \times 1.7 = 59.5$.

$59.5 + 100 = 159.5$. 159.5 is greater than the 150 maximum and is NOT acceptable.

Operating a machine with an unacceptable configuration is misuse and will void the warranty.

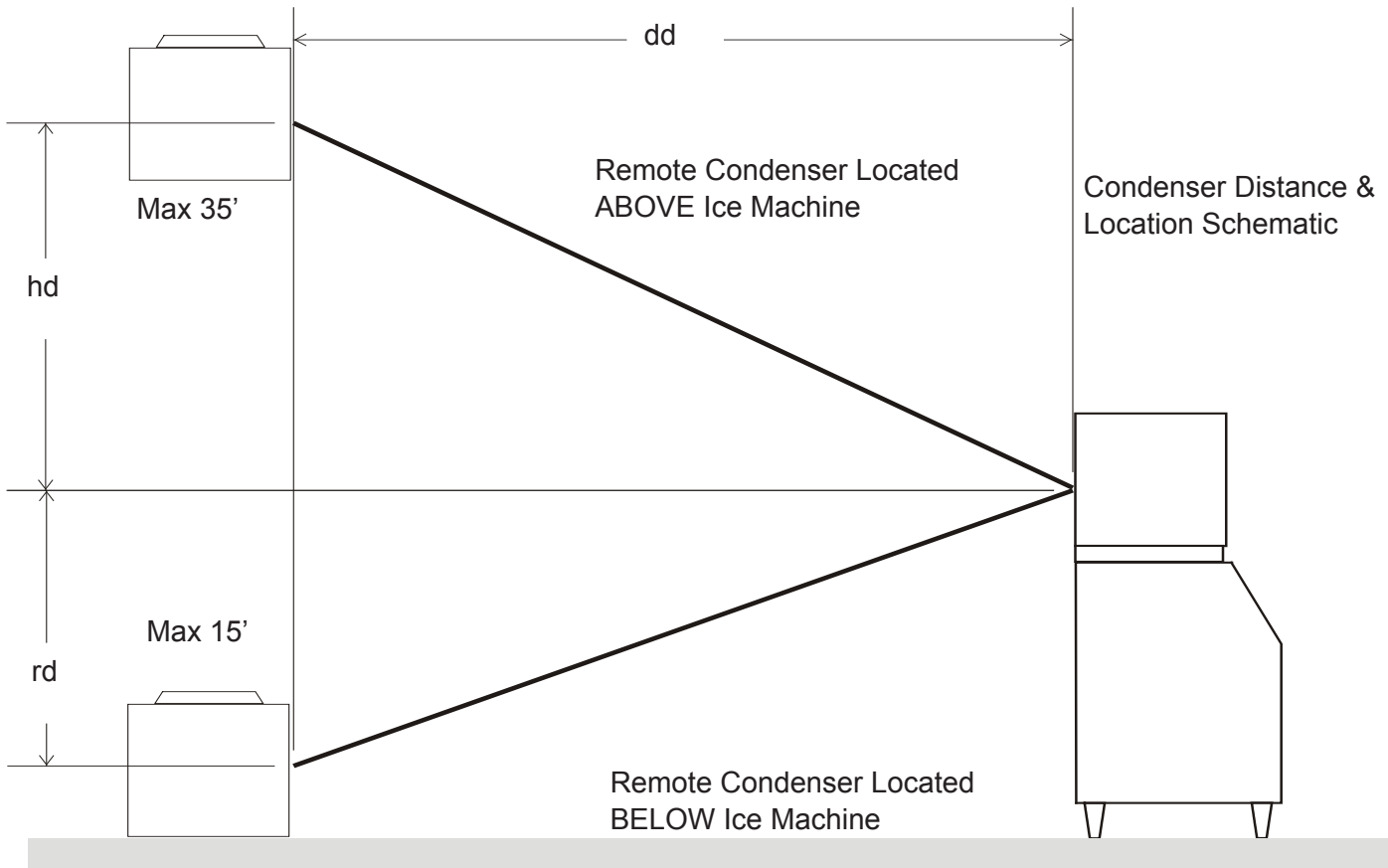

**C0522 through C1030
Remote Condenser Models - User Manual**

For The Installer: Remote Condenser

Locate the condenser as near as possible to the interior location of the ice machine.

Note: The location of the condenser is relative to the ice machine is LIMITED by the specification on the prior page.

Meet all applicable building codes.

Roof Attachment

Install and attach the remote condenser to the roof of the building, using the methods and practices of construction that conform to the local building codes, including having a roofing contractor secure the condenser to the roof.

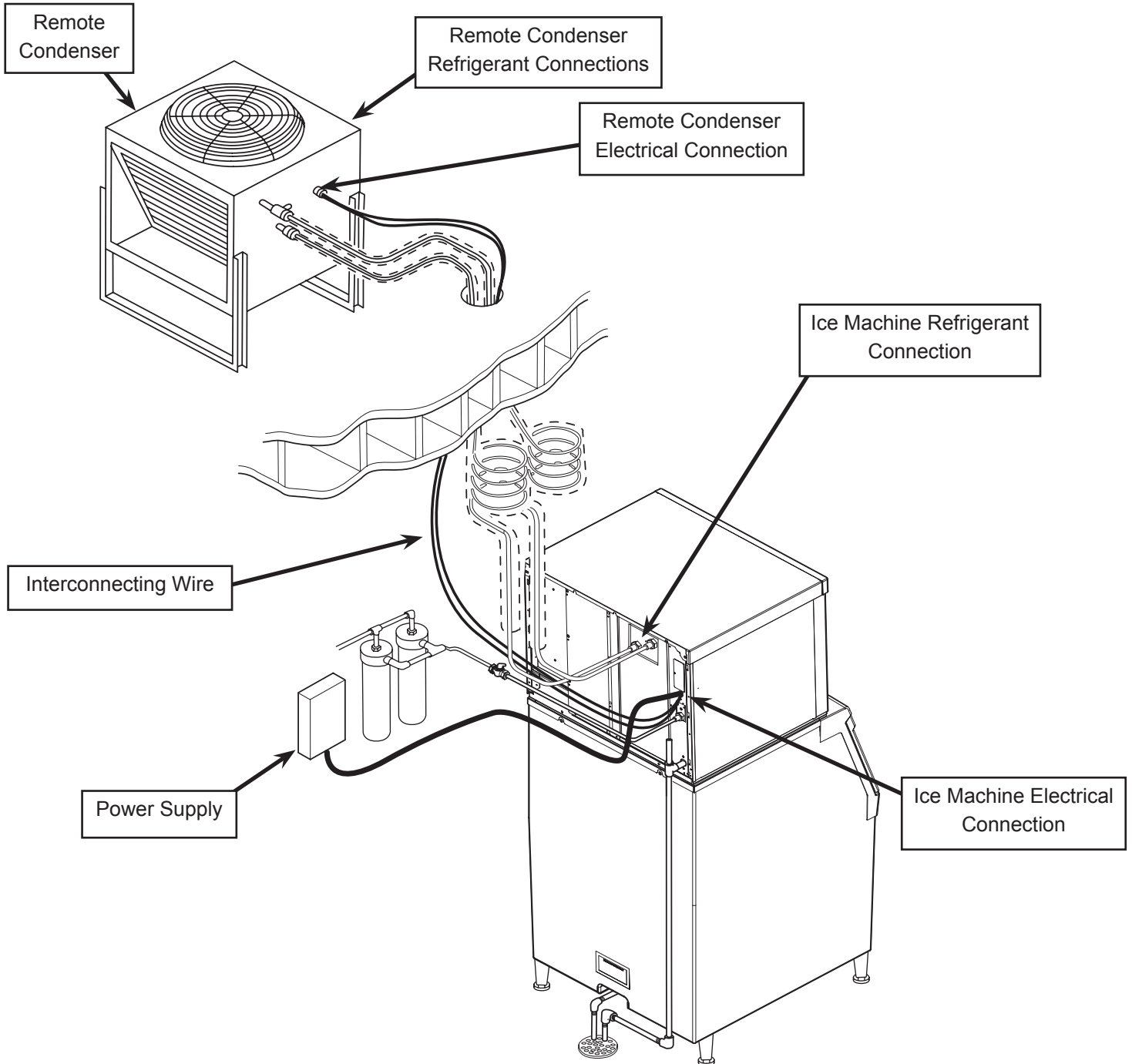

Typical System Installation

C0522 through C1030 Remote Condenser Models - User Manual

Precharged Line Routing

Do not connect the precharged tubing until all routing and forming of the tubing is complete. See the Coupling Instructions for final connections.

1. Each set of pre-charged tubing lines contains a 3/8" diameter liquid line, and a 1/2" diameter discharge line. Both ends of each line have quick connect couplings, the end without access valves goes to the ice maker.

Note: The openings in the building ceiling or wall, listed in the next step, are the minimum sizes recommended for passing the refrigerant lines through.

2. Have the roofing contractor cut a minimum hole for the refrigerant lines of 1 3/4". Check local codes, a separate hole may be required for the electrical power supply to the condenser.

Caution: Do NOT kink the refrigerant tubing while routing it.

3. Route the refrigerant tubes thru the roof opening. Follow straight line routing whenever possible. Excess tubing may EITHER be coiled up INSIDE the building OR cut out prior to connection to the ice maker and condenser.

If the excess tubing is cut out, after re-brazing the tubing must be evacuated prior to connection to the ice maker or condenser.

If the excess tubing is to be coiled, spiral it horizontally to avoid excess trapping in the lines.

5. Have the roofing contractor seal the holes in the roof per local codes

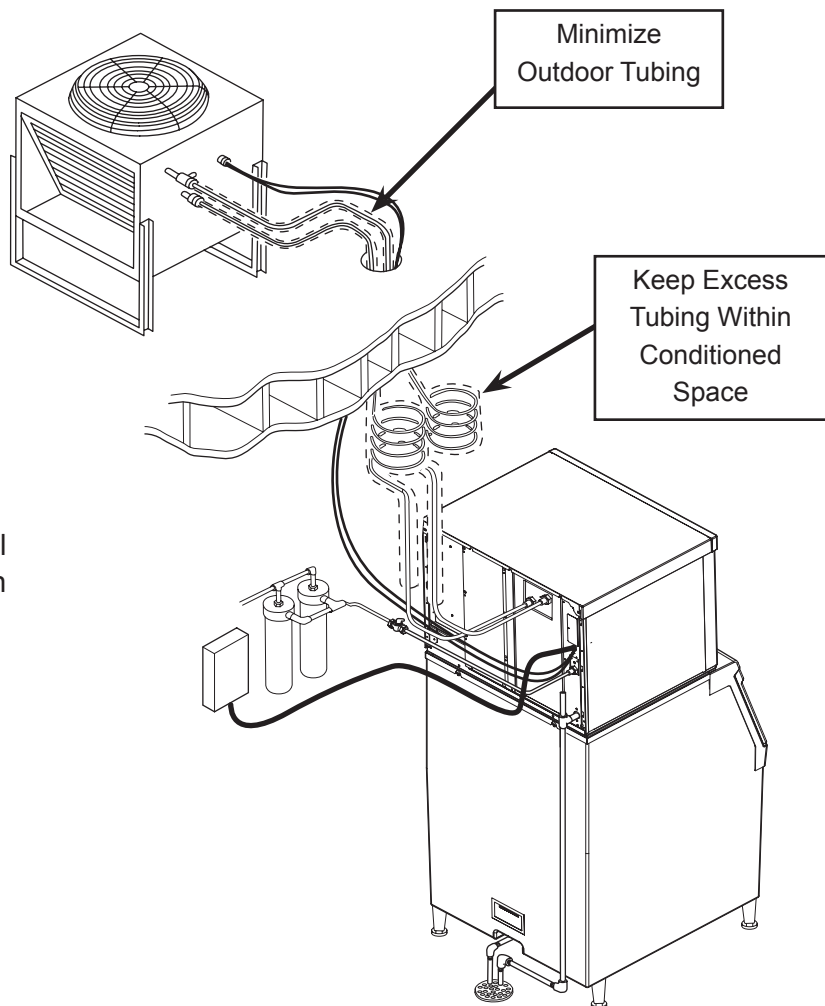

C0522 through C1030 Remote Condenser Models - User Manual

Coupling Instructions

The couplings on the ends of the pre-charged line sets are self-sealing when installed properly.

Follow these instructions carefully.

These steps must be performed by an EPA Certified Type II or higher technician.

Initial Connections

1. Remove the protector caps and plugs. Wipe the seats and threaded surfaces with a clean cloth to remove any possible foreign matter.
2. Lubricate the inside of the couplings, especially the threads with refrigerant oil.

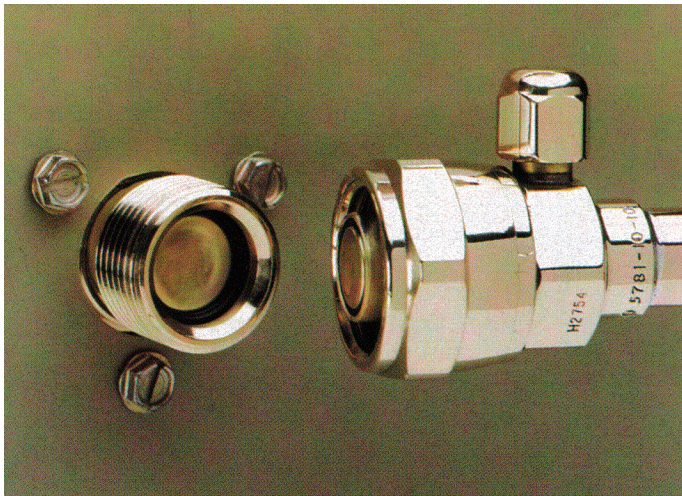

3. Position the fittings on the correct connections on the condenser and ice machine.

- Liquid
- Discharge

Final Connections:

- 4a. Begin by tightening the couplings together by hand until it is certain that the threads are properly engaged.
- 4b. Then using two wrenches tighten the coupling until it bottoms out or a definite increase in resistance is felt.

It is important that **ONLY** the nut on the pre-charged tube be turned, or the diaphragms will be torn out by the piercing knives and they will be loose in the refrigeration system.

Note: As the couplings are tightened, the diaphragms in the quick connect couplings will begin to be pierced. As that happens, there will be some resistance to tightening the swivel nut.

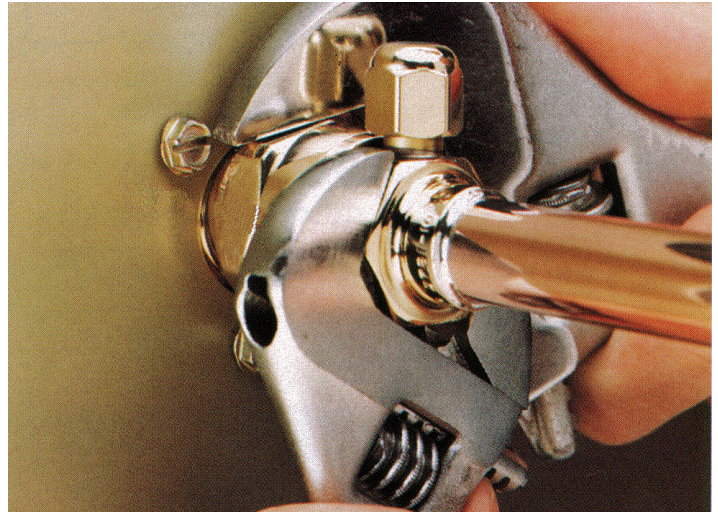

4c. Continue tightening the swivel nut until it bottoms out or a very definite increase in resistance is felt (no threads should be showing).

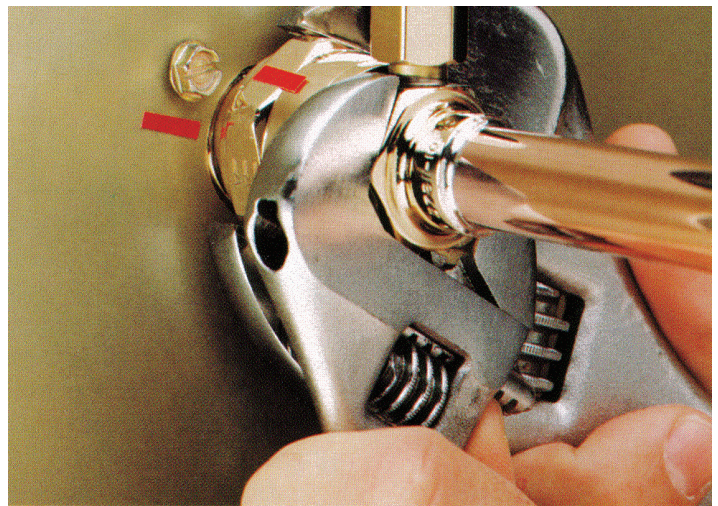

5. Use a marker or pen to mark a line on the coupling nut and unit panel. Then tighten the coupling nut an additional one-quarter turn. The line will show the amount that the nut turns. Do **NOT** over tighten.
6. After all connections have been made, and after the receiver valve has been opened (do not open yet), check the couplings for leaks.

C0522 through C1030 Remote Condenser Models - User Manual

Plumbing Requirements

All models require connection to cold, potable water. A hand actuated valve within site of the machine is required. There is a single 3/8" FPT inlet water connection.

Water Filters Install a new cartridge if the filters were used with a prior machine.

All models require drain tubing to be attached to them. There is a single 3/4" FPT drain fitting in the back of the cabinet.

Install new tubing when replacing a prior ice machine, as the tubing will have been sized for the old model and might not be correct for this one.

1. Connect water supply to water inlet fitting.

Note: This NSF listed model has a 1" anti-back flow air gap between the potable water inlet tube end and the highest possible reservoir water level, no back flow device is required.

2. Connect drain tubing to drain fitting.

3. Route the drain tubing to building drain. Follow local codes for drain air gap.

Use rigid drain tubes and route them separately – do not Tee into the bin's drain.

Vent the reservoir drain. A vertical vent at the back of the drain, extended about 8 – 10" will allow the

gravity drain to empty and also keep any surges during draining from discharging water.

Horizontal runs of drain tubing need a 1/4" per fall per foot of run for proper draining.

Follow all applicable codes.

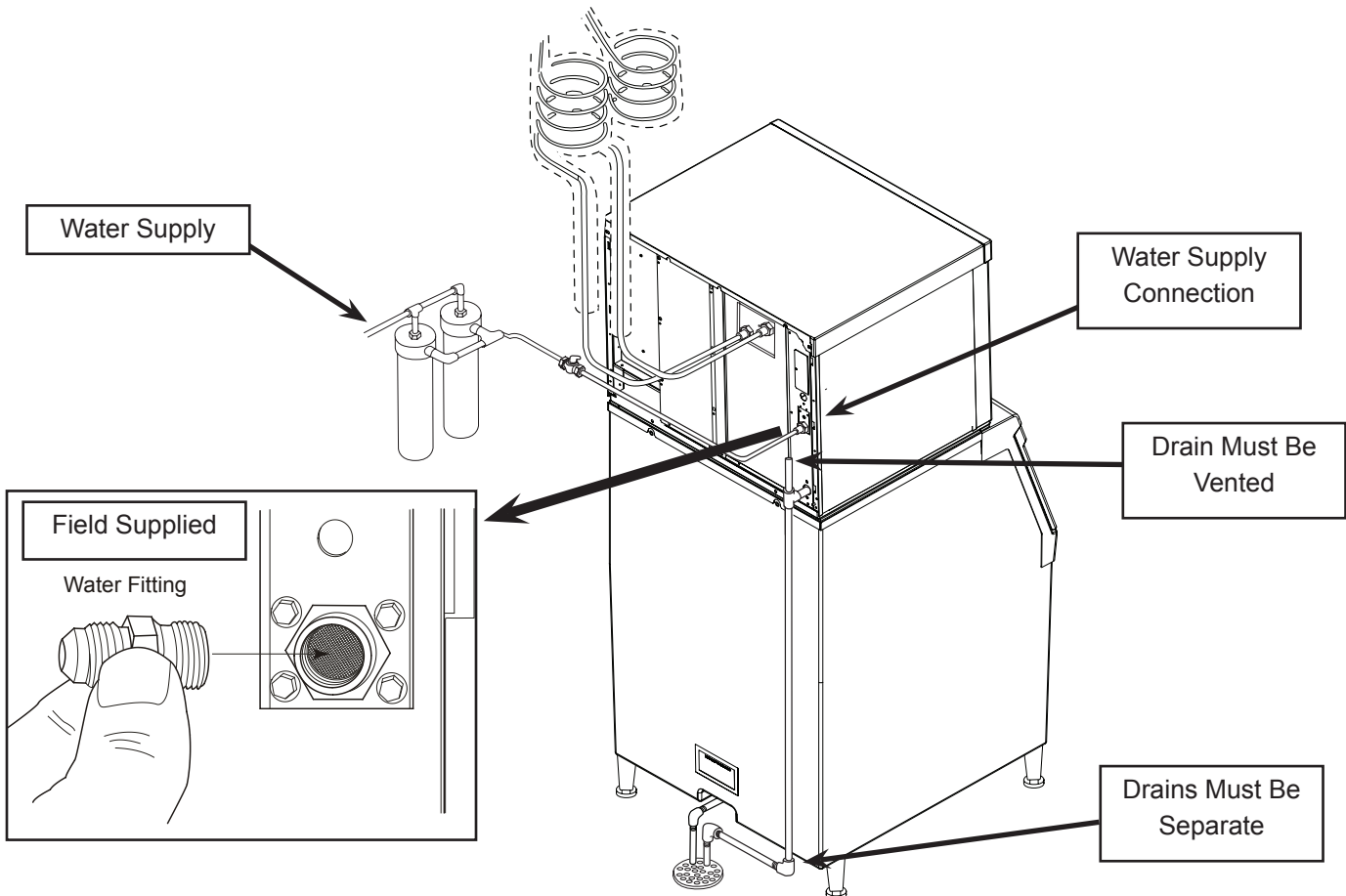

Water Supply and Drain Illustration

C0522 through C1030 Remote Condenser Models - User Manual

Electrical

The machine is not supplied with a power cord, one must either be field installed or the machine hard-wired.

The dataplate on the back of the cabinet details the power requirements, including voltage, phase, minimum circuit ampacity and maximum fuse size.

HACR type circuit breakers may be used in place of fuses. Extension cords are not permitted. Use of a licensed electrician is recommended.

The ice maker is designed to operate on its own electrical circuit and must be individually fused.

Voltage variation must not exceed the limits listed earlier.

The remote condenser is designed to be powered from the ice machine. A separate knockout hole has been provided in the ice maker electrical junction box.

Electrical connections are made inside the junction box in the back panel of the ice machine.

1. Remove the junction box cover and route the power cord through the access hole and properly attach the power supply wires to the leads in the junction box.
2. Attach the remote condenser fan motor wires to the wires in the junction box tagged "fan motor leads".
3. Install field supplied strain reliefs per code.
4. Attach a ground wire to the ground connection in the junction box.
5. Check voltage when complete.
6. Return the junction box cover to its original position and secure with the original screws.

Follow all applicable local, state and national codes.

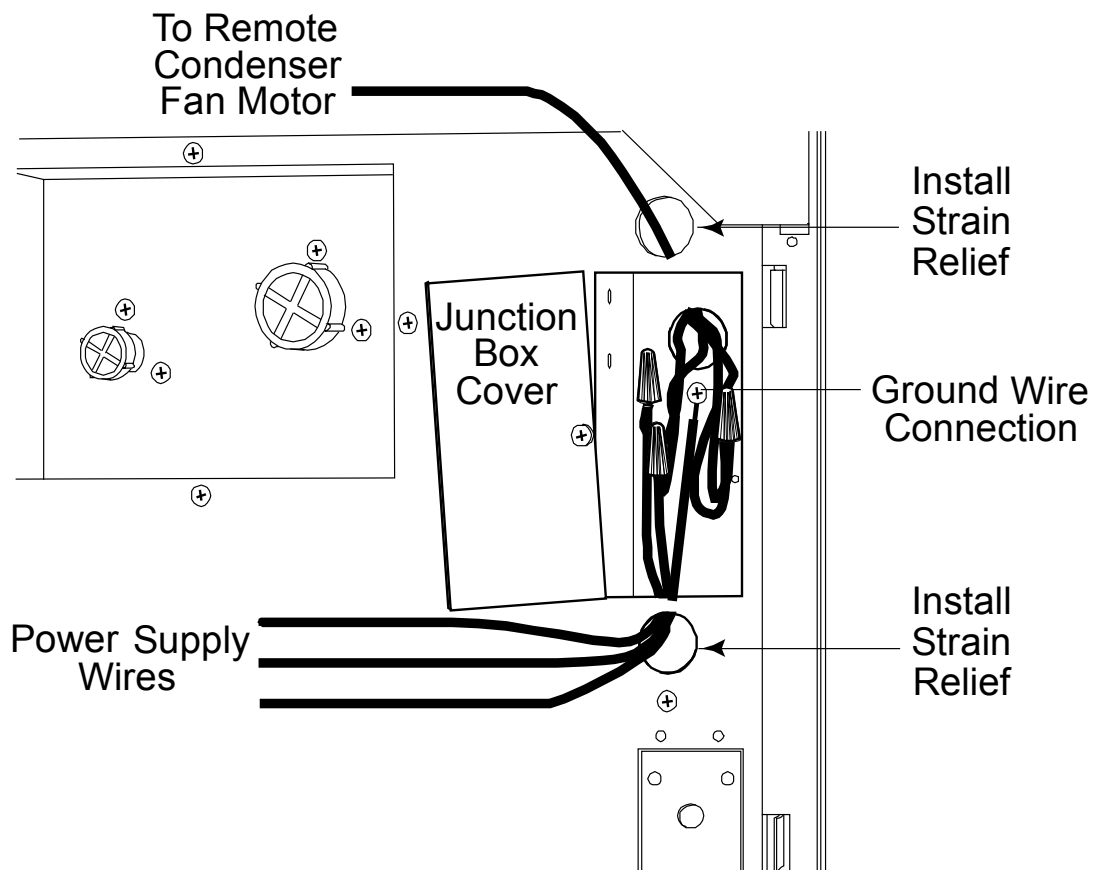

Electrical Connection Detail

January 2014

Page 14

C0522 through C1030 Remote Condenser Models - User Manual

Final Check List:

1. Is the unit located indoors in a controlled environment?
2. Is the unit located where it can receive adequate cooling air?
3. Has the correct electrical power been supplied to the machine?
4. Have all the water supply connections been made?
5. Have all the drain connections been made?
6. Has the remote condenser been properly installed?
7. Has the interconnecting tubing been properly routed between the remote condenser and the ice machine?
8. Have the quick connects been properly connected?
9. Has the power supply wire from the ice machine to the remote condenser been properly run and connected?
10. Has the unit been leveled?
11. Have all unpacking materials been removed?
12. Is the water pressure adequate?
13. Have the drain connections been checked for leaks?
14. Has the bin interior been wiped clean or sanitized?
15. Have any water filter cartridges been replaced?
16. Have all required kits and adapters been properly installed?

**C0522 through C1030
Remote Condenser Models - User Manual**

Initial Start Up

1. Remove front and left side panels. Check machine for any packing or wires rubbing moving parts. Note location of control board in upper left corner of the machine's front.
2. Switch on the electrical power to the machine. Observe that some of the control's indicator lights glow and its display shows O.
3. Wait 4 hours for the compressor's crankcase heater to warm up the oil in the compressor.
6. When the ice has frozen enough, the Ready for Harvest indicator light will be on steady. After it's been on steady for a few seconds Harvest will begin.
7. The display shows an H.

Start Up

1. Open the water supply valve.
2. Turn the receiver's outlet valve to the full open position.
3. Push and release the ON button.

The indicator light will begin to blink F. The purge valve will open and the water pump will start. The inlet water valve will open to add water to the reservoir. After a few seconds the purge valve will close and the water pump will stop. Water will flow into the machine until the reservoir is full. The hot gas valve and harvest assist device will activate and the liquid line solenoid valve will open, then the compressor and water pump will start. The display will show a continuous F. Five seconds later the hot gas valve will close and the harvest assist device will return to its standby position. Warm air will be discharged from the condenser coil.

4. During the Freeze cycle move the curtain and observe that the SW1 or SW2 light on the control board blinks On when the curtain moves away from the evaporator and Off when returned to its normal position.

Note: Moving the curtain during the Freeze cycle has no affect on control function, but will cause water to flow into the cube chute.

5. Observe the Ready for Harvest indicator light. It may blink early in the freeze cycle, that is normal. The control will ignore that signal for the first 6 minutes of freeze.

The hot gas valve opens and the harvest assist mechanism is activated. The purge valve opens to drain some water, when it does the inlet water valve opens to refill the reservoir. After a few seconds the purge valve closes but the inlet water valve continues to fill the reservoir. Harvest continues until the ice is released as a unit and forces the curtain to open. When the curtain opens it signals the controller which returns the unit to a freeze cycle.

8. Check the ice harvested for proper bridge thickness. The ice bridge is factory set at 1/8 inch. If needed, adjust bridge thickness. Do NOT make it too thin.
9. Return the panels to their normal positions and secure them to the machine.
10. Instruct the user in the operation of the machine and its maintenance requirements.
11. Fill out and mail the warranty registration form.

Typical Cycle Times (minutes)

Listed times are for clean machines. Cycle times at startup will be longer until the system stabilizes.

Model	70°F. cond air / 50°F. water	90°F. cond air / 70°F. water
C0522R	12-14	13-15
C0530R	12-14	13-15
C0630R	8-10	9-11
C0830R	10-12	11-13
C1030R	10-12 1	2-14

Adjustments

Bridge Thickness - For the Service Tech Only

1. Push and hold Off till the machine stops.
2. Remove evaporator cover.
3. Remove curtain.
4. Use a hex wrench and rotate the bridge thickness adjustment screw in 1/8 turn increments CW to increase bridge thickness. Rotate CCW to decrease bridge thickness.

Caution: Do not make the bridge too thin or the machine will not harvest properly. Bridge thickness adjustments are not covered by warranty.

5. Return curtain and evaporator cover to their normal positions.
6. Push and release the On button. Check next harvest of ice. Repeat steps 1-6 if needed.

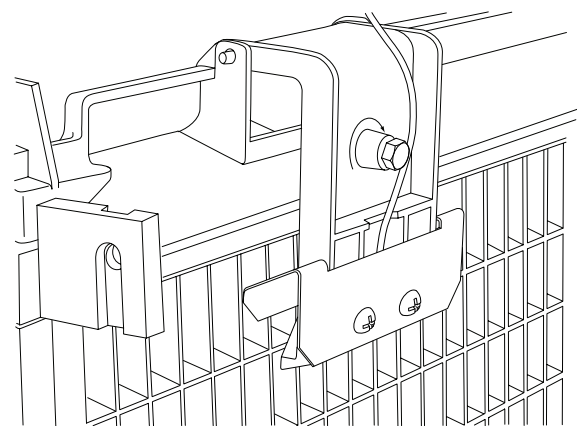
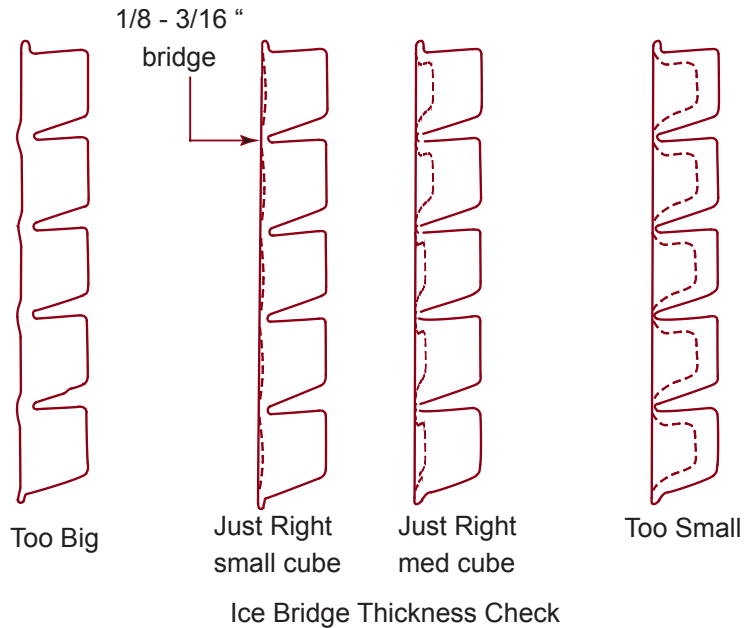

Bridge Thickness Adjustment Mechanism

Water Purge Setting

The water purge is factory set to automatically adjust the amount of water purged per cycle. The setting can be changed to one of 5 manual settings or left on automatic.

Purge setting	1 - Minimum	2 - Moderate	3 - Standard	4 - Heavy	5 - Maximum	A - Automatic
Water Type	RO water or equivalent, TDS less than 35	Low TDS non - RO water	Setting for typical water	High TDS water	Very High TDS water, greater than 256	Factory setting, suitable for any water with conductivity not less than 10 microSiemens/cm.

To set:

1. Switch the machine OFF by holding the Off button in until a number or the letter A shows on the display.
2. Press and release the On button repeatedly until the number on the display corresponds to the desired setting.
3. Press and release the Off switch again to return to the normal control state.

**C0522 through C1030
Remote Condenser Models - User Manual**

Use and Operation

Once started, the ice machine will automatically make ice until the bin or dispenser is full of ice.

When ice level drops, the ice machine will resume making ice.

Caution: Do not place anything on top of the ice machine, including the ice scoop. Debris and moisture from objects on top of the machine can work their way into the cabinet and cause serious damage. Damage caused by foreign material is not covered by warranty.

There are four indicator lights at the front of the machine that provide information on the condition of the machine.

Indicator Lights:

- Power
- Status
- Water
- De-Scale & Sanitize

Note: A Component Indicator Light switches ON to indicate that the component is operating.

Note: There are two Curtain Switch lights, SW1 and SW2. These single plate models have **one curtain switch light on all the time** (either one), as a curtain switch light is ON when a curtain is either open or not present.

	Indicator Lights & Their Meanings			
	Power	Status	Water	De-Scale & Sanitize
Steady Green	Normal	Normal – bin full or making ice	-	-
Blinking Green	Self Test Failure	Switching on or off	-	-
Blinking Red	-	Diagnostic shutdown or, if making ice, temperature sensor failure	Lack of water	-
Yellow	-	-	-	Time to de-scale and sanitize
Blinking Yellow	-	-	-	In Cleaning mode
Light off	No power	Switched off	Normal	Normal
All Blinking	Unit remotely locked out – check with leasing company			

If the Water light is on, the machine has sensed a lack of water. Check the water supply to the machine. The water may have been shut off or the water filter cartridges need to be changed.

If the De-Scale light is on, the machine has determined that it may need to be cleaned. Contact an authorized Scotsman service agent and have the machine cleaned, de-scaled and sanitized.

C0522 through C1030 Remote Condenser Models - User Manual

Control Switches

The On and Off Switches are accessible from the front of the machine.

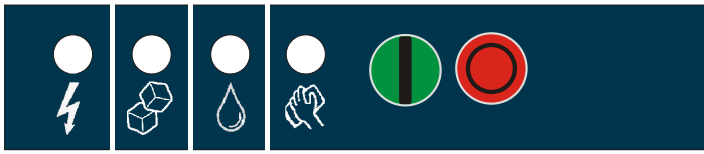

To switch the machine OFF, push and release the Off button. The machine will shut off at the end of the next cycle.

To switch the machine ON, push and release the On button. The machine will go through a start up process and then resume ice making.

Control Options

There are two optional, field installed controls that can be on this machine.

- VariSmart™ adjustable ice level control
- SmartBoard™ advanced control board and data logger

Optional adjustable ice level control (KVS)

When this option is present there is an adjustment post and an additional indicator light to the right of the four indicator lights mentioned above. The ultrasonic ice level control allows the user to control the point that the ice machine will stop making ice before the bin or dispenser is full. Reasons for this include:

- Seasonal changes in ice used
- Planning to sanitize the bin
- Faster turnover for fresher ice
- Certain dispenser applications where maximum ice level is not desired

Use of adjustable ice level control

There are several positions the ice level can be set to, including Off (knob and label indicators lined up), where it fills the bin until the standard bin control shuts the machine off. See the kit's instructions for complete details.

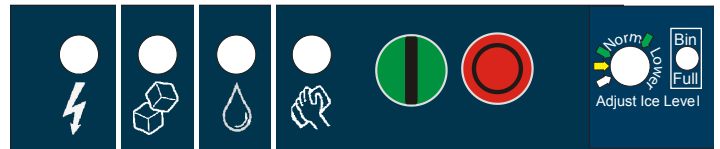

Rotate the adjustment post to the desired ice level.

The machine will fill up to that level and when it shuts off the indicator light next to the adjustment post will be on.

Note: Ice will build up in the bin or dispenser at an angle, the distances listed above will be from the sensor to the top of the ice directly beneath it.

The actual distance between the highest point of the ice may be closer or further away, depending upon the angle of the ice.

Options and Other Information

Optional Advanced Feature Board (KSB)

When this option is present there is an additional display panel in the area below the main control board. It is not visible when the front panel is on.

The Advanced Feature Board's features include:

- Seven day programmable ice level setting when used with the optional Ultrasonic ice level control
- Recording of machine operation, including cycle time.
- Calculation of average cycle time
- Recall of malfunctions with the time they occurred.

Ice

The cuber drops ice in large sections. That ice will break up into random parts as it falls into the bin, but some large sections may remain on top of the ice in the bin. When removing ice, tap the groups of ice with an ice scoop to separate them into smaller units. In a dispenser, this ice will break up into mostly individual cubes as the dispense mechanism moves the ice.

Heat

Most heat is exhausted at the remote condenser. The ice machine should not generate significant heat.

Noise

The ice machine will make noise when it is in ice making mode. The compressor and water pump all produce some sound. It is also normal to hear some cracking just before the harvest cycle begins.

In addition, during the harvest cycle the harvest assist solenoid will click twice as it pushes the ice out and returns to its normal position. The ice harvests as a unit or slab, which makes some noise when it impacts the bin or dispenser. These noises are all normal for this machine.

C0522 through C1030 Remote Condenser Models - User Manual

Cleaning, Sanitation and Maintenance

This ice system requires three types of maintenance:

- Remove the build up of mineral scale from the ice machine's water system and sensors.
- Sanitize the ice machine's water system and the ice storage bin or dispenser.
- Clean the remote condenser.

It is the User's responsibility to keep the ice machine and ice storage bin in a sanitary condition. Without human intervention, sanitation will not be maintained. Ice machines also require occasional cleaning of their water systems with a specifically designed chemical. This chemical dissolves mineral build up that forms during the ice making process.



Sanitize the ice storage bin as frequently as local health codes require, and every time the ice machine is cleaned and sanitized.

The ice machine's water system should be cleaned and sanitized a minimum of twice per year.

1. Remove the front panel.
2. Remove the evaporator cover.
3. If the machine is operating, push and release the Harvest button. When the machine completes the Harvest cycle it will stop. If the bin is full (b shows in display) push and release the Off button.
4. Remove all ice from the storage bin or dispenser.
5. Push and release the Clean button. The yellow Clean light will blink and the display will show C. The machine will drain the reservoir and refill it. Go onto the next step when the purge valve light has gone out or the reservoir has filled.
6. Pour 8 ounces of Scotsman Clear 1 ice machine scale remover into the reservoir.
7. Allow the ice machine scale remover to circulate in the water system for at least 10 minutes.
8. Push and release the Clean button again. The yellow Clean light will be on continuously and the machine will drain and refill the reservoir to flush out the ice machine scale remover and residue.
9. Allow the drain and refill process to continue for at least 20 minutes.
10. Push and release the Off button. The clean cycle will stop and the display will show O.

Note: if the machine has not been de-scaled for an extended period of time and has significant mineral scale remaining, repeat steps 5-10.

11. Mix a cleaning solution of 1 oz of ice machine scale remover to 12 ounces of water.
12. Locate curtain, push in on edge of curtain by pivot pin to release it. Pull each curtain out of machine.

 CAUTION	Ice machine cleaner contains acids. Acids can cause burns.
	If concentrated cleaner comes in contact with skin, flush with water. If swallowed, do NOT induce vomiting. Give large amounts of water or milk. Call Physician immediately. Keep out of the reach of children.

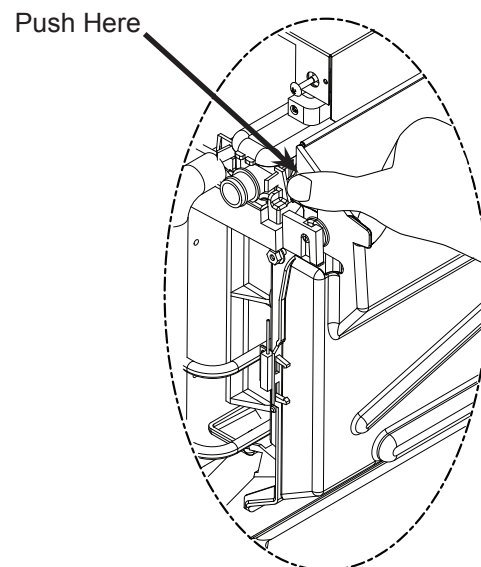

7. Allow the ice machine scale remover to circulate in the water system for at least 10 minutes.

C0522 through C1030 Remote Condenser Models - User Manual

13. Remove water distributors from ice machine.
Inspect distributor for restricted orifice holes. Be sure all holes are full open.

Squeeze Tabs Together, Slide Out Until it Stops
Then Lift to Remove

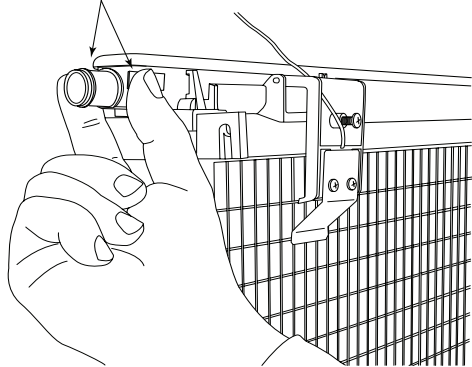

Remove and Inspect Water Distributor

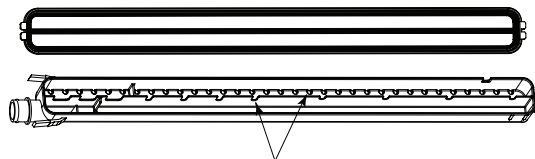

Inspect Orifice Holes

14. Locate ice thickness sensor. Squeeze mounting legs together to release sensor. Wash the metal surfaces of the sensor and the adjustment screw with ice machine scale remover solution. Also wash the water distributor and curtain with the ice machine scale remover solution.
15. Locate water level sensor. Squeeze catches together and pull up to remove sensor. Wash metal surfaces of sensor with ice machine scale remover solution.

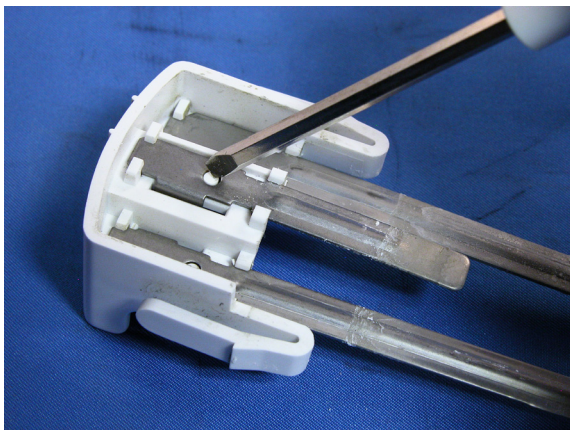

Release probes by pushing in on white buttons and pulling probe down out of holder.

16. Mix a solution of sanitizer.

Note: A possible sanitizing solution may be made by mixing 1 packed of Stera Sheen Green Label sanitizer (available from Scotsman) with 2 gallons of warm (95-115°F.) potable water.

17. Thoroughly wash all surfaces of the ice thickness sensor, water level sensor, curtain and water distributor with the sanitizer solution.
18. Wash all interior surfaces of the freezing compartment, including evaporator cover and right side panel liner with the sanitizer solution.
19. Return water level sensor, ice thickness sensor, water distributors and curtains to their normal positions.
20. Push and hold the clean button to drain the reservoir. Push and release the clean button again and when the purge valve indicator light goes out, immediately pour the remaining cleaning solution into the reservoir.
21. Circulate the sanitizer solution for 10 minutes, then push and release the Clean button.
22. Allow the water system to be flushed of sanitizer for at least 20 minutes, then push and release the Off button.
23. Return the evaporator cover and front panel to their normal position and secure with the original fasteners.
24. Push and release the On button to resume ice making.

Ice Storage Bin

1. Remove and discard all ice.
2. Mix a solution of 7 ounces Scotsman Clear 1 ice machine scale remover to 84 ounces of potable water and wash all interior surfaces of the ice storage bin to remove any mineral scale build up. Pour excess cleaner solution into the bin's drain.
3. Mix a solution of sanitizer and thoroughly wash all interior surfaces of the ice storage bin. Pour excess sanitizer solution into the bin's drain

C0522 through C1030 Remote Condenser Models - User Manual

Remote condenser

The condenser fins will need to be cleaned.

Push and release the Off button. Wait until the machine stops.

Note: Lock out the controller or the ice machine power supply to prevent an unauthorized fan motor restart.

If there is imbedded grease, use a commercial coil cleaner to wash out the grease. Dust can be blown out with compressed air from the inside or use a vacuum cleaner and soft brush. Be careful not to damage the condenser's fins. Use a fin comb to straighten any bent fins.

Exterior Panels

Fingerprints, dust and grease will require cleaning with a good quality stainless steel cleaner.

Water filters

If the machine has been connected to water filters, check the cartridges for the date they were replaced or for the pressure on the gauge. Change cartridges if they've been installed more than 6 months or if the pressure drops too much when the ice machine fills with water

C0522 through C1030 Remote Condenser Models - User Manual

What to do before calling for service

Reasons the machine might shut itself off:

- Lack of water.
- Freeze cycle takes too long.
- Harvest cycle takes too long.
- High discharge temperature.
- Controller self test failure.

Check the following:

1. Has the water supply to the ice machine or building been shut off? If yes, the ice machine will automatically restart within 25 minutes after water begins to flow to it.
2. Has power been shut off to the ice machine? If yes, the ice machine will automatically restart when power is restored.
3. Has someone shut the power off to the remote condenser while the ice machine still had power? If yes, the ice machine may need to be manually reset.
4. Is the curtain open because some ice is stuck under it? If so, remove the ice and the machine should start in a few minutes.

Note: Curtain can be removed & replaced anytime the machine is in a standby mode or when it is in a freeze cycle. However, removal of the curtain during freeze will result in water flowing into the bin. Removal of the curtain during harvest terminates harvest at that point and, if left off, will result in the machine shutting off.

To Manually Reset the machine.

- Push and release the Off button.
- Push and release the On button.

To Shut the Machine Off:

1. Push and hold the Off button for 3 seconds or until the machine stops.

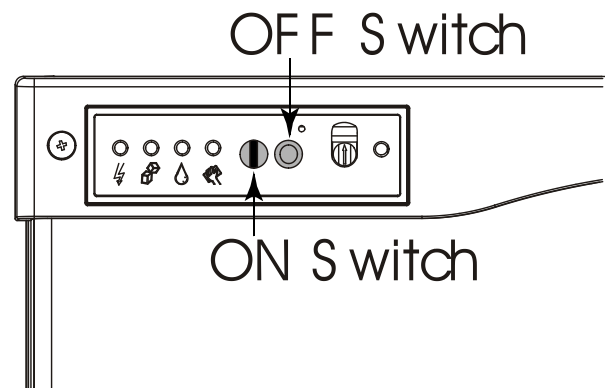
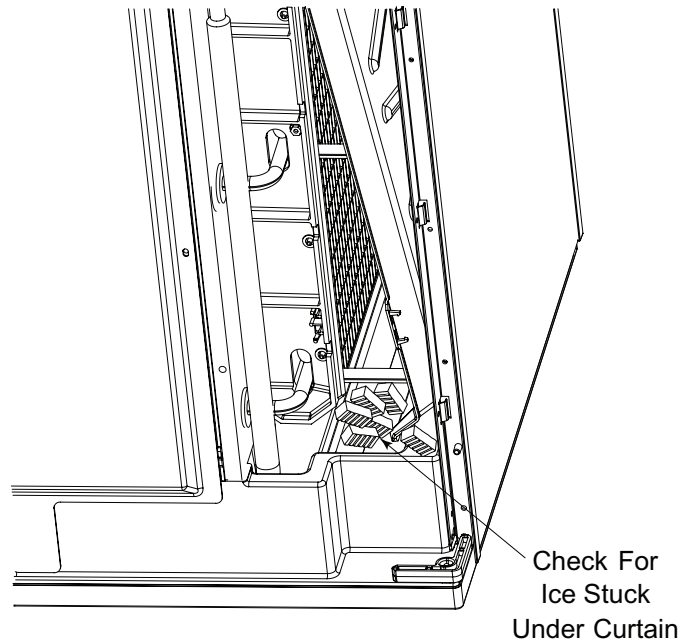

SCOTSMAN ICE SYSTEMS

775 Corporate Woods Parkway

Vernon Hills, IL 60061

800-726-8762

www.scotsman-ice.com