



# Prodigy Cuber and Flaker Technical Training

# Presentation Topics

- Cuber

- Overview
- Installation
  - Cuber and Flaker
- Operation
- Diagnosis
- Service

- Flaker

- Operation
- Diagnosis
- Service



# Cuber Overview

- Modular cubers
  - Air cooled, water cooled, remote air cooled
    - Remote low side in separate presentation
- 22", 30" and 48" wide platforms
  - 22 and 30 inch platforms have 1 evaporator
  - 48 inch platforms have 2 evaporators
  - C2648 has 3 evaporators
- Common look and operation across models
- Front service access to most components

## C2648 Remote Cuber

- Remote only
- Three phase only
- 3 plates & 3 curtain switches
- 2 pumps
- Larger cabinet – 28.25” deep
- OPR/CPR valve
- New condenser – PRC241
- Larger diameter line set
- For Upright Bins only

# CB Models – Advanced Sustainability

- New in 2011, air cooled only, models are: CB0522, CB0330, CB0530, CB0630, CB0830 and CB1030
- Fully Featured, includes all standard Prodigy features plus:
  - Ultrasonic ice level control
  - Information display / data logger



# Installation

## Installation – All Models

- Set the machine in place
- Remove any packing
- Level the cabinet
- Connect drain (s)
- Connect water supply
- Remotes: Route and connect tubing to condenser
- Add any optional accessories
  - Smart Board, Vari Smart, Air Baffle, Front Air In
- Connect power

## Installation – Air Cooled

- Potable water connects to 3/8 fitting on back of cabinet
  - Cuber fitting is 3/8" female pipe thread – direct connection to inlet water solenoid valve
    - Flaker has 3/8 male flare connection
- Reservoir or condensate pan drain fitting is 3/4" female pipe thread
  - Vent for proper draining
  - Minimum slope of 1/4" fall per foot of horizontal run





## Installation – Water Cooled

- Same as air cooled plus an inlet and drain for the water cooled condenser
  - Water cooled inlet should not be filtered
  - Water cooled drain tube should not be vented

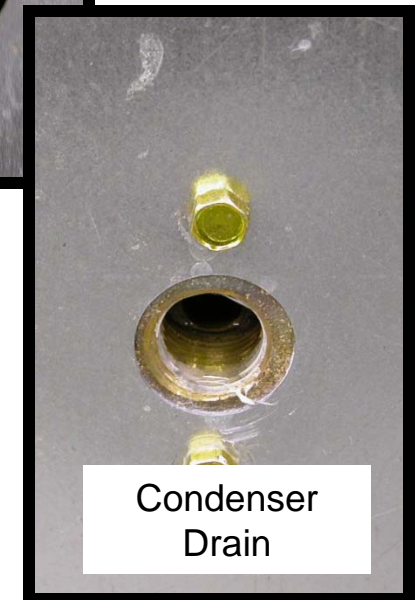

# C2648: Water and Drain

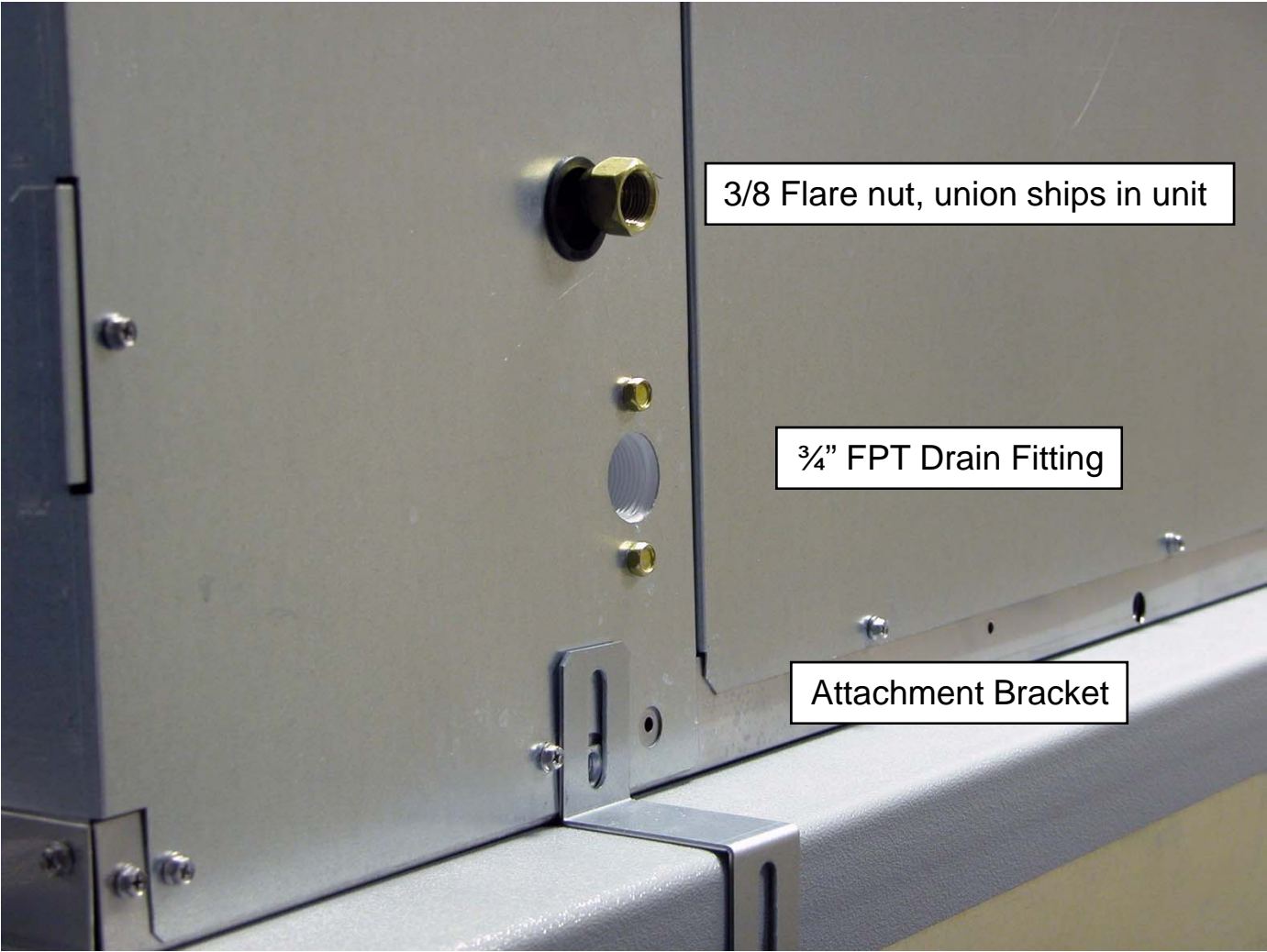

## Installation – Remote Air Cooled

- **MUST** use condensers with headmaster in them:
  - ERC111, ERC311 and ERC611
  - C2648 uses PRC241
  - Line sets – 10, 25, 40, or 75 foot lengths
  - Power supplied by ice machine for fan motor



ERC311



PRC241

## Installation – C2648

- Upright bins recommended
  - Ships with brackets to attach to BH1100/1300/1600
- Must use PRC241 remote condenser and RTEL line set

# C2648 Condenser and Line Sets

5/8 inch discharge  
1/2 inch liquid

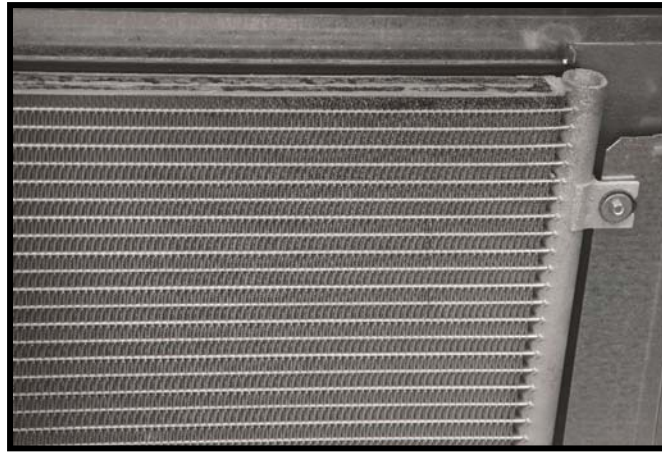

Aluminum Coil

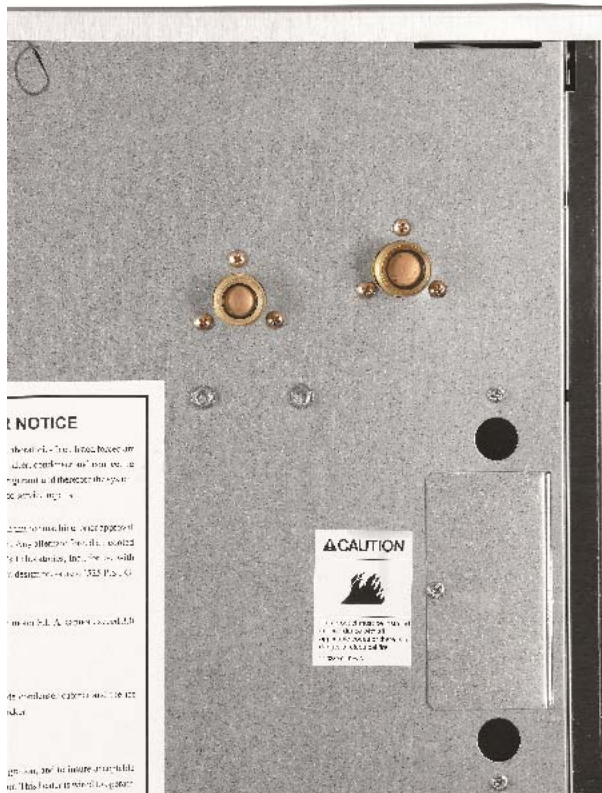

# Remote Installation

- Typical Installation
  - Condenser above ice machine
  - Precharged line set coiled within building
    - Use horizontal coil
    - **NEVER** leave excess coiled up on the roof!

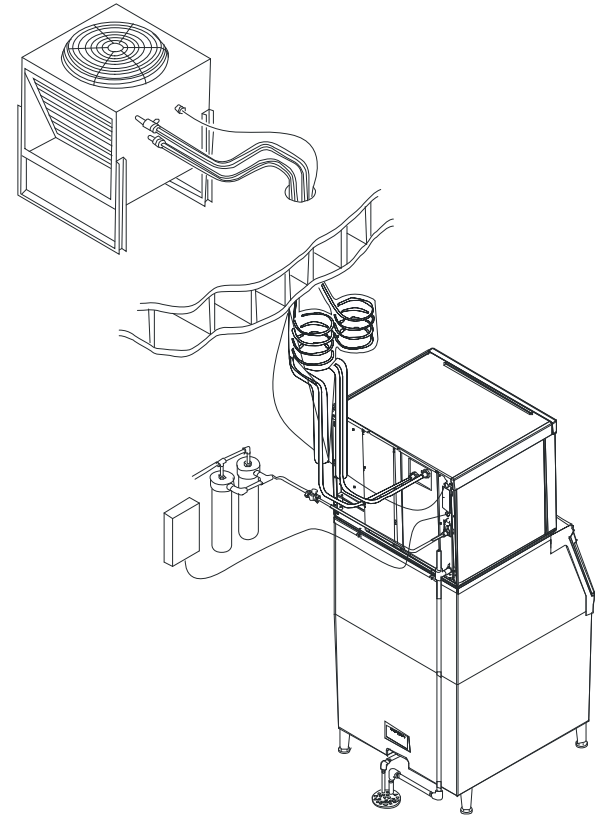

# Remote Installation

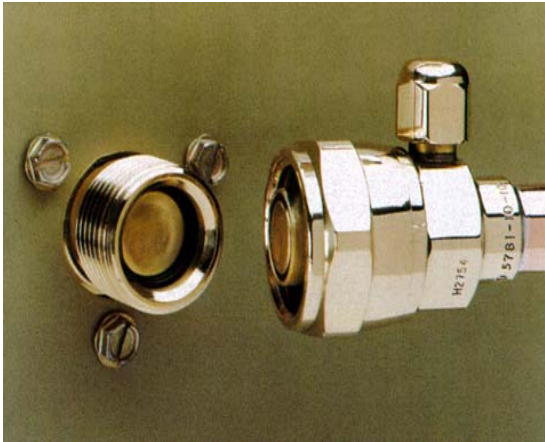

Clean and **Lubricate**  
Quick Connect  
Couplings



Use Two  
Wrenches to  
Tighten



Rotate Swivel Nut **One  
Quarter Turn** More After  
Nut Becomes Tight



Incomplete  
Assembly:  
One  
Thread  
Showing



## Quick Connect Joint

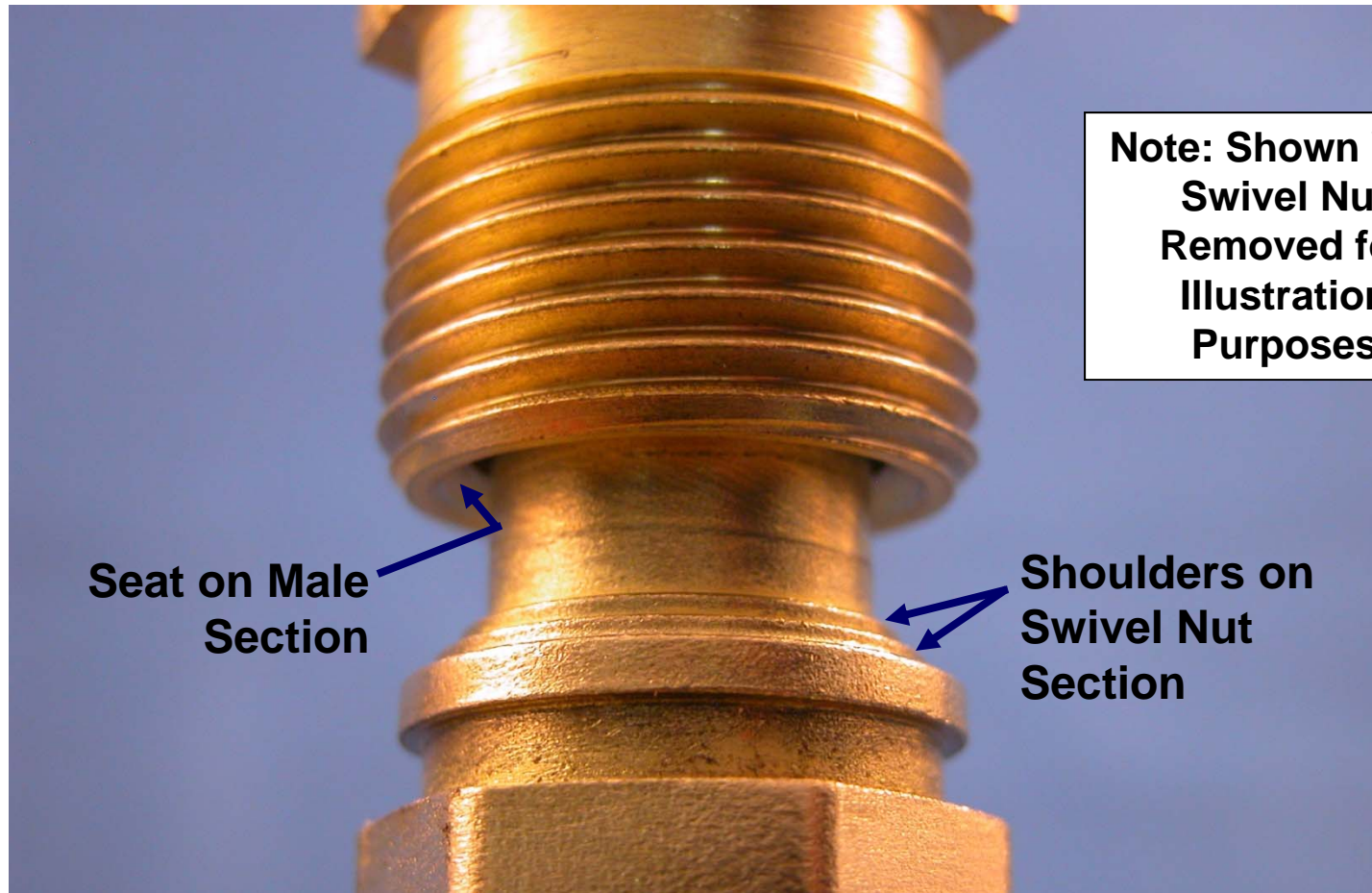

**Note: Shown With  
Swivel Nut  
Removed for  
Illustration  
Purposes**

**Seat on Male  
Section**

**Shoulders on  
Swivel Nut  
Section**

**At final  $\frac{1}{4}$  turn, the shoulders of the swivel nut section are forced into the seat area of the male section, forming the grooves that make the seal**



# Coupling Sealing



Before

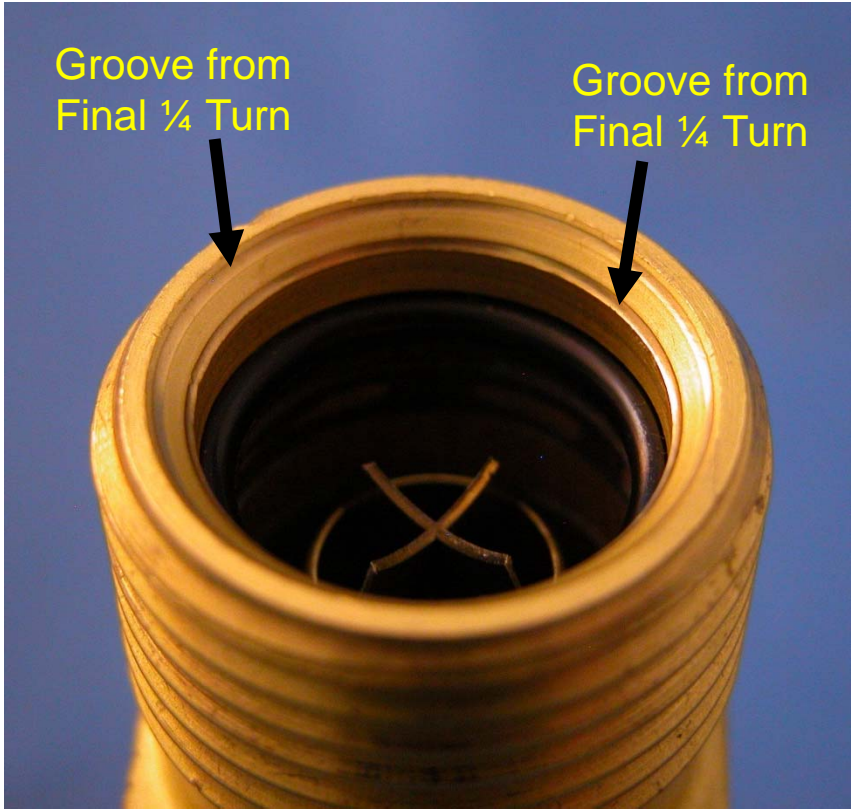

After

# Condenser Rack Applications

- Application must be approved for warranty coverage
  - Bohn and Master Bilt are approved for cubers
- Must add headmaster
  - Bohn and Master Bilt use kit RCKCME6GX
  - Coils may contain air, nitrogen or R-404A refrigerant.
  - Check for refrigerant, if none, purge, evacuate and add R-404A to positive pressure before connecting headmaster kit.

# Cuber Operation

# Cuber Components

- **Electrical**

- PTCR for single phase compressor starting
- Harvest assist solenoid
- Fan motor – air cooled and remote air cooled
- Fan cycling pressure switch for self contained air cooled

- **Control System**

- 12 volt transformer
- Electronic controller
  - Operates all loads

- **Sensors**

- Water level sensor
- Ice thickness sensor
- Curtain switch
- Fan pressure switch
- Water temperature sensor
- Discharge temperature sensor
- High pressure cut out on some models

# Component Location – 30” wide models

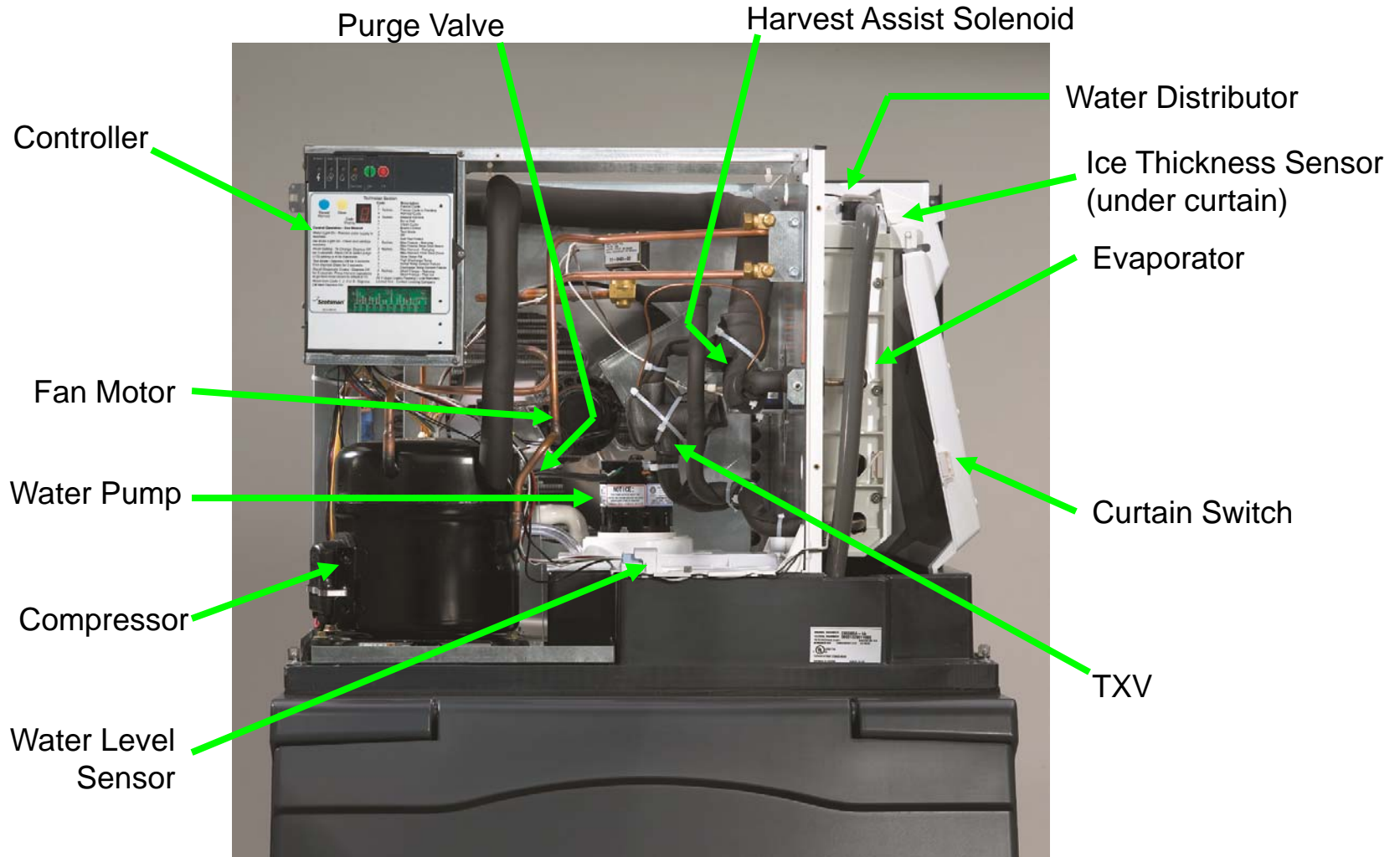

# Component Location – 48” wide models

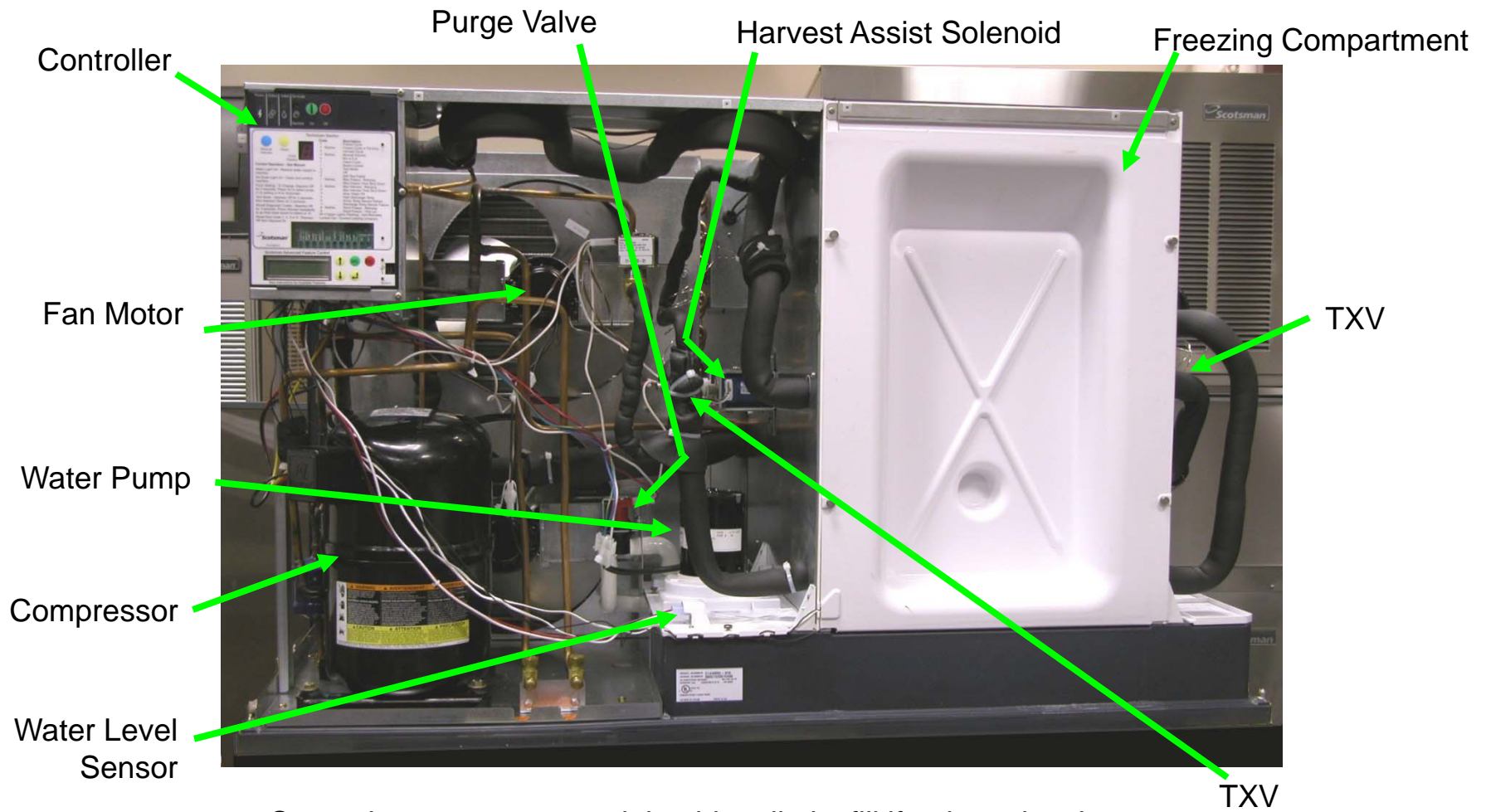

Second water sensor on right side – limits fill if unit not level.

# Component Location – C2648

Two Evaporator Freezing Compartment

Single Evaporator Freezing Compartment

Water Pumps, TXVs, Hot Gas Valves Harvest Assist Solenoids, Inlet Water Solenoid, Water Level Sensor Purge Valve,

Sump Cover over Removable Sump

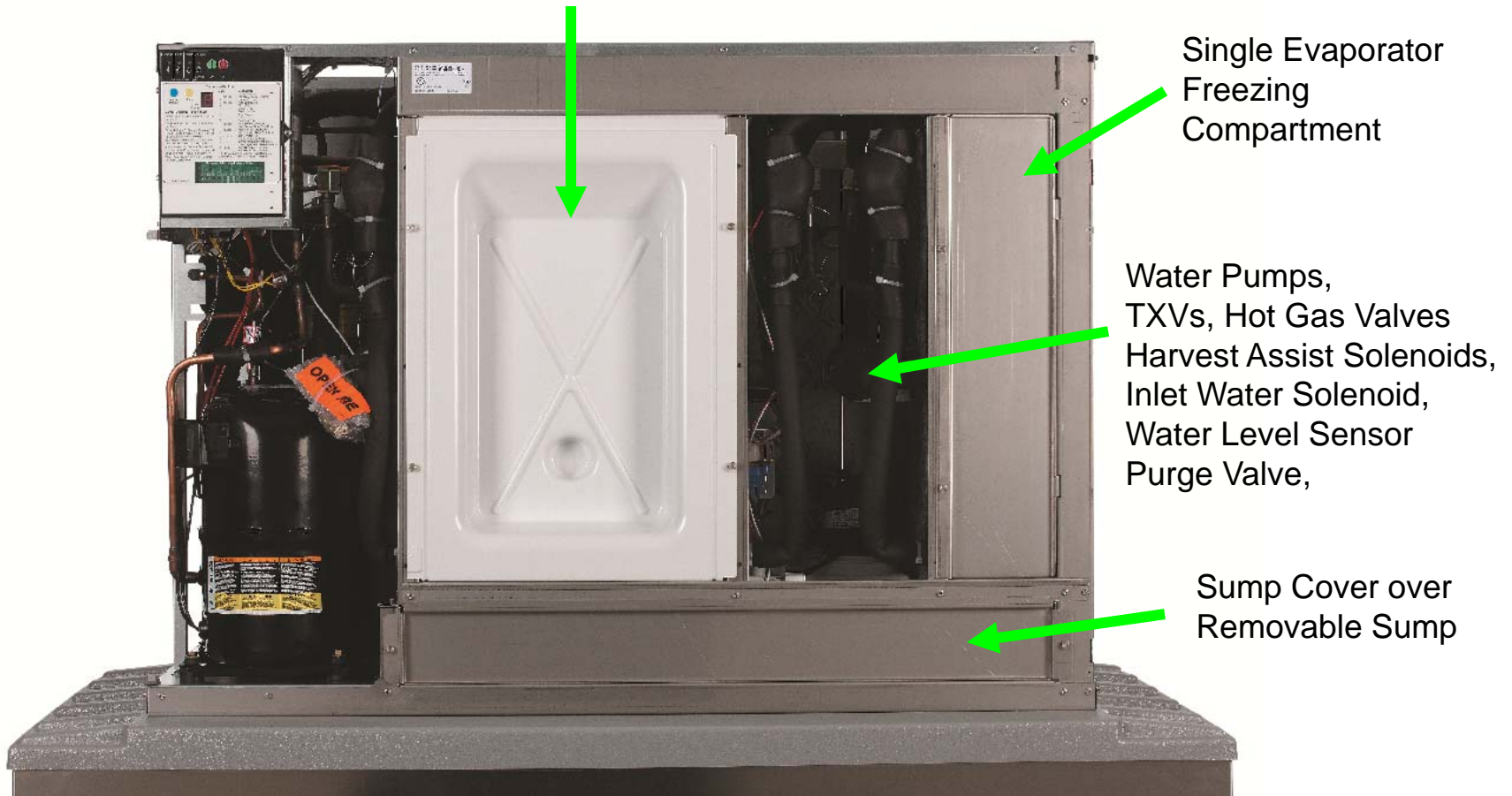

# 48" Models – Freezing Compartment

Water Distributor

Ice Thickness Sensor (under curtain)

Evaporator

Curtain Switch

Curtain Switch

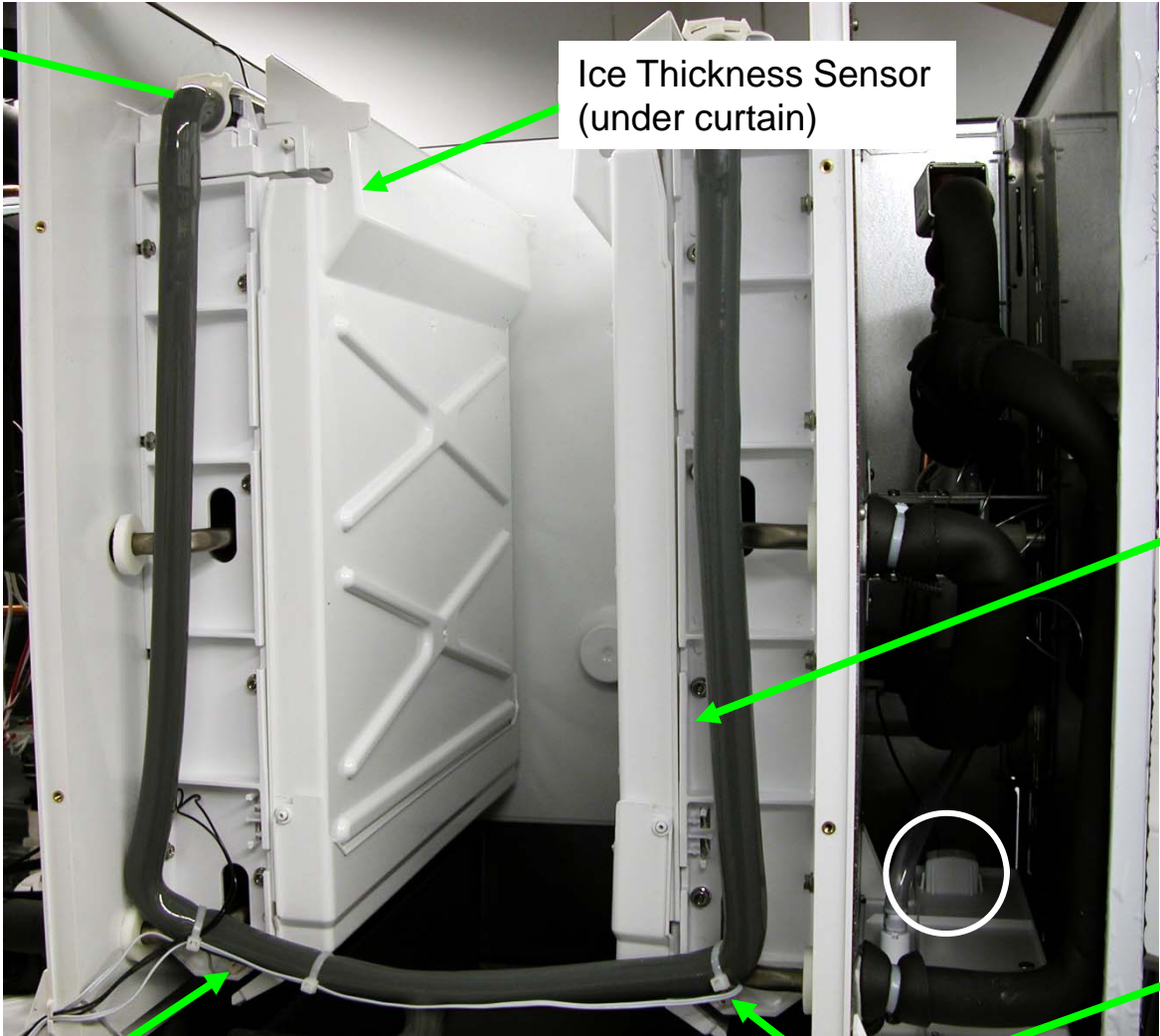



# Component Location – C2648

Ice Thickness Sensor

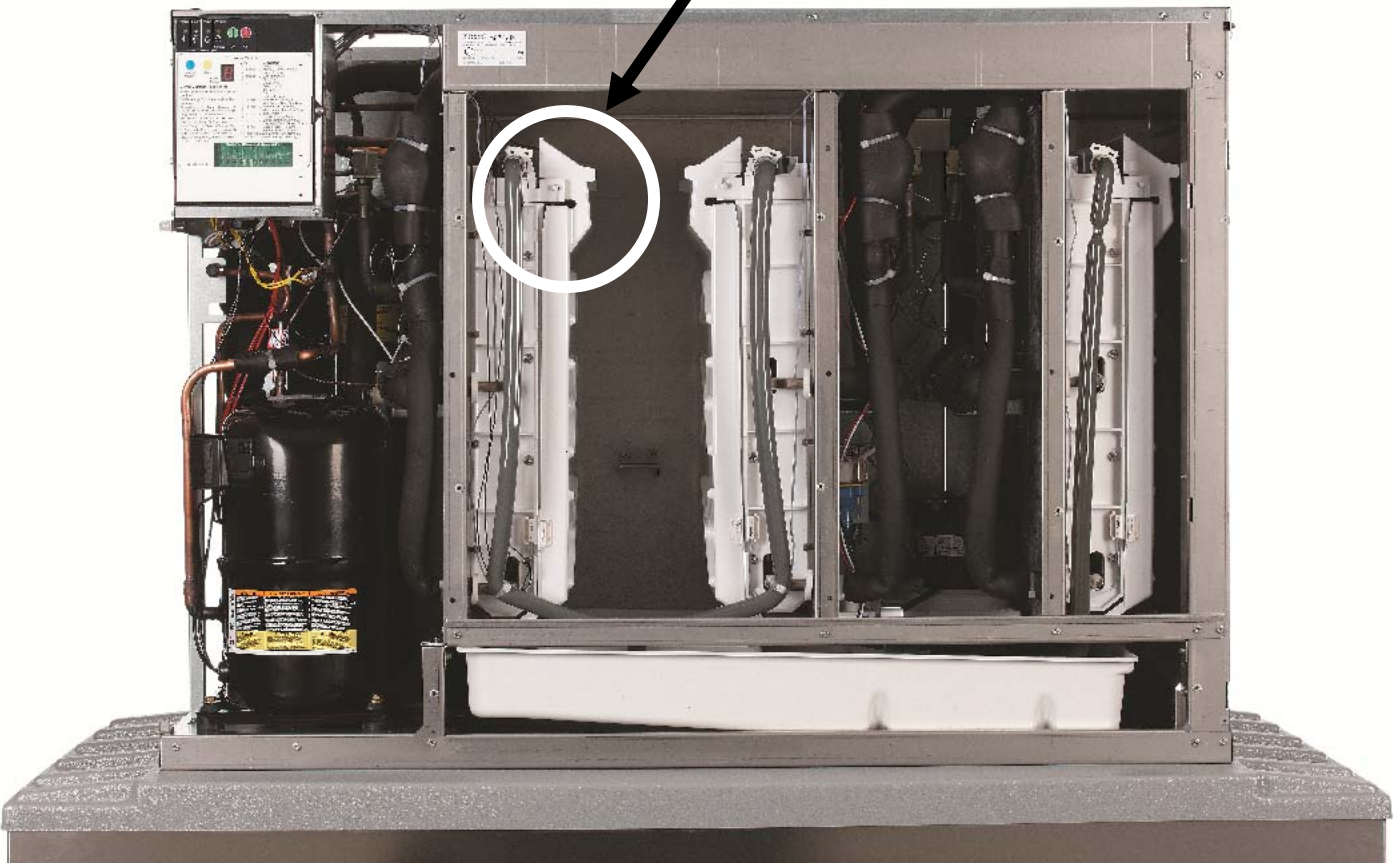

# Prodigy Operation

- Electrical Sequence

- Power up, controller does self check
- Power Light glows Green
- Push and release the green ON button to start the unit



## Cuber Start Up – Air and Water Cooled

- Reservoir emptied and refilled
  - Purge valve opens, water pump starts
  - Hot gas and harvest assist solenoid activate
  - Inlet water valve opens, water fills the reservoir
  - Purge valve closes, pump shuts off
- When the reservoir is full, the water stops and the compressor and pump start
  - Fan motor will start when discharge pressure increases to cut in point of fan cycle switch

## Start Up - Remote

- 4 hour compressor soak out before operation
- Open receiver outlet valve
- Push and release ON switch
  - Purge valve opens, water pump starts
  - Hot gas and harvest assist solenoid activate
  - Inlet water valve opens, water fills the reservoir
  - Purge valve closes, pump shuts off
  - When the reservoir is full, the water stops, the liquid line valve opens and the compressor and pump start

# Water Control – All Cuber Models

- Water Level Sensor
  - Conductivity Probe
  - Water fills when mid-length probe is not touching water
  - Water stops filling when short probe touches water
    - Snaps out of reservoir cover for ease of maintenance

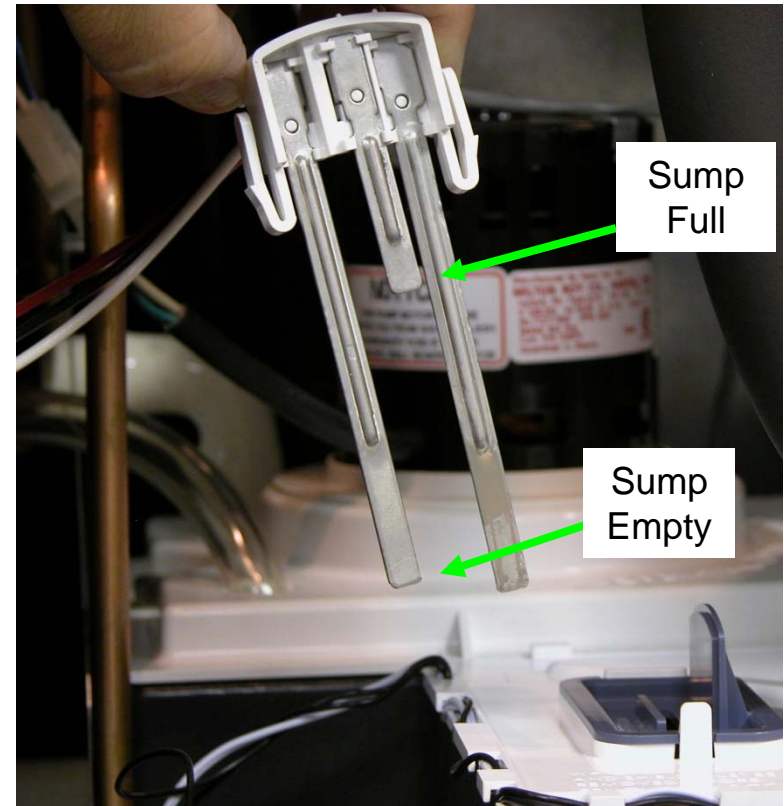

## C2648 Water Level Sensor

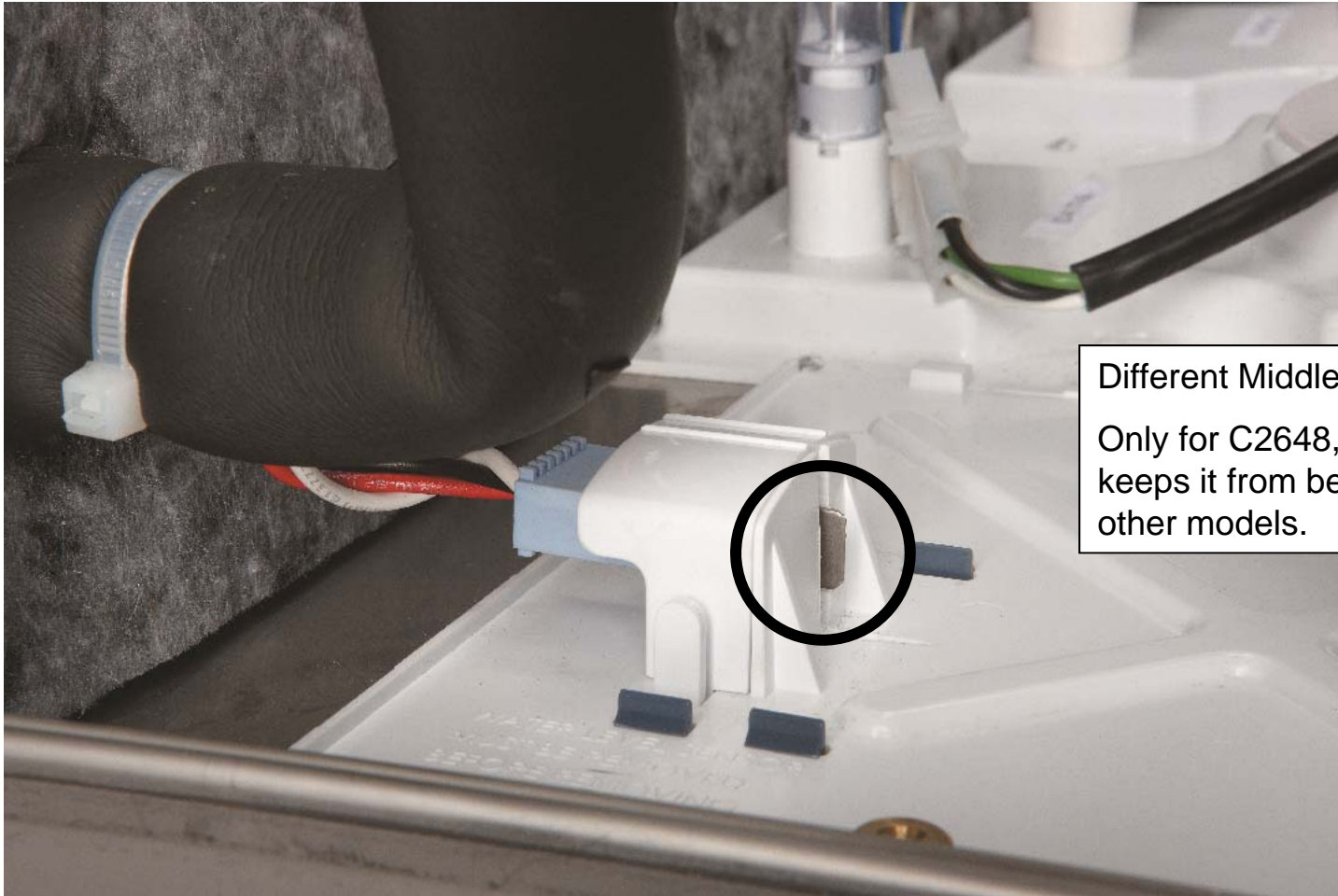

Different Middle Probe.

Only for C2648, metal tab keeps it from being used on other models.

## Freeze Cycle

- Hot gas valve closes and harvest assist solenoid pin retracts after 5 seconds of freeze.
  - Allows compressor to start with minimal discharge pressure
- Freeze continues until reservoir temp falls to preset point, then pump stops for 30 seconds.
  - The dry freeze is an anti-slush process

## End of Freeze Cycle

- Freeze continues until ice thickness sensor is contacted by water for a few seconds, that triggers harvest
- Air cooled fan may shut down a few seconds before harvest to build up heat

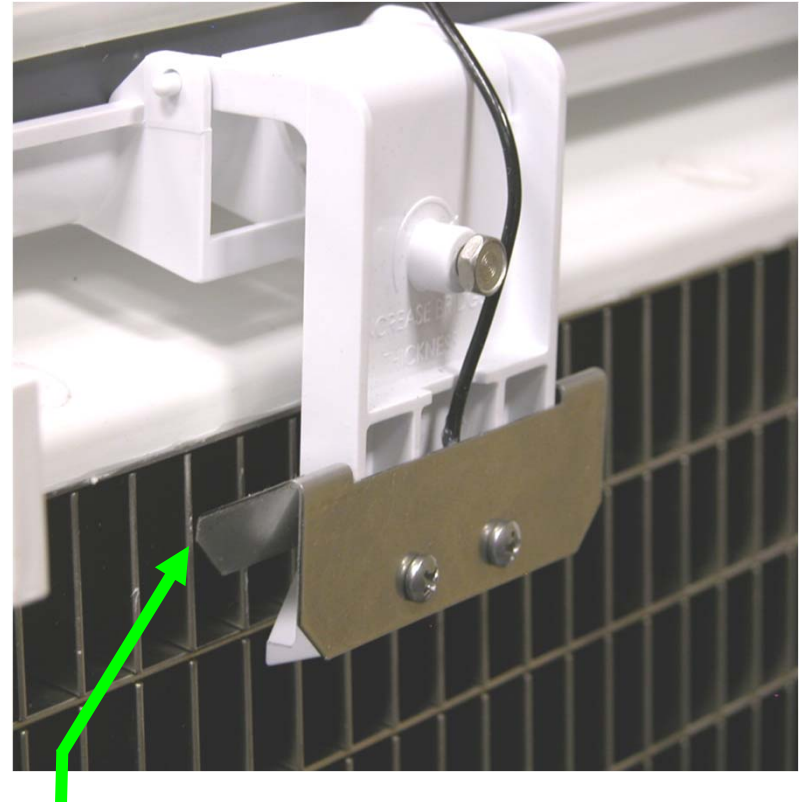

Ice Thickness Sensor

Contact with water makes circuit from controller to cabinet, terminating freeze



# Harvest Cycle

- Air cooled fan motor shuts off
- Harvest assist and hot gas valve solenoids are energized
  - Harvest assist pin will push but not move until ice releases
- Water purges
  - Time varies by water conditions
- Pump shuts off
- Water refills reservoir

## Harvest Assist Solenoid

- Harvest continues until the evaporator heats up enough to release the ice, the harvest assist solenoid pin will extend fully and the ice will release as a unit, forcing the curtain open

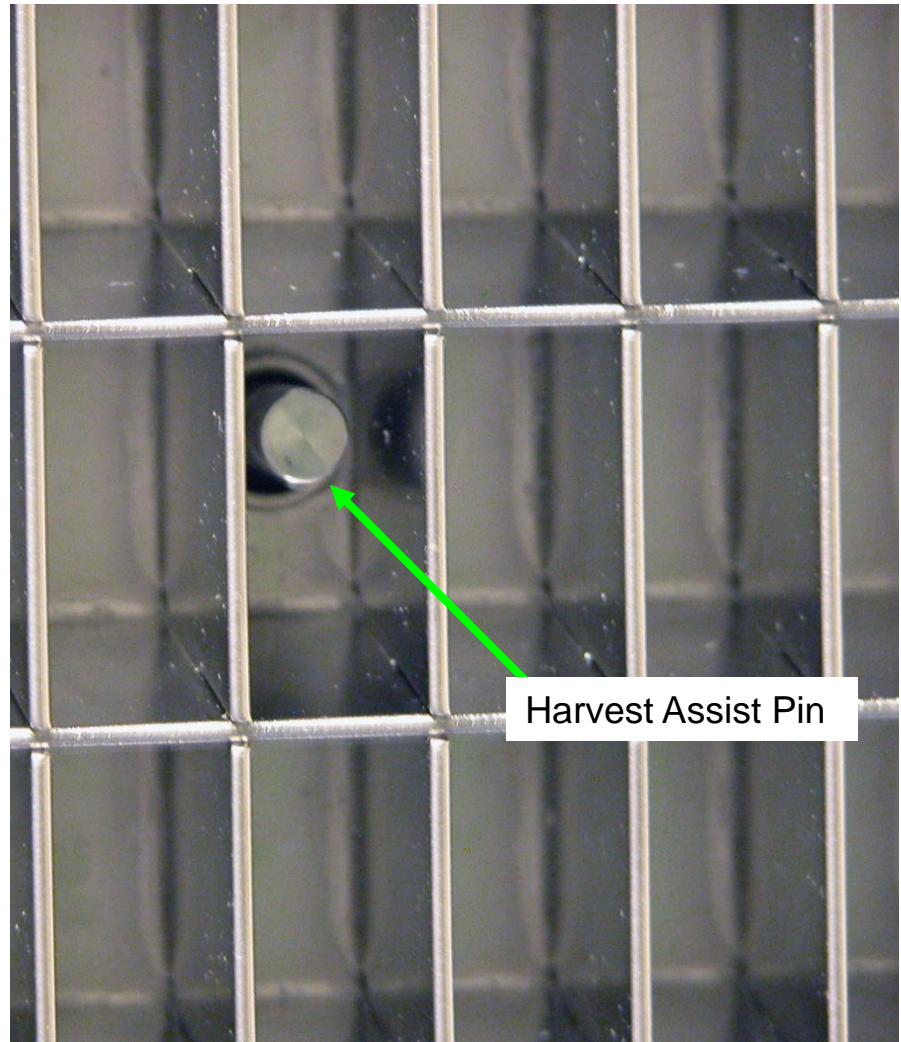

# Curtain Switch

- The curtain switch opening terminates harvest.
  - Stays open = shuts off. If it closes again, a new freeze cycle begins.
  - Switch is the magnetic reed type

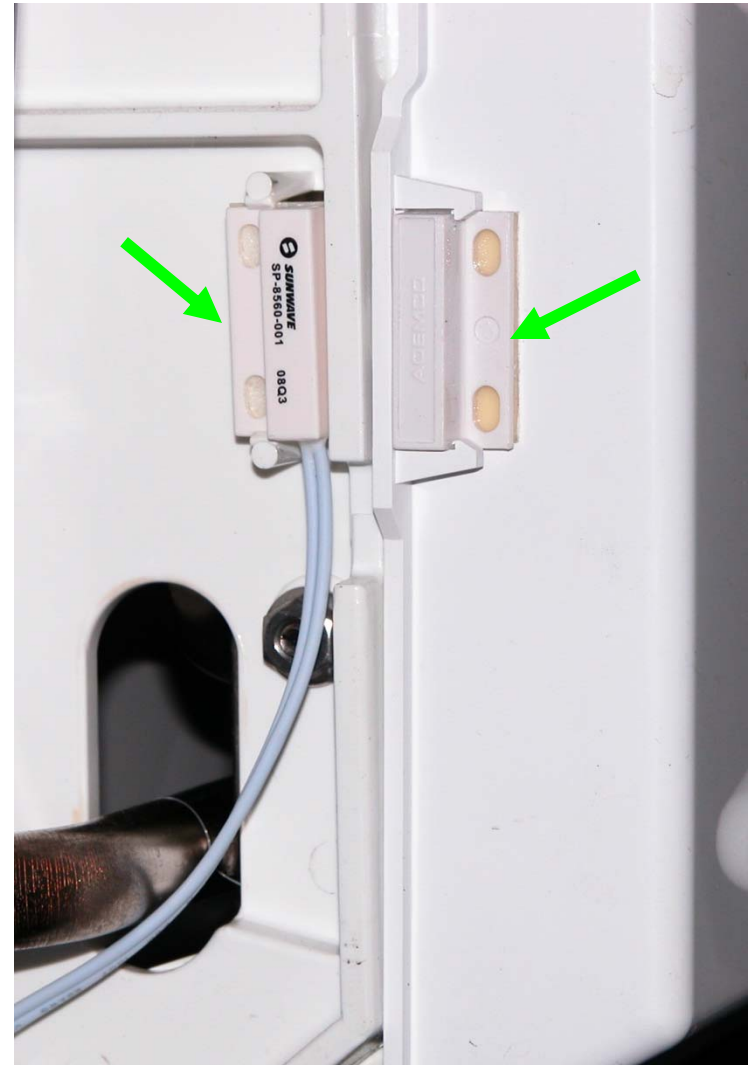

# C2648 Curtain Switches

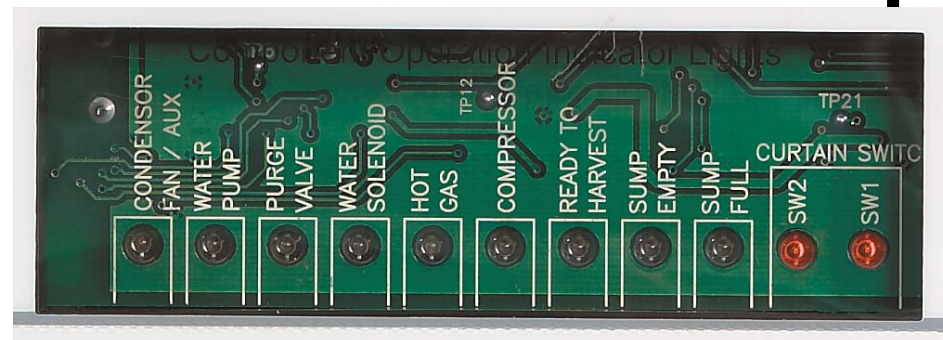
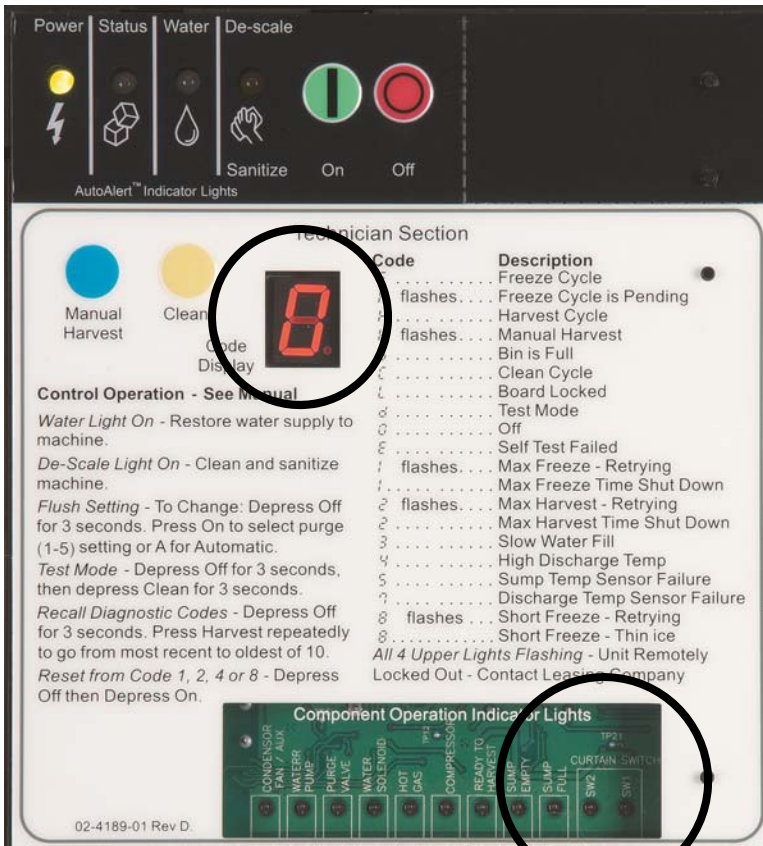

Curtain Switch Indicator Lights  
 2 are on the normal panel  
 1 is the period in the display code

## C2648 Third Switch Connection

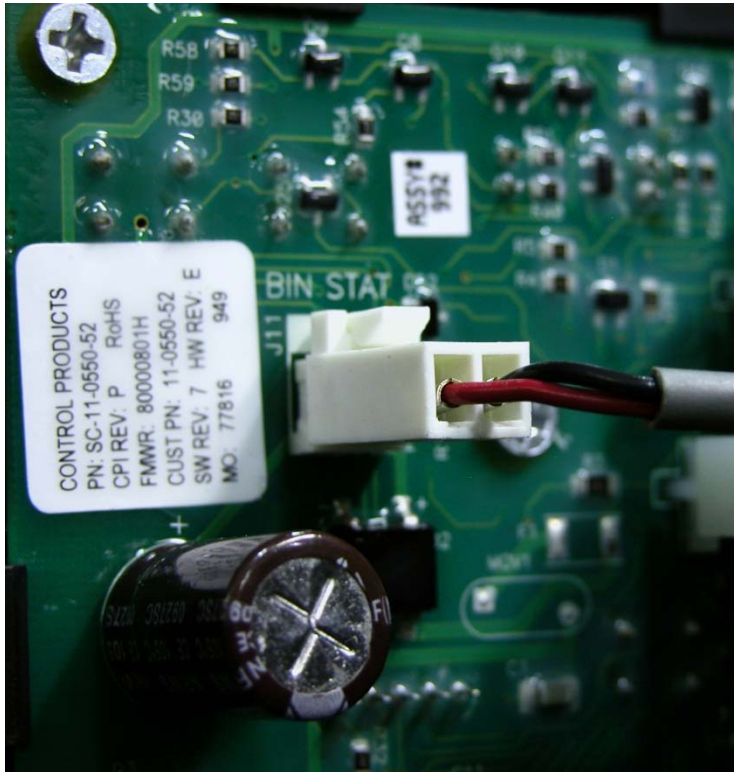

Connects to the Bin Stat  
Terminals. A Bin Thermostat  
cannot be used on this model.

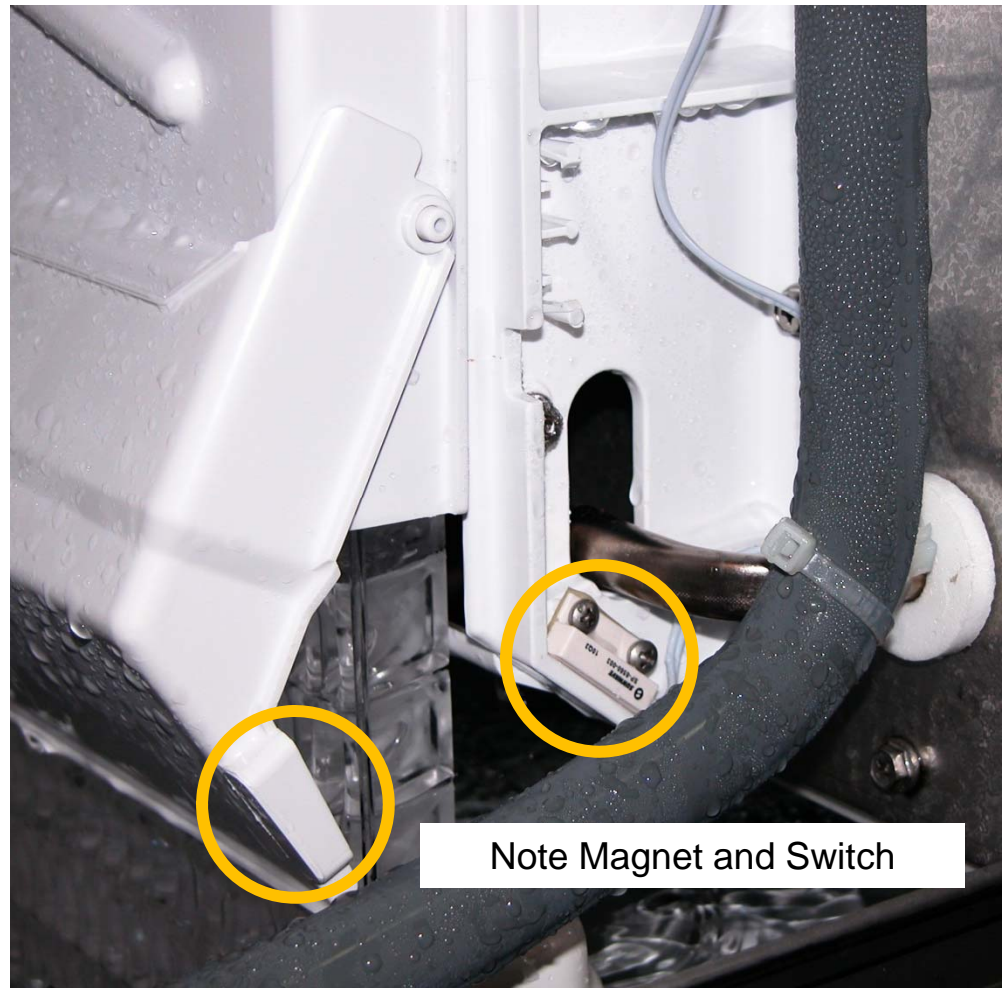

Note Magnet and Switch

# Ice Bridge

1/8" Bridge

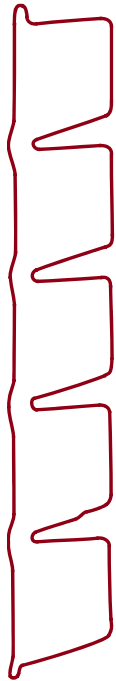

Too Big

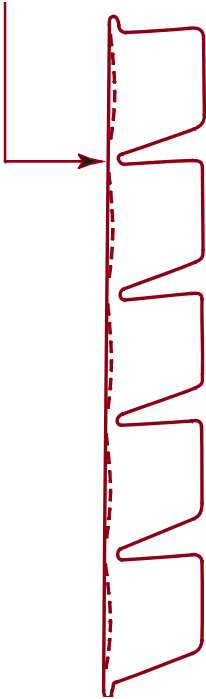

Just Right,  
most models



Just Right,  
Medium cube,  
C0322 and  
C0330



Too Small

# Total Cycle Times

Minutes

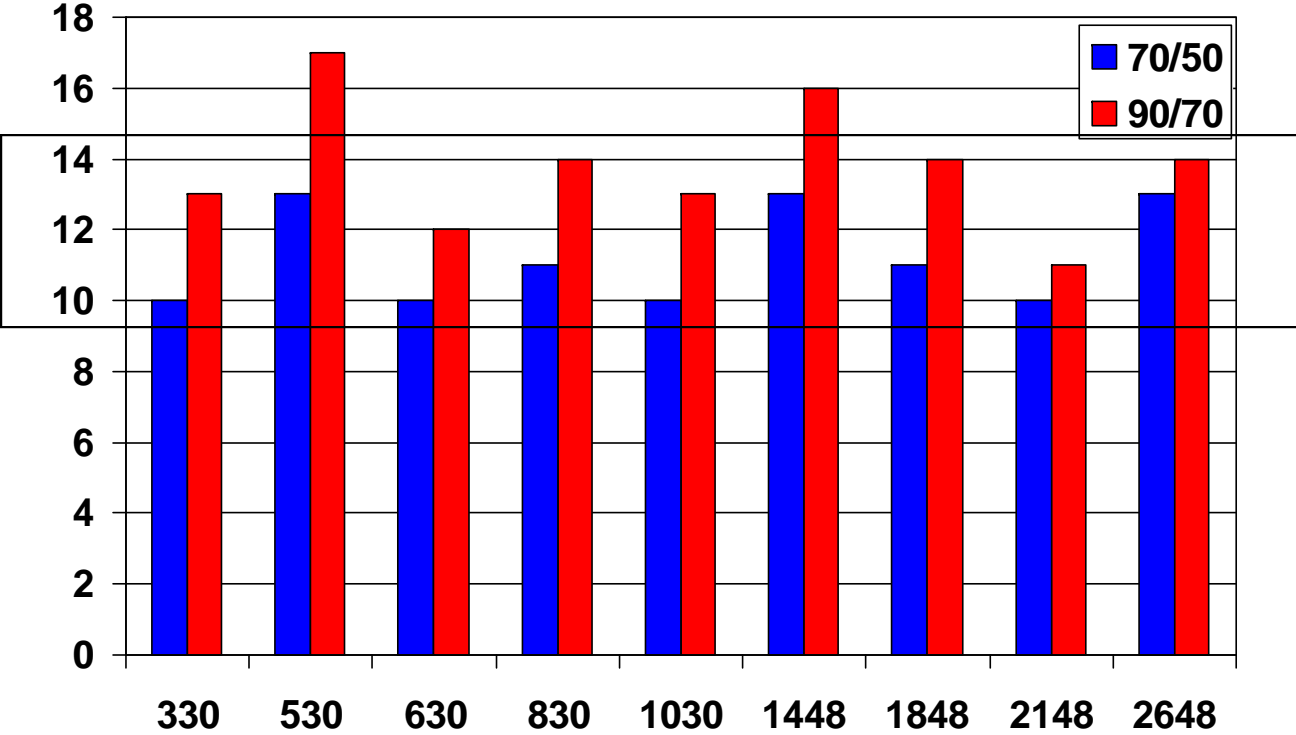

# Harvest Cycle Times (seconds)

Seconds

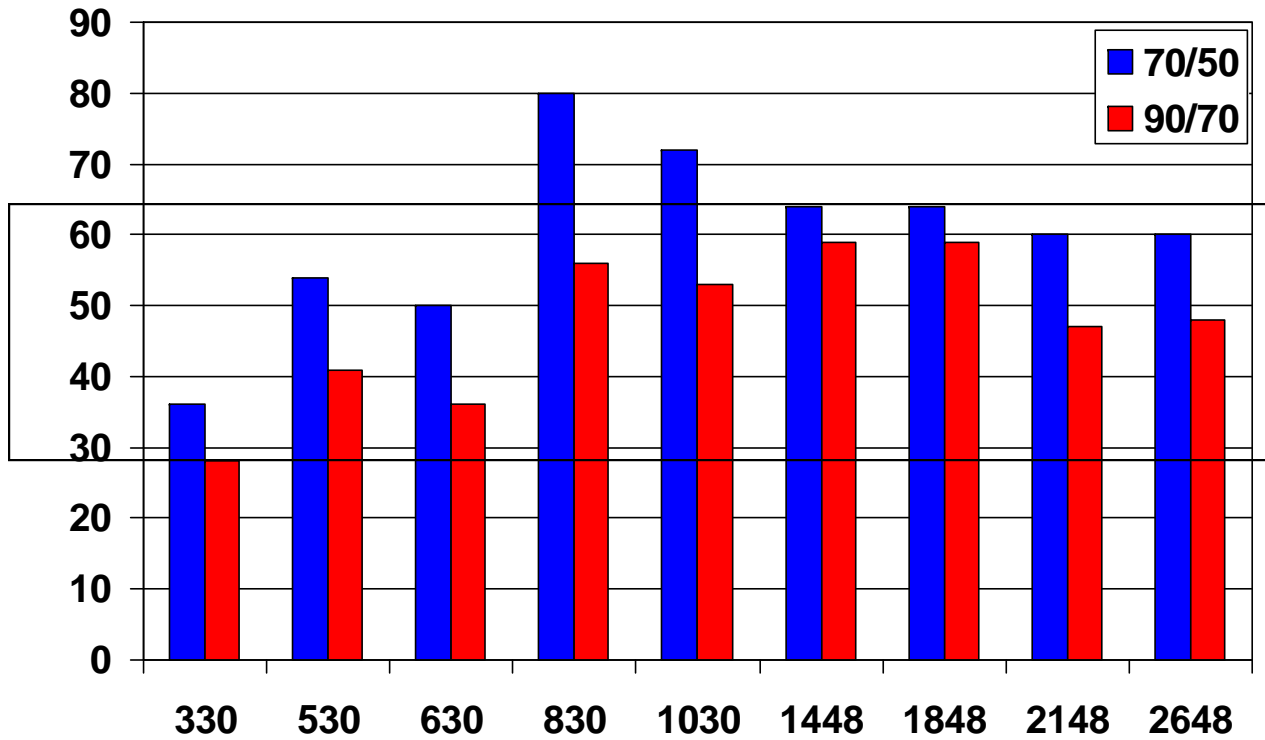



# Suction Pressures, End of Freeze

PSIG

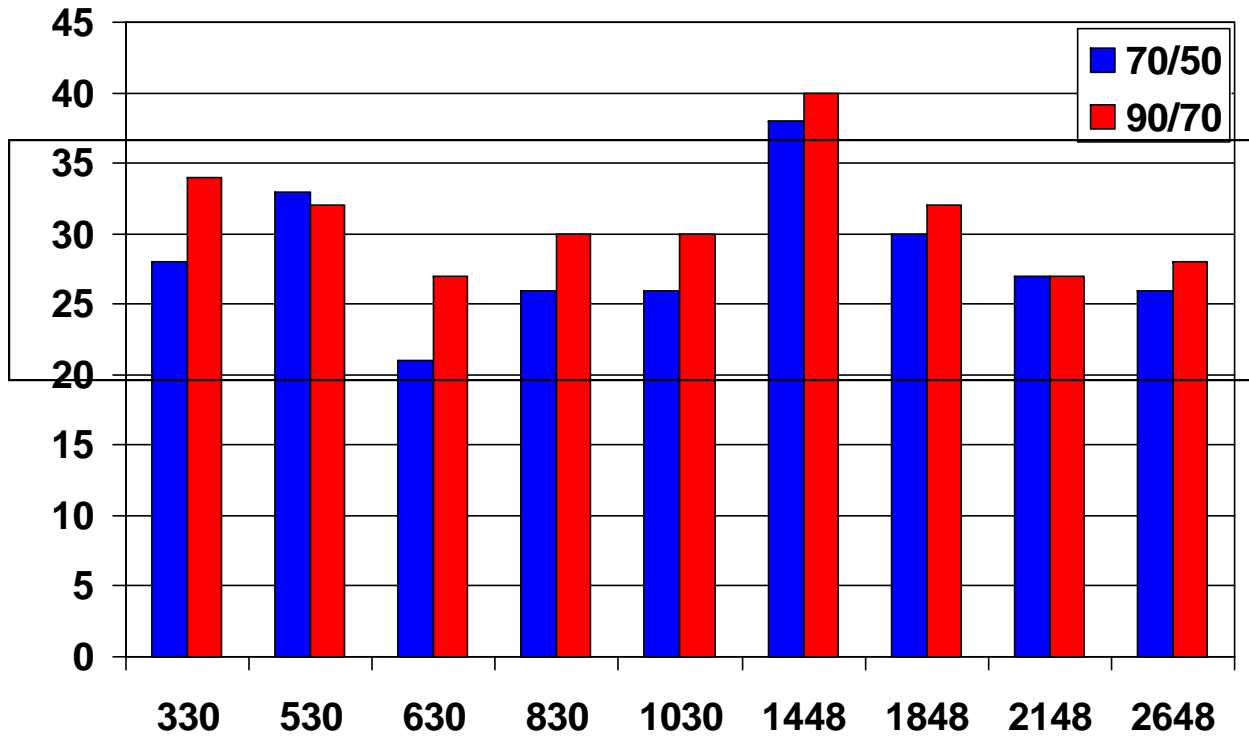

# Suction Pressures, Harvest

PSIG

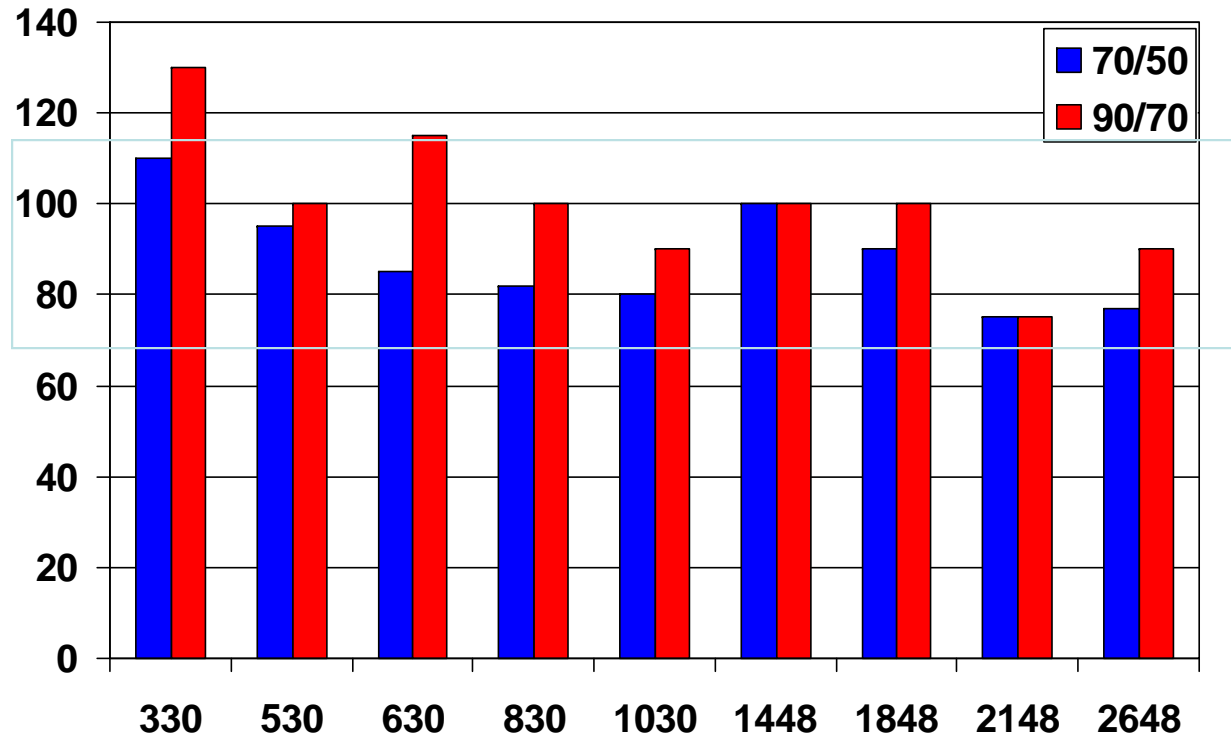

# AutoAlert Light Panel

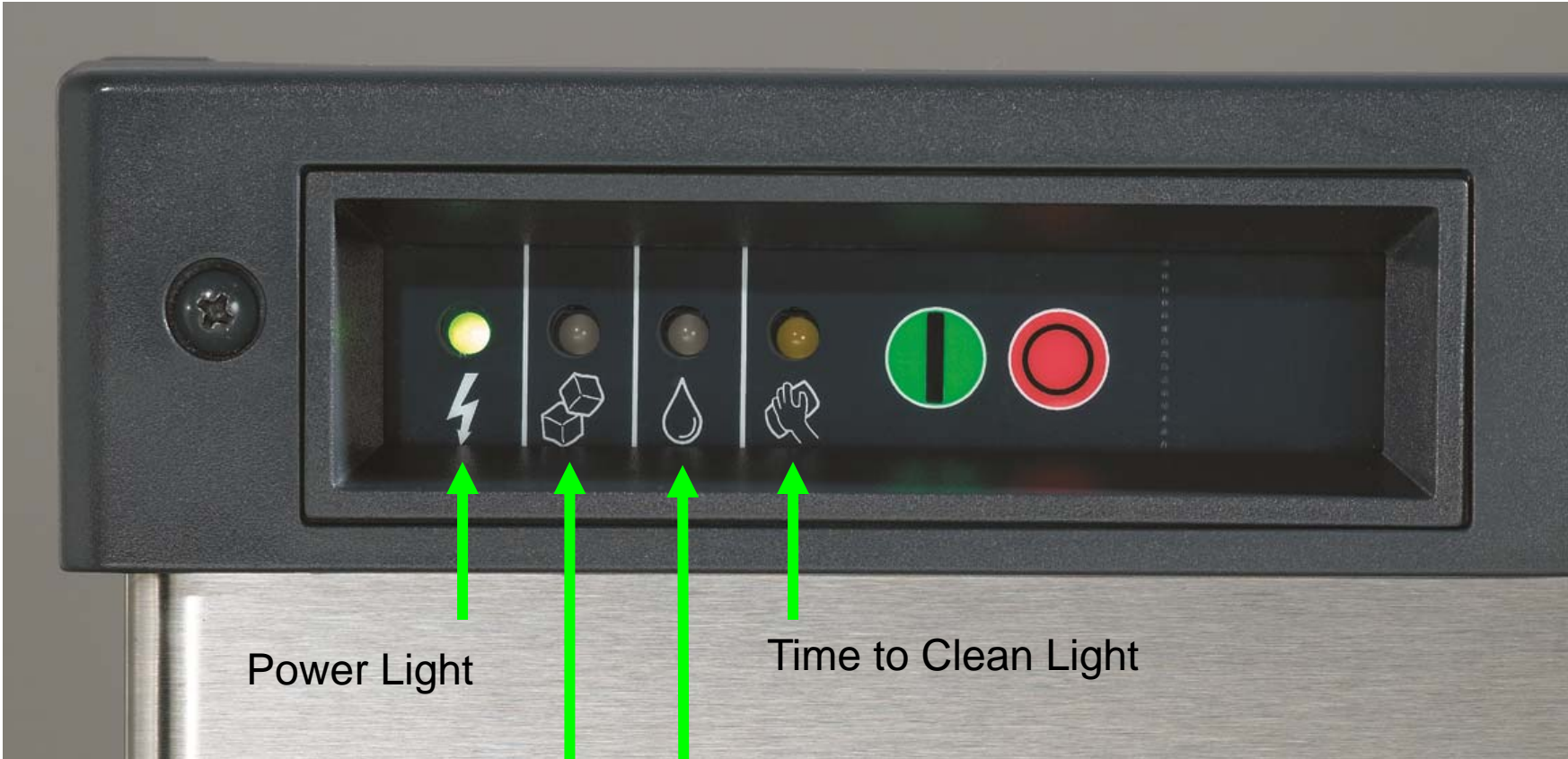

Power Light

Time to Clean Light

Status Light

Water Light

# AutoAlert Light Panel



On Switch Button

Off Switch Button

# Prodigy Controller

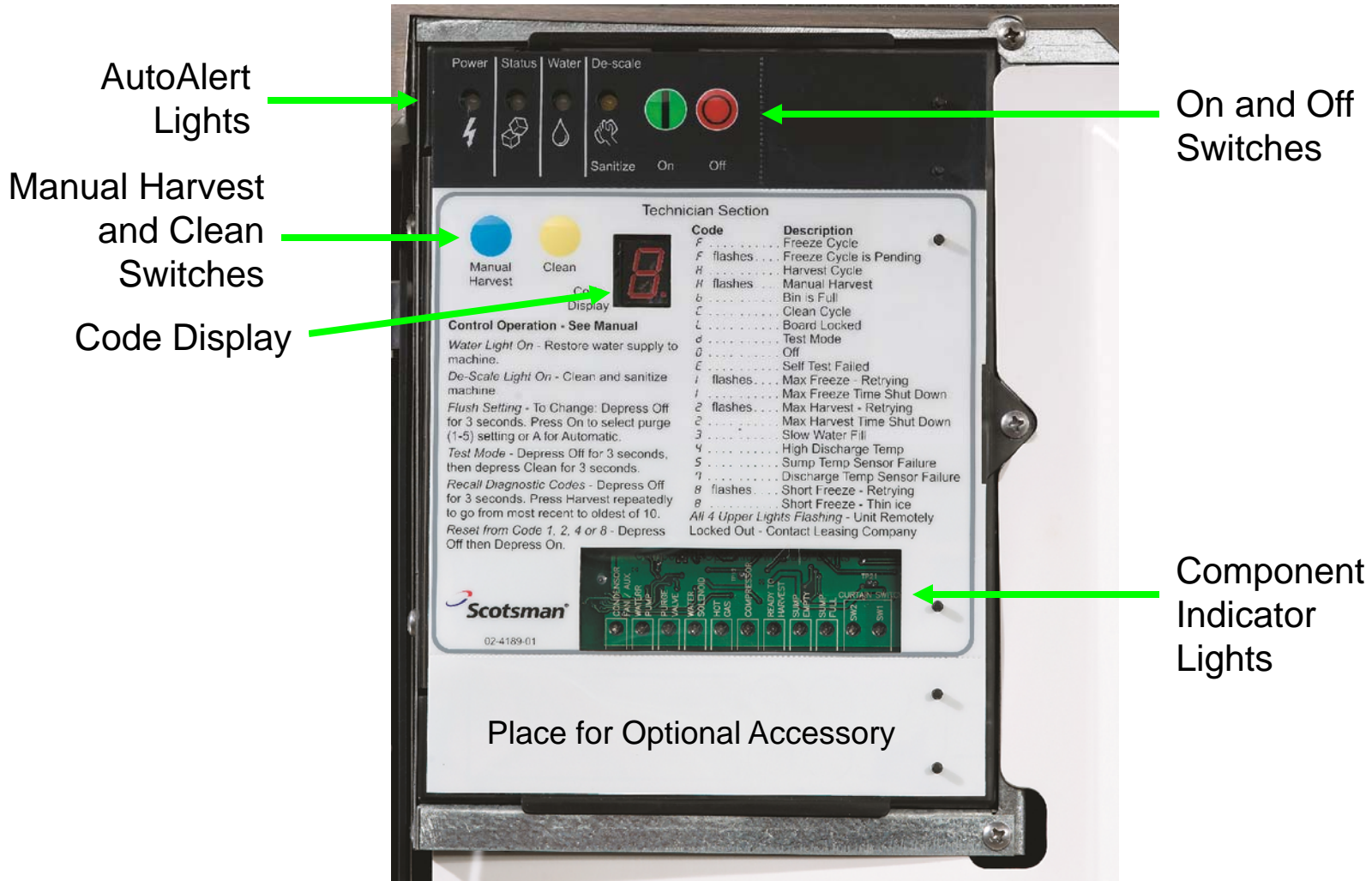

# Code Display

- Letter codes show operational status
- Number codes show shut down causes

Technician Section	
Code	Description
F	Freeze Cycle
F flashes	Freeze Cycle is Pending
H	Harvest Cycle
H flashes	Manual Harvest
b	Bin is Full
E	Clean Cycle
L	Board Locked
d	Test Mode
0	Off
E	Self Test Failed
1 flashes	Max Freeze - Retrying
1	Max Freeze Time Shut Down
2 flashes	Max Harvest - Retrying
2	Max Harvest Time Shut Down
3	Slow Water Fill
4	High Discharge Temp
5	Sump Temp Sensor Failure
7	Discharge Temp Sensor Failure
8 flashes	Short Freeze - Retrying
8	Short Freeze - Thin ice
<i>All 4 Upper Lights Flashing</i> - Unit Remotely Locked Out - Contact Leasing Company	

## 5 Controller Shut Down Causes

- Exceeds limit on water fill time
  - 5 minutes
- Exceeds limit on maximum freeze time
  - 45 minutes
- Exceeds limit on maximum harvest time
  - 3.5 minutes
- End of freeze triggered too soon
  - Before 6 minutes into the freeze cycle
- Discharge temperature too high
  - Exceeds 250 degrees F.

## Controller Reaction

- Exceeds water fill time
  - Shuts down, attempts refill every 20 minutes
- Exceeds maximum freeze time
  - Completes harvest, tries another cycle
- Exceeds maximum harvest time
  - Shuts down, restarts after 50 minutes
- End of freeze triggered too soon
  - Completes timed harvest, tries another cycle.
- Discharge temperature exceeds 250 degrees F.
  - Immediate shut down



# Cuber Controller Auto Restart

- From diagnostic causes
  - Retries 2 times, if fails again 3rd time, machine must be manually reset
- From water interruption
  - Will continuously restart every 20 minutes
- From power failure
  - Goes thru a timed harvest (3 minutes)

# Controller Button Processes

- Reset
  - Push and release Off, push and release On

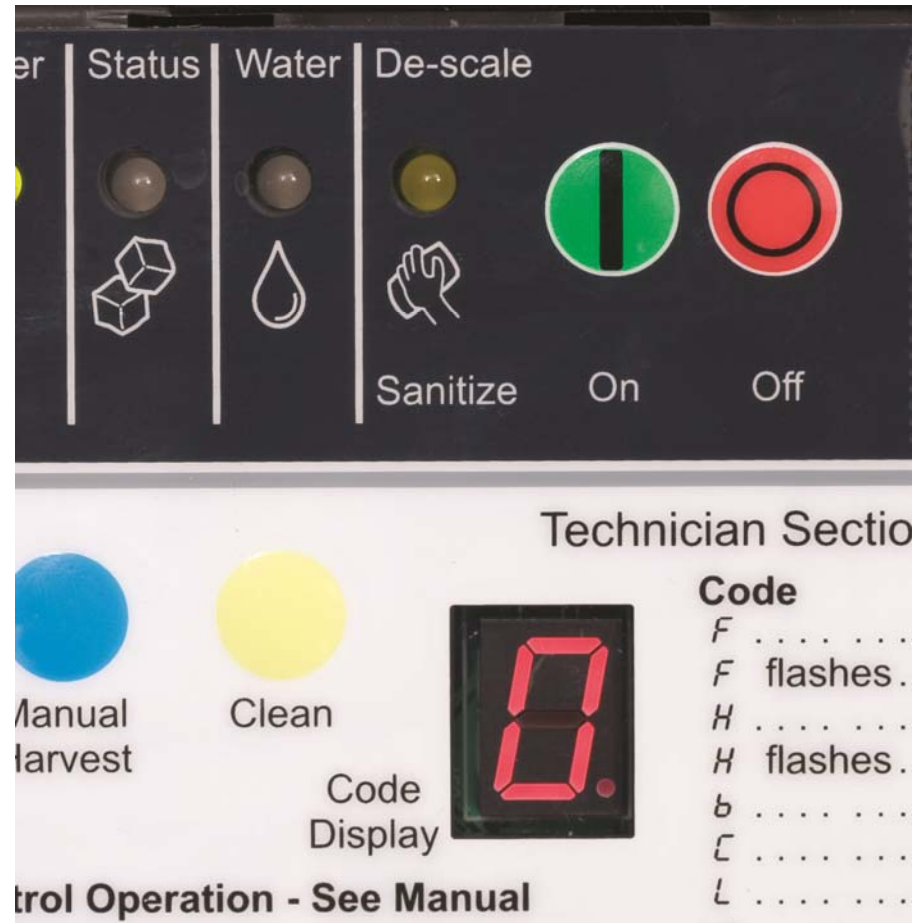

# Cuber Control Button Use

- Recall diagnostic code
  - Push and hold Off to shut the machine down
  - Push and hold Off again until the display code changes
  - Push and release the Harvest button to cycle through the last 10 diagnostic codes, from latest to oldest



# Cuber Controller Button Use

- Clear all diagnostic codes
  - Push and hold Off to shut the machine down
  - Push and hold both the Clean and Harvest buttons for 3 seconds

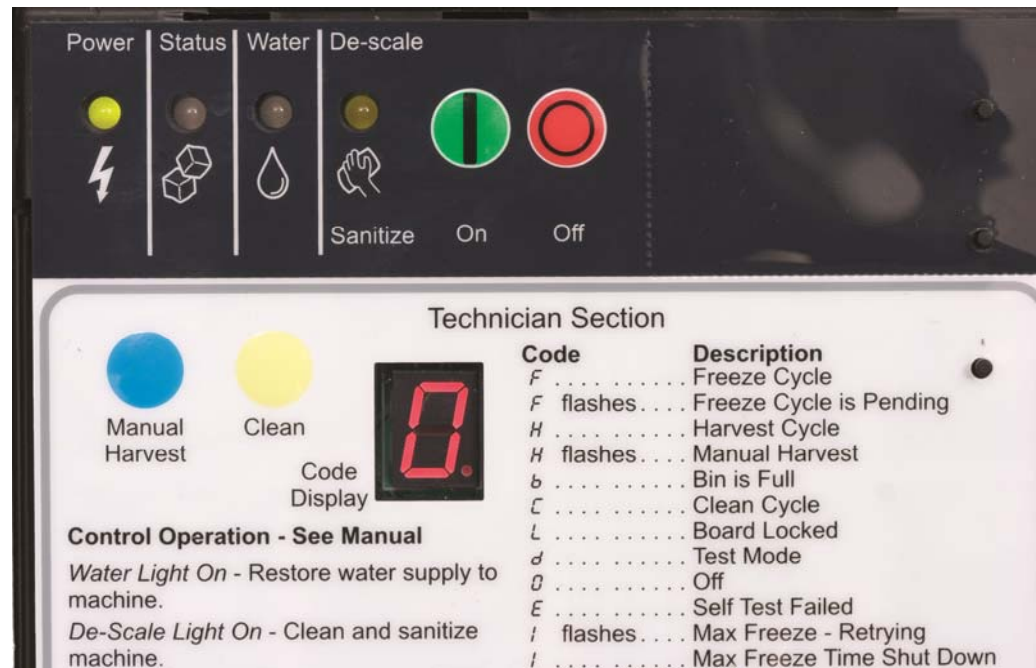

# Cuber Controller Button Use

- View/Change water purge
  - Push and hold Off to shut the machine down
  - Push and hold Off again until the display code changes – code displayed is the current purge setting
  - Press and release the On button to cycle to another setting – 1 to 5 or A for Automatic



## WaterSense Automatic Purge

- Controller measures conductivity of the reservoir water
- Adjusts purge water amount based on the water's dissolved solids
  - Display shows an A if set to Automatic (factory default)
- Purge can also be manually set
  - 1 is minimum
  - 5 is maximum

## Other Controller Button Processes

- Empty reservoir
  - Push and hold Off to shut the machine down
  - Push and hold Clean button until the display shows a dash, pump will drain the reservoir for 30 seconds, repeat as needed



# Cyber Diagnostics



## Diagnostic Aids

- Use the controller's component indicator lights to check if a component is operating when it should be.

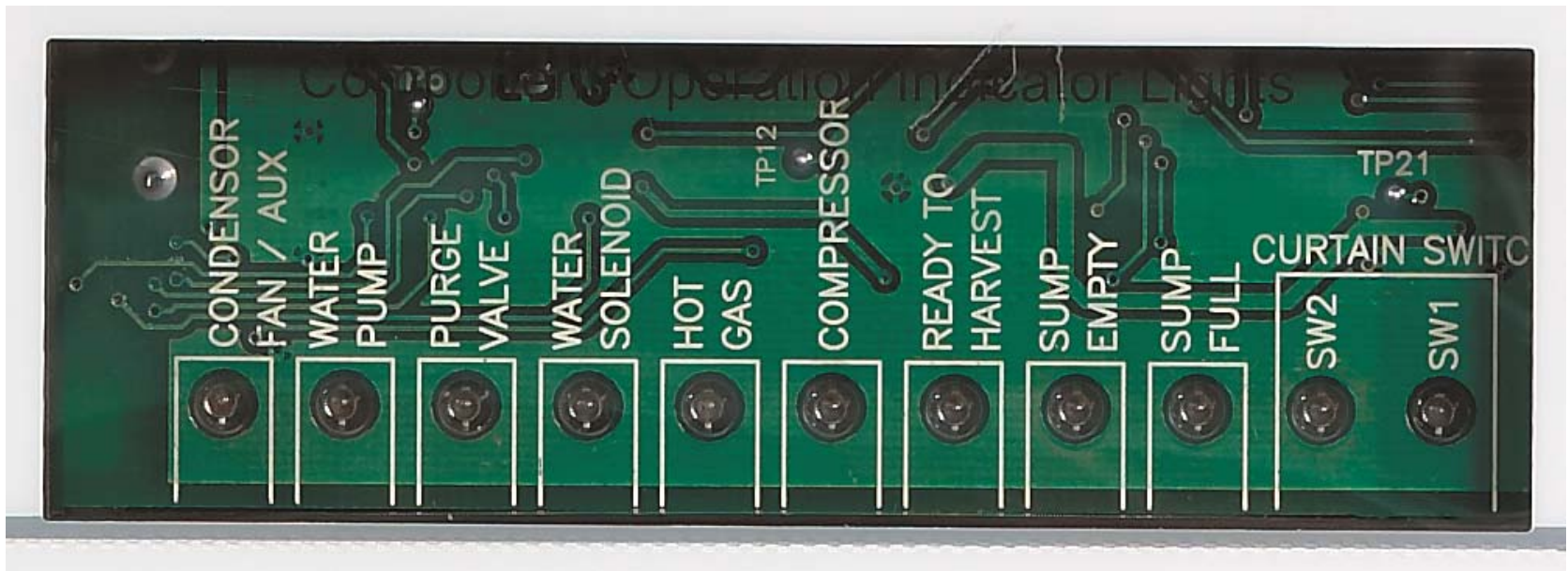

## Example: Freeze Cycle

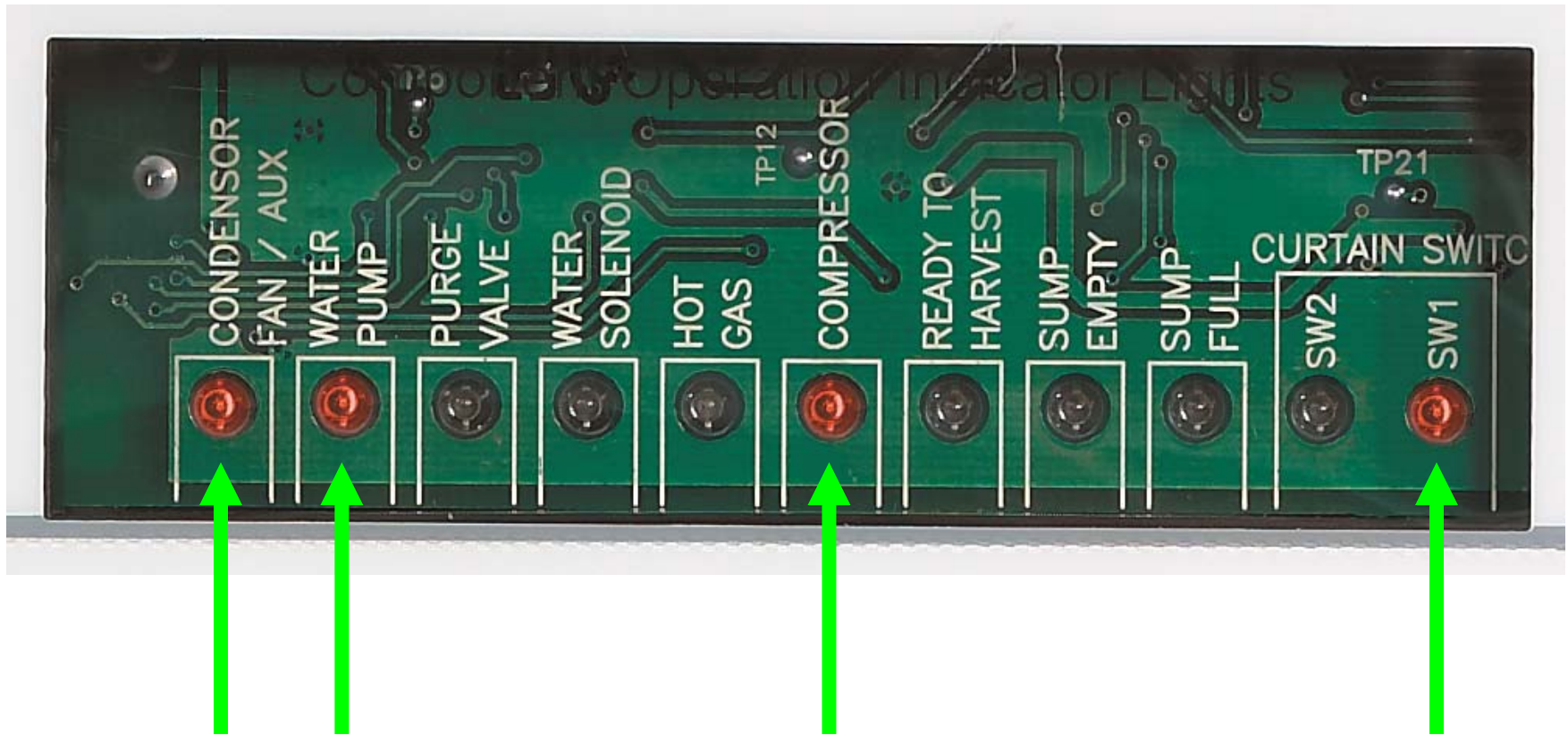

## Example: Harvest Cycle

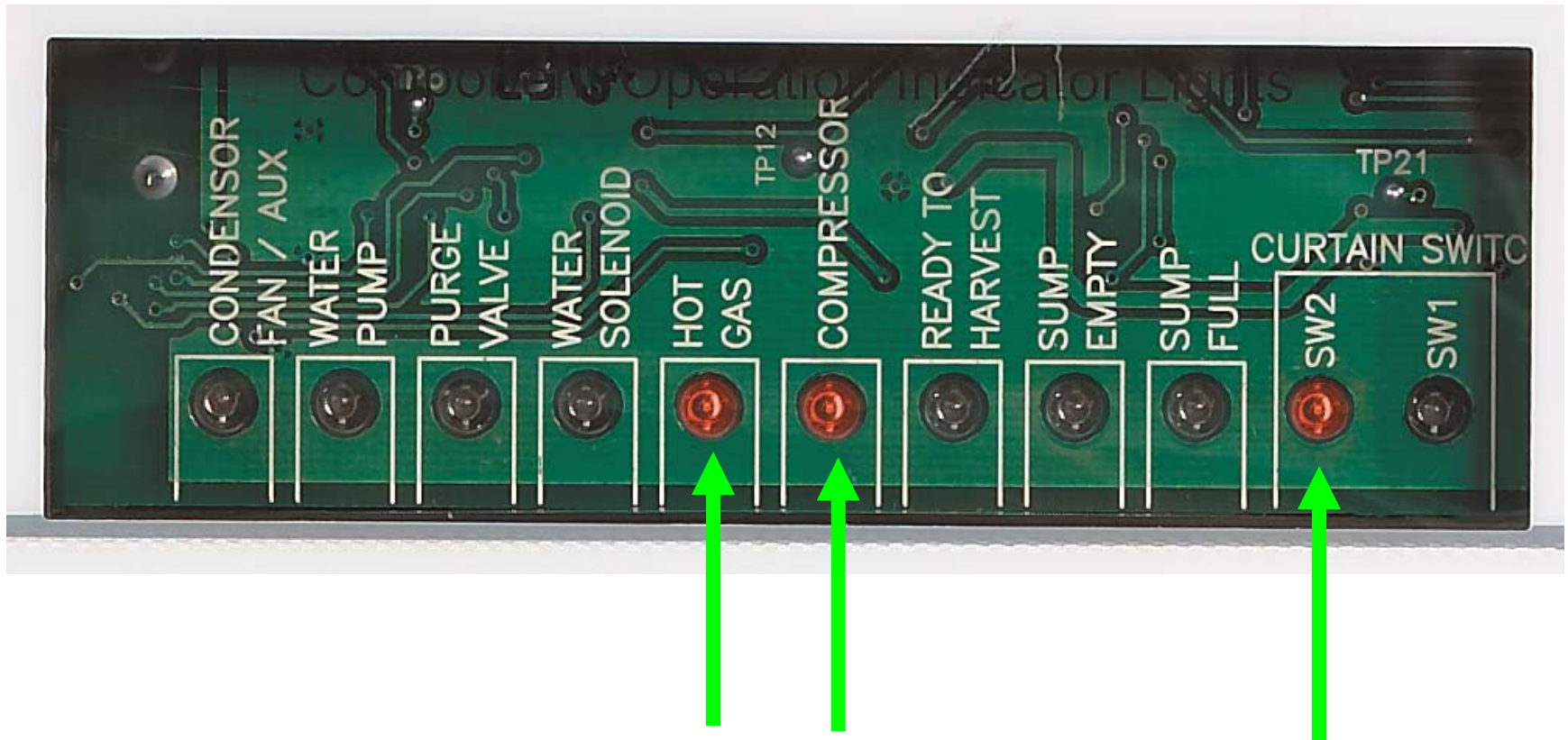

# Diagnostic – Line Voltage Outputs

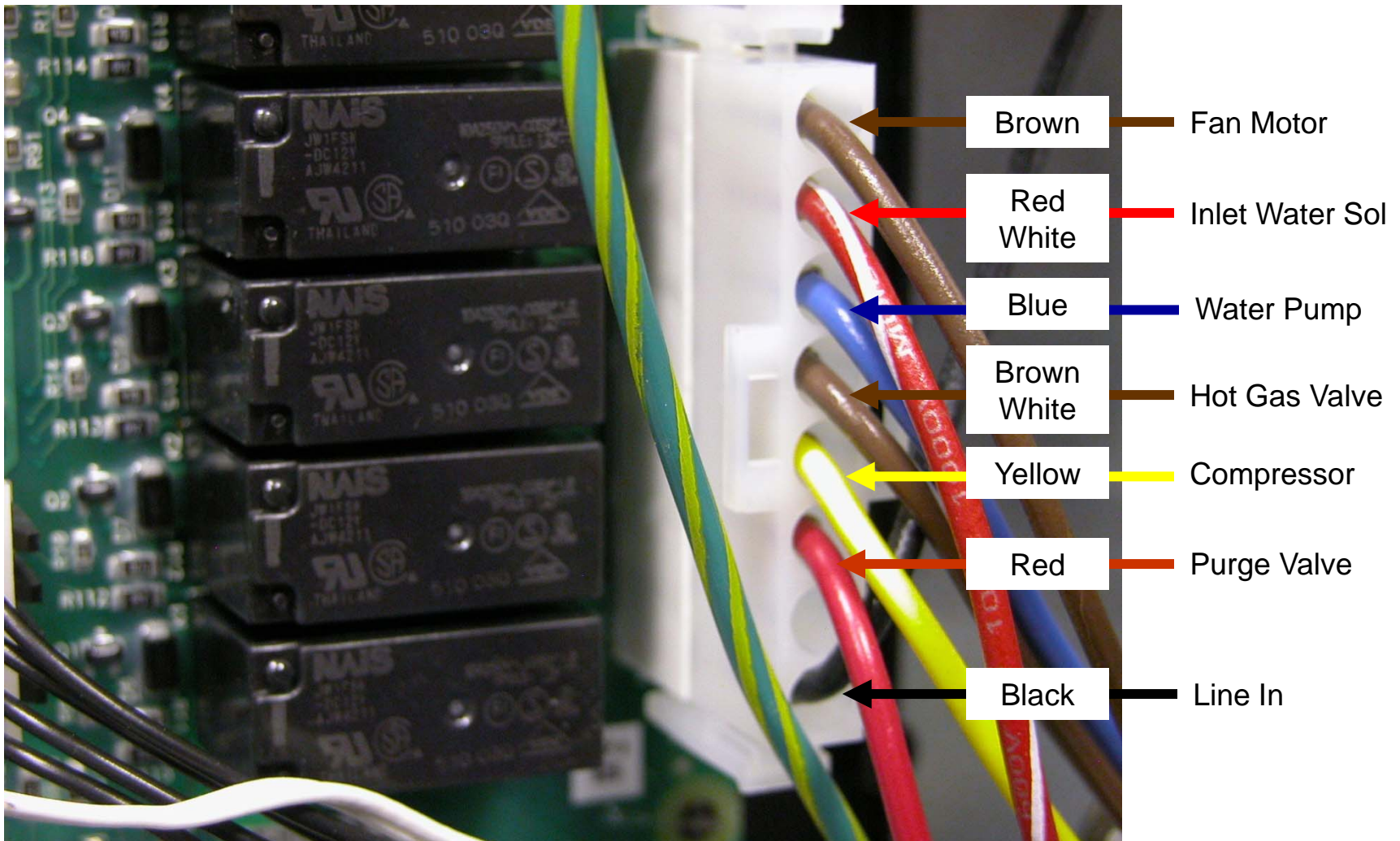

# Diagnostic Process

- Check diagnostic code
  - Use codes as a guide to the root cause
  - Codes listed on the controller overlay
- Remember the Recipe for Ice – a malfunction will be in one of these areas:
  - Water
  - Refrigeration
  - Electrical

# Diagnostics

- Max freeze time diagnostic – Code 1
  - Limit is 45 minutes
  - Typical cycle is much shorter
    - 15 to 20 minutes
  - Long freeze cycle causes:
    - Lack of water
    - Lack of refrigeration effect
    - Not sensing ice formation



## Diagnostics – Code 1

- Lack of water flow potential causes:
  - Water pump failure
  - Leaking pump hose
  - False Sump Full signal from Water Level Sensor
- Lack of refrigeration may be caused by:
  - Dirty air filters
  - Fan motor or fan pressure control failure
  - Water supply to water cooled condenser failure
  - Low charge
  - TXV superheat not correct
  - Compressor contactor failure
  - Compressor overheated or off

## Diagnostic – Water Pump

- Check pump for operation during freeze
  - When diagnostic light is ON pump should be operating





# Diagnostic – Fan Motor

- Two controls – controller and fan pressure switch
  - Controller light ON when fan should be ON
  - Pressure switch then controls power to fan motor
    - Jump pressure switch wires

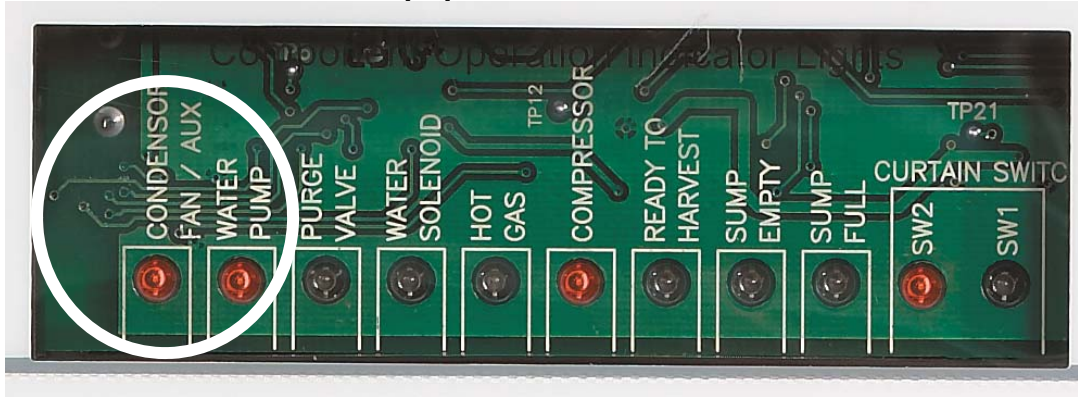
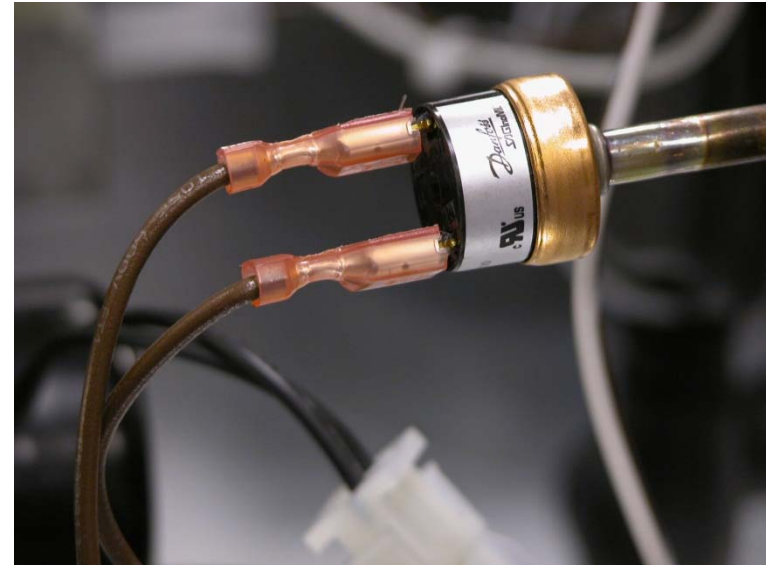

# Diagnostic - Sensors

- Water Level Sensor
  - Continuity probe
  - Check by connecting two short probes
  - Sump full light should be On
  - Must be OFF if nothing touches the probes

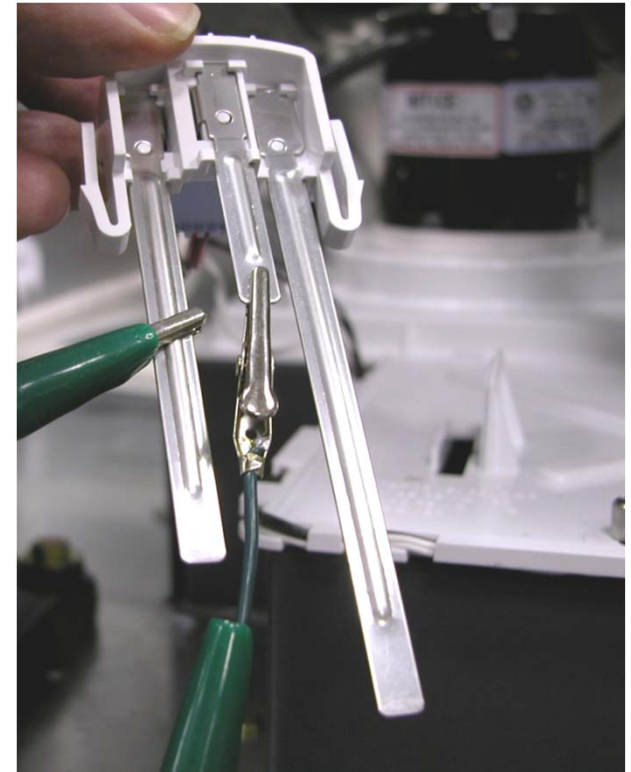
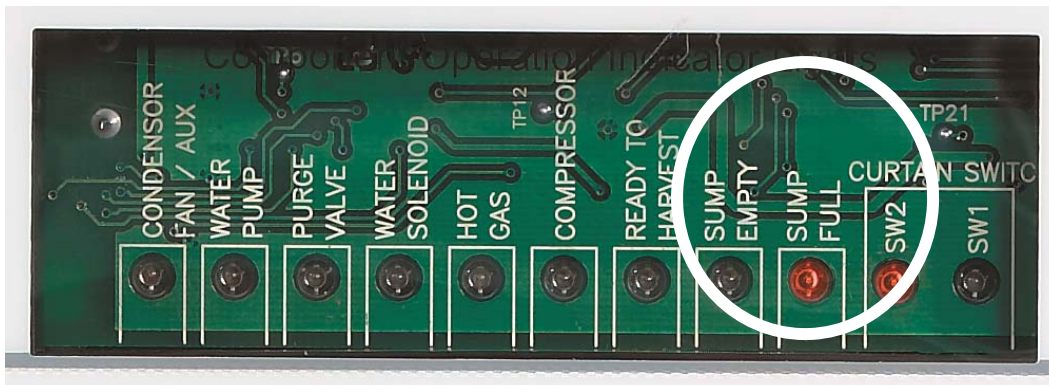

# Diagnostics - Code 1

- Control system not sensing correctly
  - Sensor dirty
    - Ice thickness – large bridge
    - Water level – reservoir empty and Sump Full light on
  - Broken wire
  - Out of adjustment
  - Controller not getting signal
    - Check Ready to Harvest Light

# Diagnostics - Sensors

- Ice thickness sensor
  - It is a continuity probe
  - Check by grounding metal tip to cabinet and observing Ready To Harvest light

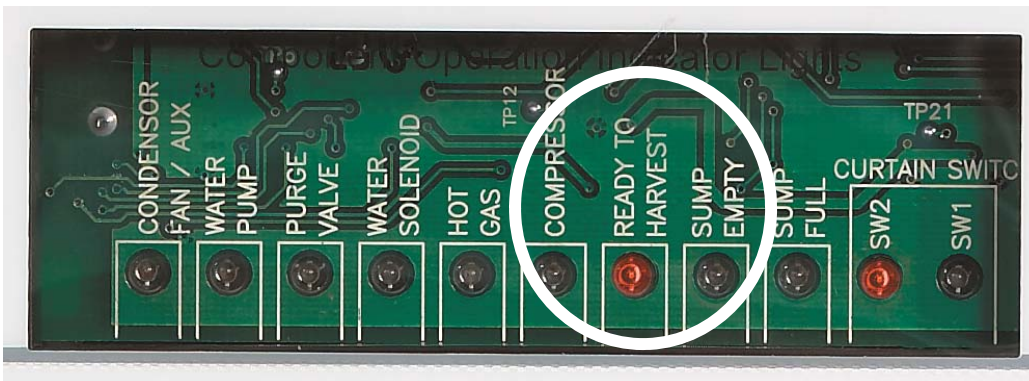
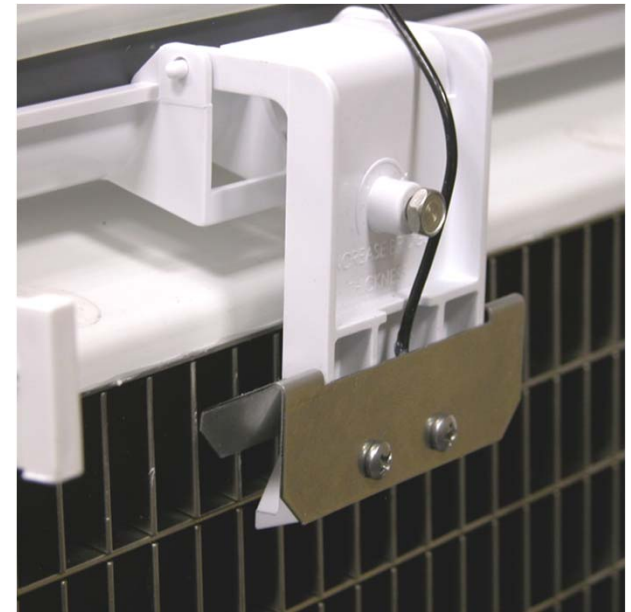

# Diagnostics

- Max harvest time – Code 2
  - Limit is 3 ½ minutes
  - Normal time is between one and two minutes
  - Long harvest cycle possibly caused by:
    - Harvest assist solenoid not functioning correctly
      - Not extending or retracting
    - Hot gas valve not opening
    - Curtain switch not sensing when curtain opens
    - Poor or No ice formation
    - Low refrigerant charge



# Diagnostic – Harvest Assist Solenoid

- Operates when the Hot Gas valve is energized
  - Check during harvest, if voltage is present, pin should extend when ice releases

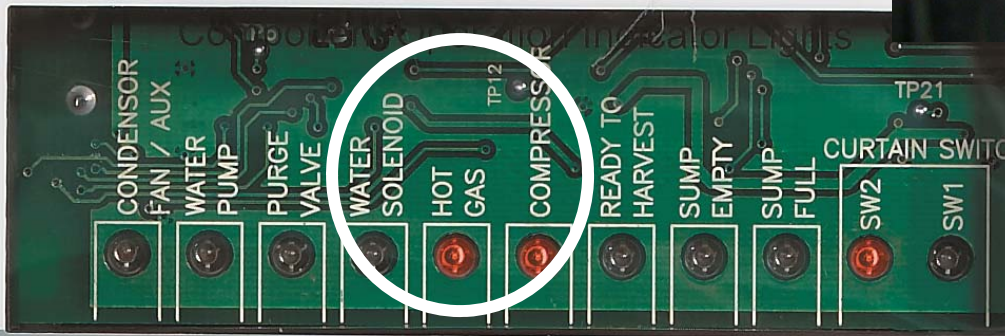
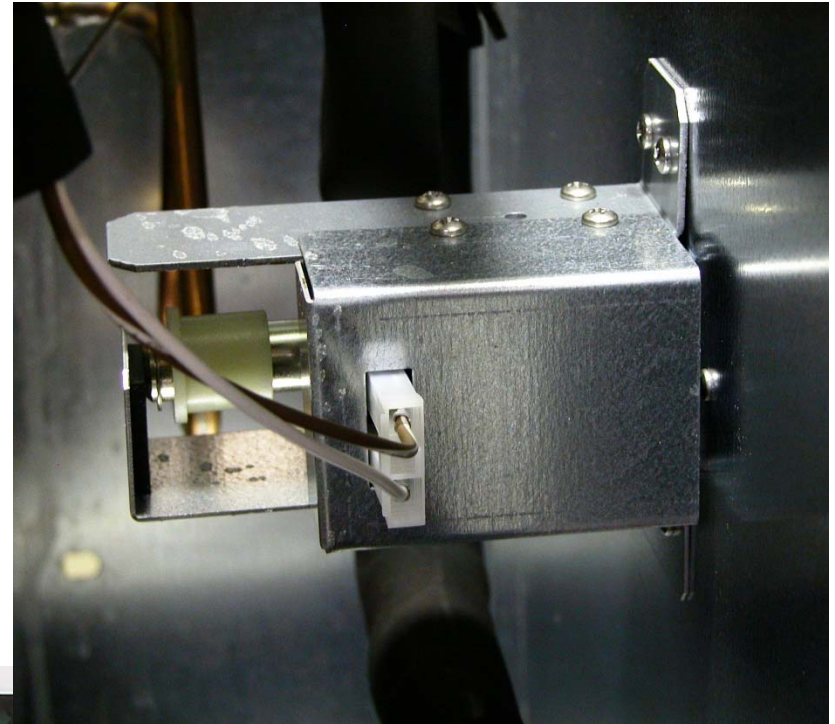

Note: Harvest assist solenoid coil cannot be checked with an ohmmeter. Check voltage instead.

## C2648 Harvest Assist Solenoids

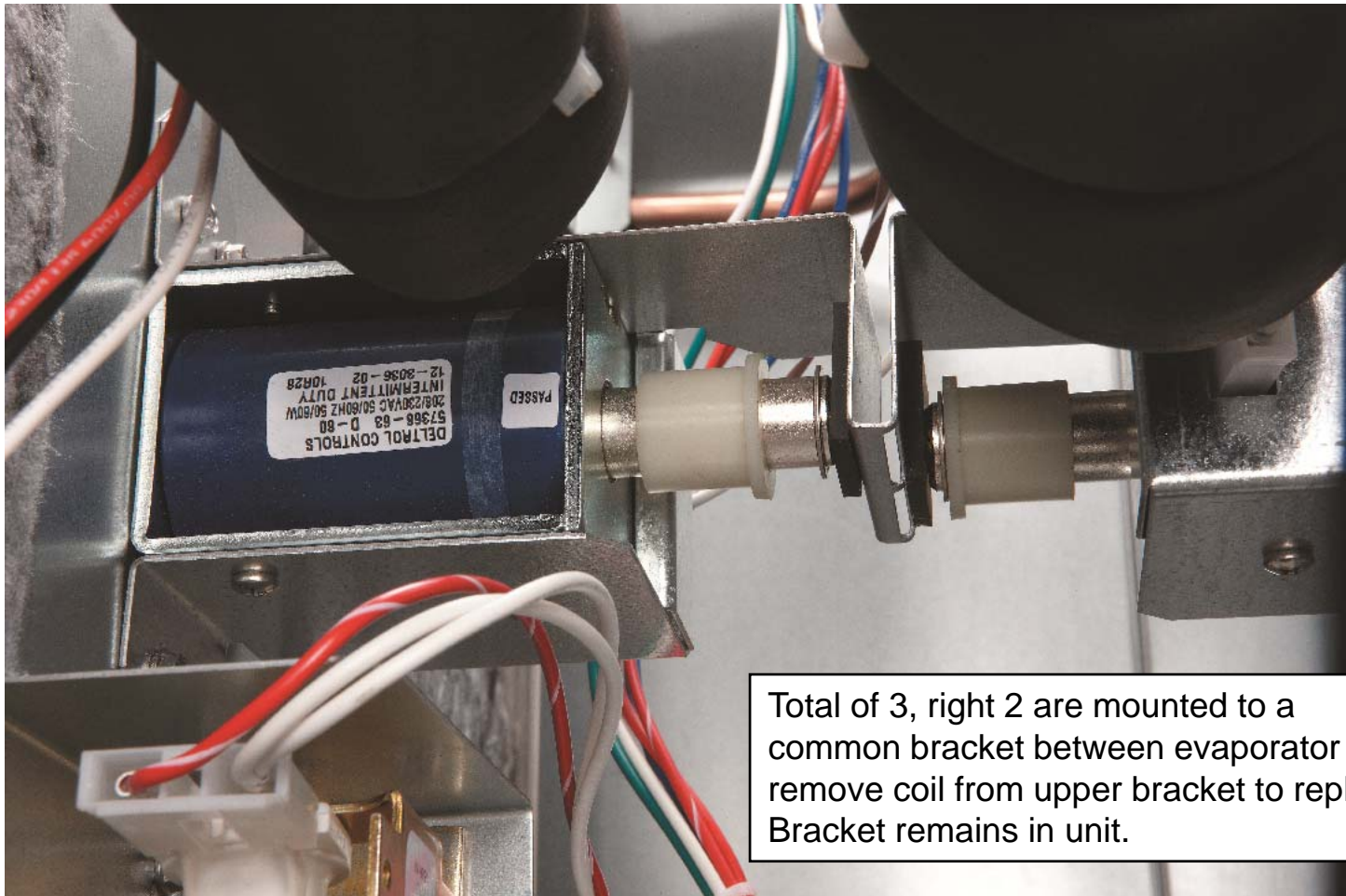

Total of 3, right 2 are mounted to a common bracket between evaporator walls, remove coil from upper bracket to replace. Bracket remains in unit.

## Diagnostic – Harvest Assist Solenoid

- Spring retracts pin when power is off
  - If pin does not retract, check for binding in evaporator bushing

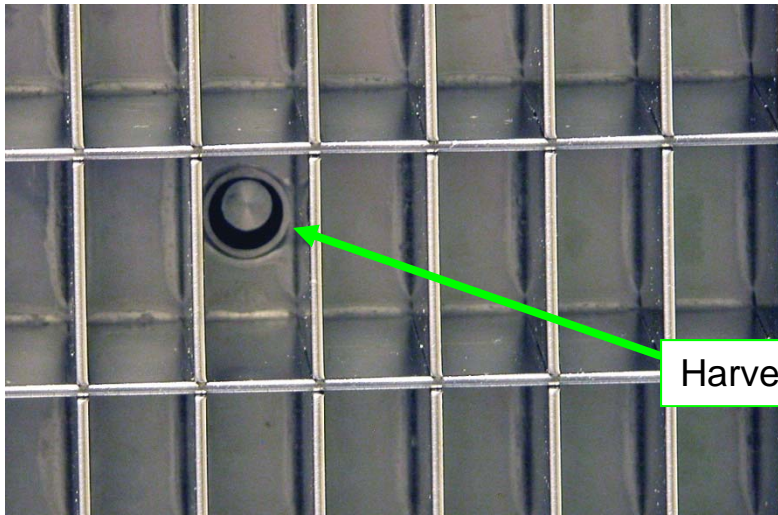
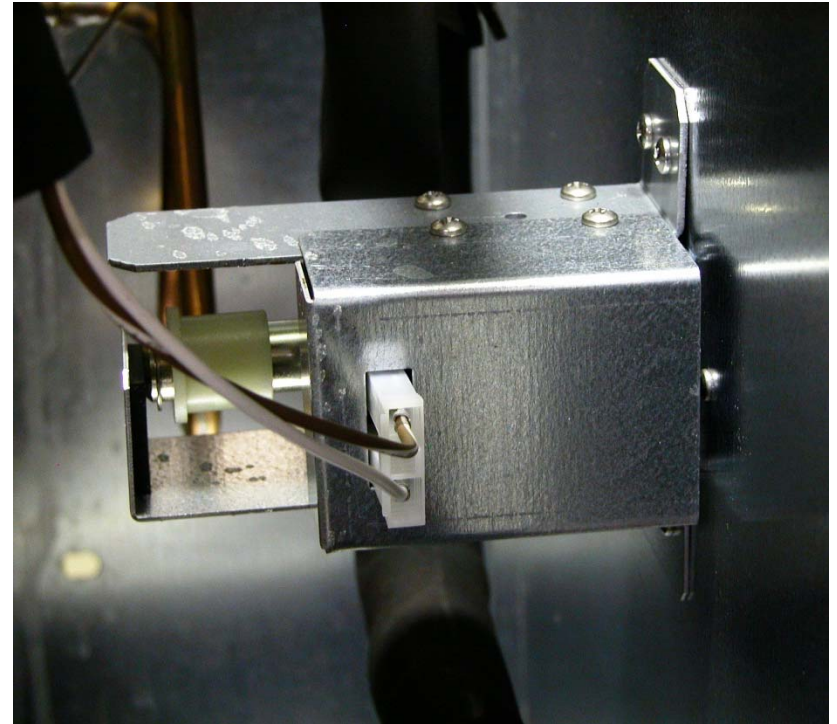

Harvest Assist Solenoid Pin



# Diagnostic - Sensors

- Curtain Switch

- Magnetic reed switch
- Check with indicator light or ohmmeter
- When curtain is CLOSED, light is OFF
  - Single plate models have 1 light on all the time

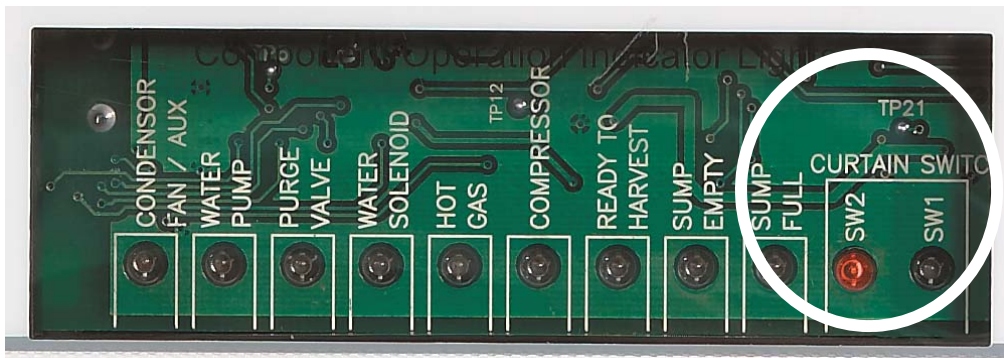

## Diagnostic – Hot Gas Valve

- Opens at start up and during harvest
- Line voltage coil
- Check power to coil when hot gas indicator light is on
- Check resistance of coil when unplugged

## Diagnostic – Water Level Sensor

- Sump Full light ON, but no water in reservoir - Code 2 displayed.
- Cause: dirty sensor
  - Solution: clean sensor
    - Release probes from holder
    - Clean probes and holder thoroughly

To Release:  
Push pin in,  
pull probe  
down

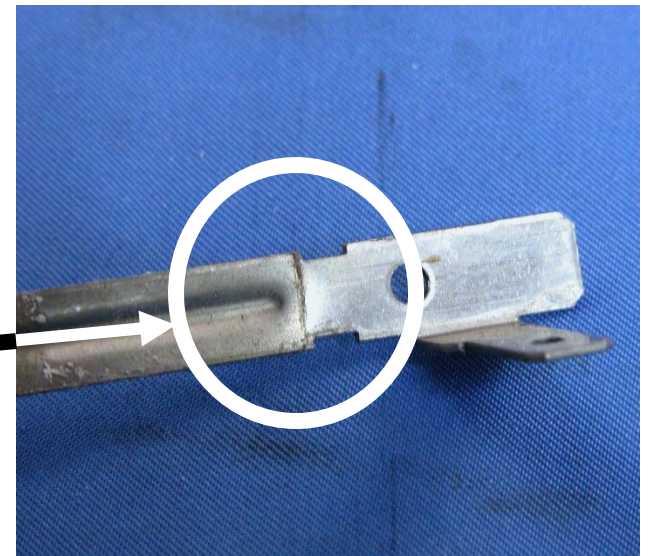
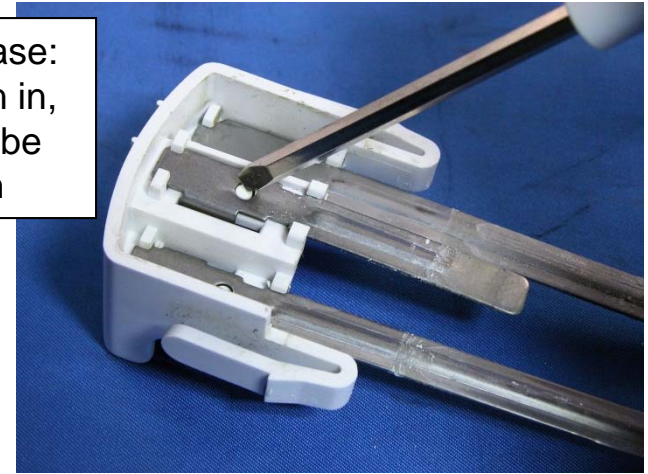

Key Area to Clean

# Diagnostics

- Slow or no water fill – Code 3
  - Limit on fill time is 5 minutes
  - Longer fill times possibly caused by:
    - Water supply shut off
    - Water filters plugged up
    - Inlet water solenoid valve failure
    - Controller not opening inlet water solenoid valve
    - Water leak



# Diagnostic – Water Valves

- Shut unit off, restart
- Observe indicator lights,
  - Purge valve and water solenoid should be ON and Operating during a restart

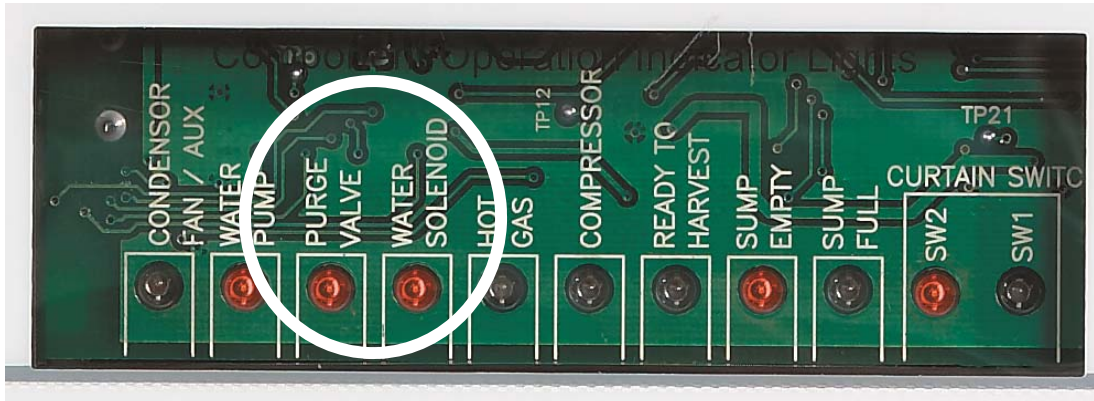

Note: Purge valve cannot be checked with an ohmmeter. Check voltage instead.

# C2648 Inlet Water and Purge Valves



## Inlet Water Solenoid Valve

- Quick test: In Freeze, pull Water Level Sensor out of reservoir – Sump Empty light will switch ON and Inlet Water Solenoid Valve should open to fill the reservoir.

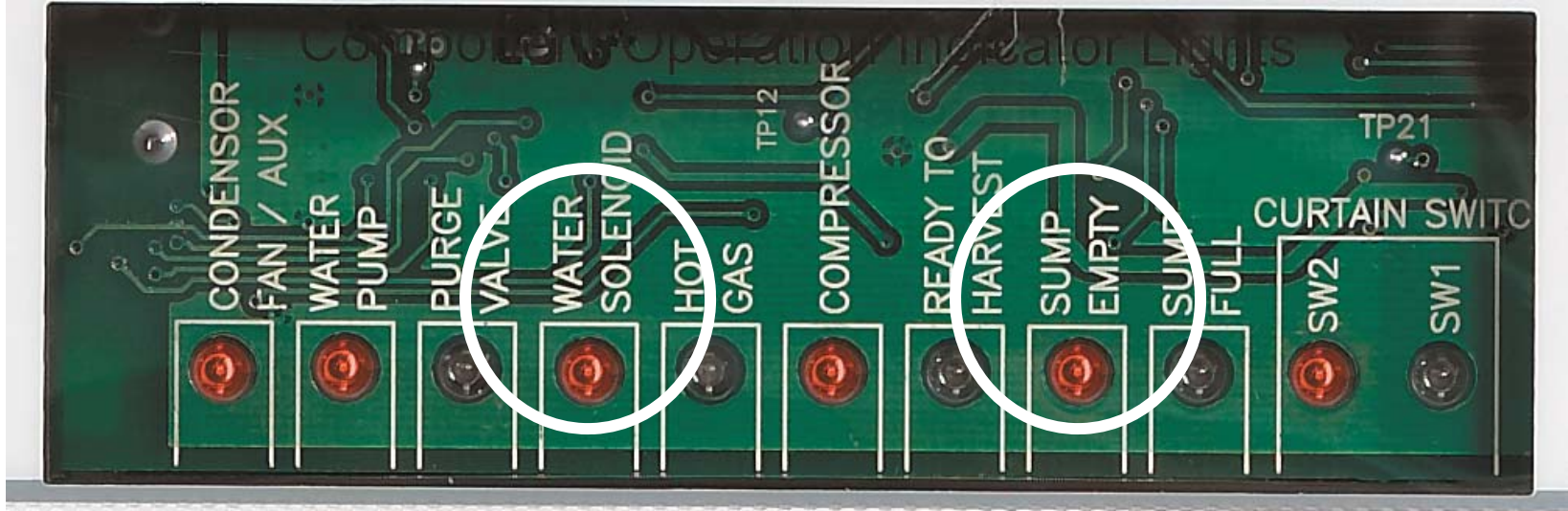

## C2648: Unique Electricals

- Two pumps
  - Front one connected to NC purge valve relay contacts
  - Back one connected directly to controller relay
  - In drain mode, purge valve relay opens circuit to front pump, back pump operates, front one does not.
- Harvest Assists & Hot Gas Valves
  - Operated by a separate relay



C2648  
Refrigeration

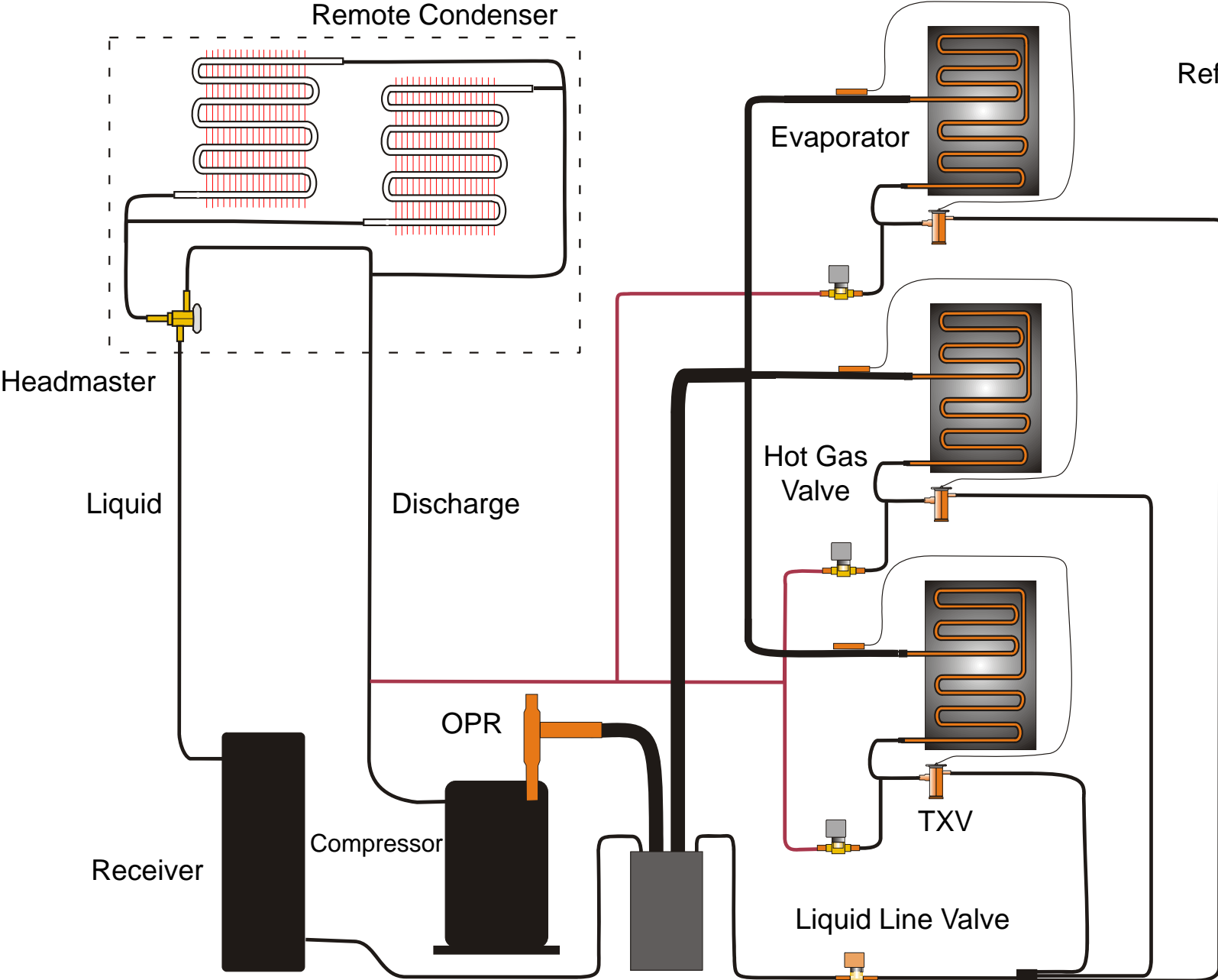

# Diagnostics

- High discharge temperature – Code 4
  - Immediate and complete shut off if discharge temperature reaches 250°F.
  - Possible causes of high discharge temperature
    - Fan motor failure
    - Extreme high ambient
    - Hot gas valve leak thru
    - Too much superheat



## Diagnostic - Sensors

- Display codes 5 or 7 indicate a sensor failure
  - Check by measuring resistance of thermistor and comparing to the table at that temperature
    - Table of resistances in manual or handbook, same as for CM3
- Operation can continue without thermistor use, diagnostic code 5 will be displayed when they are disconnected



# Diagnostics

- Short freeze cycle – Code 8
  - Freeze cycle triggered before 6 minutes
  - Possible causes
    - **Improper water flow**, water continuously splashes onto ice thickness sensor
      - Scale build up in distributor and / or spillway
    - Improper ice formation and harvest, top part of batch remains on plate after bottom part releases
      - Bridge thickness too thin – not adjusted correctly
      - Ice formation varies over evaporator
        - » Too much superheat



## Code 8 – Water Flow Correction

- Lightly sand or scrub the spillway across the flow of water
  - Evens out water flow
  - Reduces splash onto ice thickness sensor probe



# Diagnostics - Sensors

- Ice thickness sensor
  - Short freeze may be caused by irregular water flow or mis-adjusted ice thickness sensor
    - Too thin may trigger harvest before 6 minutes of freeze

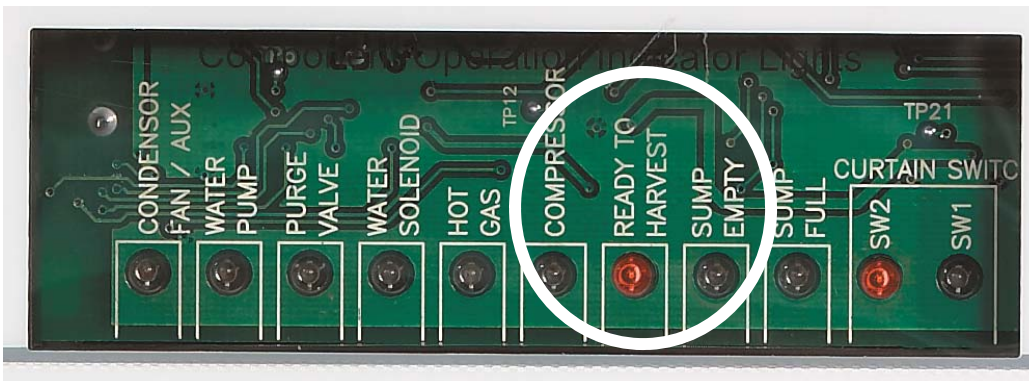
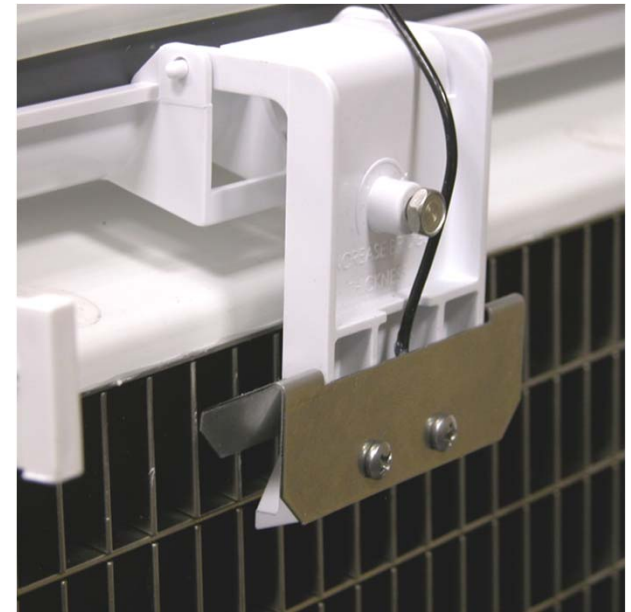

## Update: Change to ITS Material

- Probe holder made dark gray
  - Easier to see scale
  - No change to part number

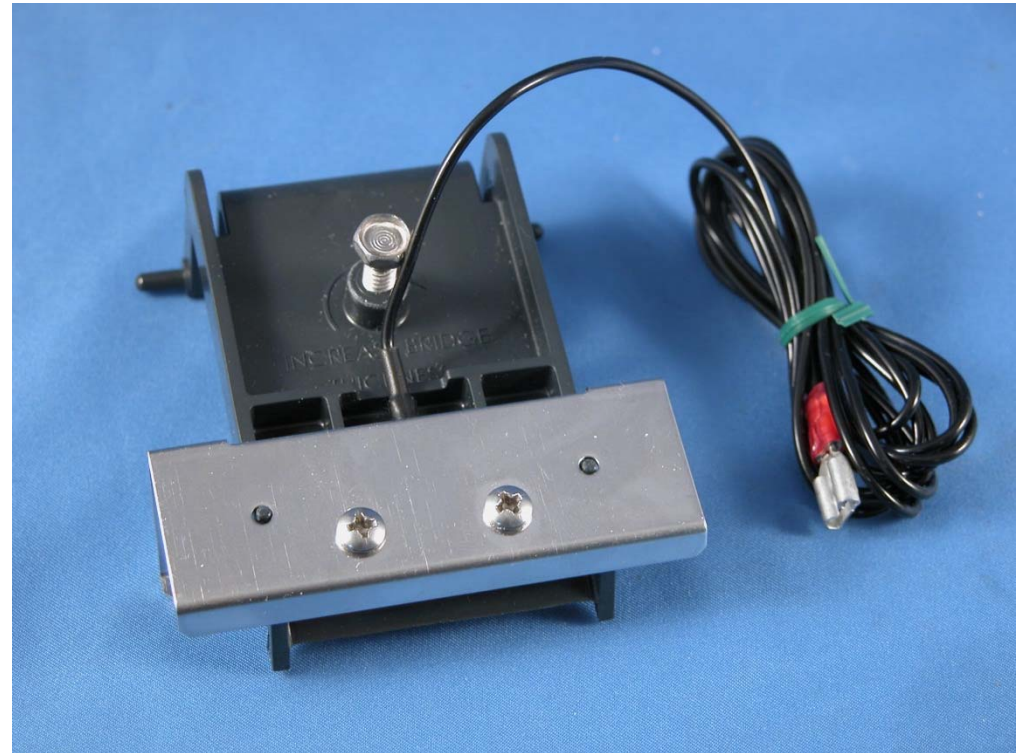

# Diagnostics

- No ice complaint
  - Machine is **not** making ice
  - Bin is **not** full
  - Status light is **Green**
  - Code **b** is displayed
  - Possible causes:
    - Curtain is open
    - Curtain switch is open
    - Vari-smart (KVS) is installed and set too low
      - Bin Full light will be ON



Knob's Arrow Should Point Up, not Down



# KVS

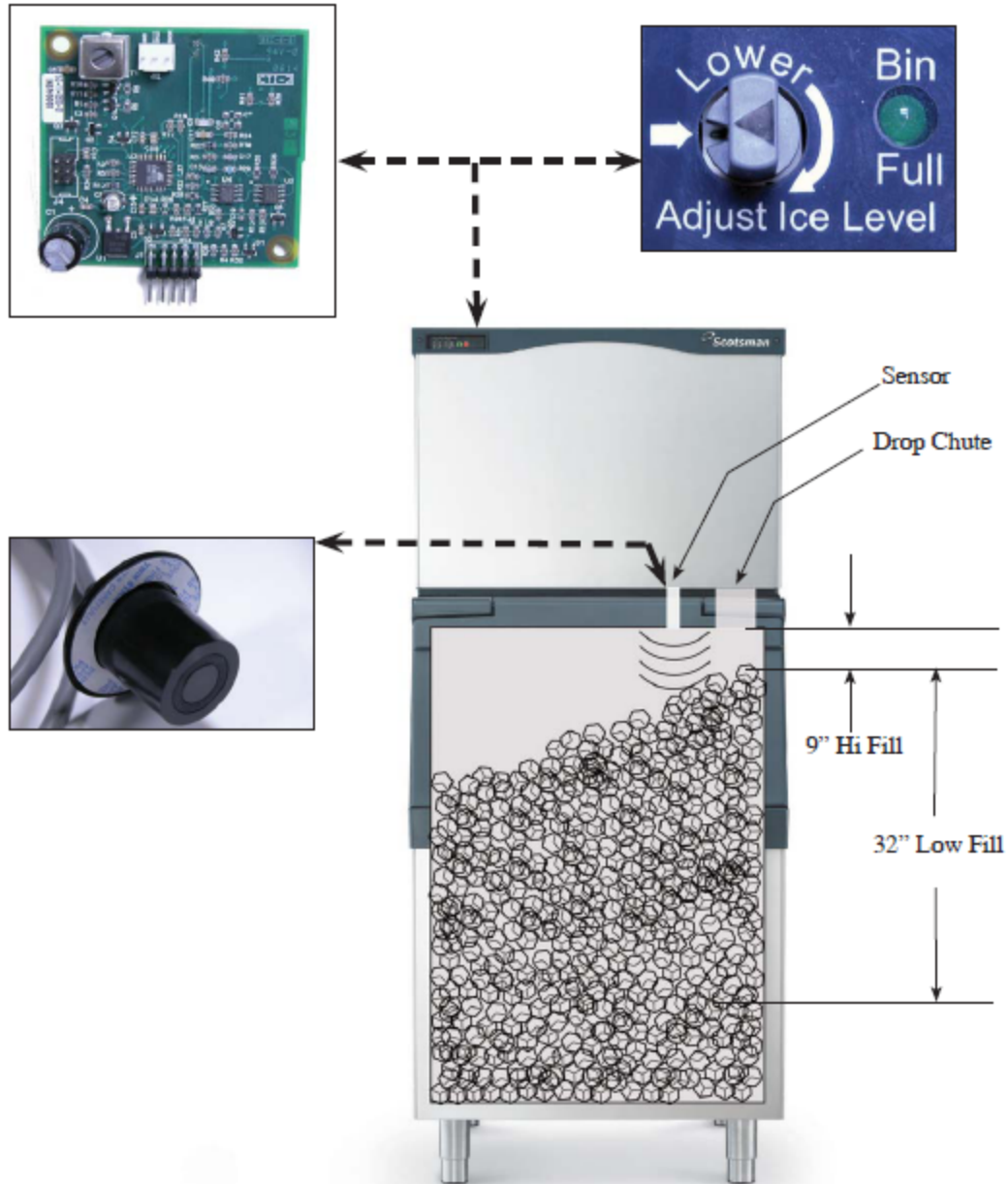

# Diagnostics – Curtain Switch

- Light is ON when switch is Open
  - Unused switch light is always on
- Move the curtain
  - Check if the light cycles with the curtain's movement or
  - Use ohmmeter on switch leads
    - Good is less than 5 ohms when closed

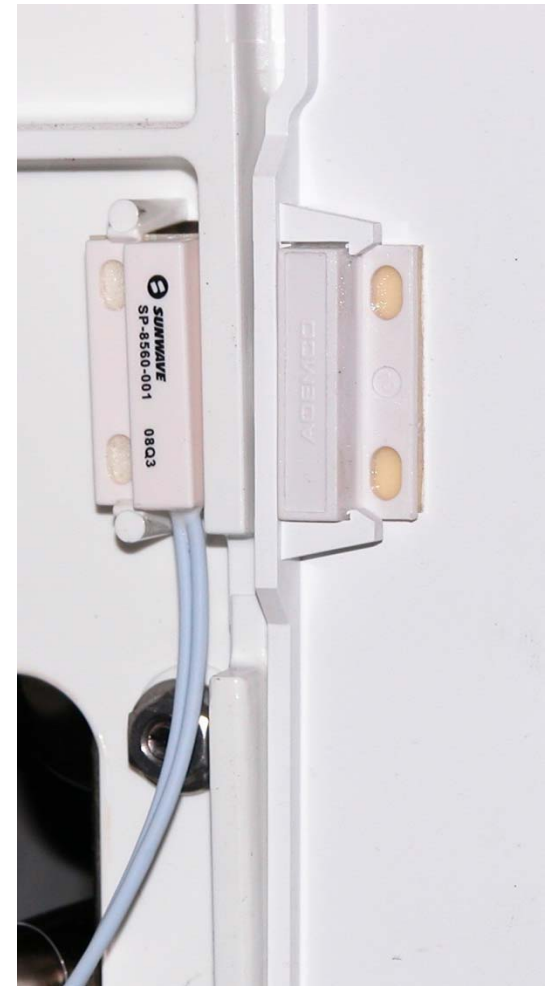
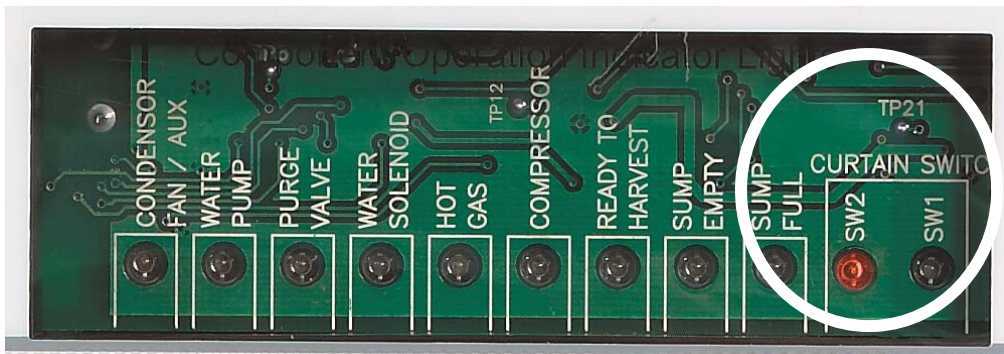

## Diagnostic – Test Mode

- Depress and HOLD Off until display changes then release
- Depress and HOLD Clean for 3 seconds
  - The controller will go through a programmed sequence of switching the components on and off.
    - The Diagnostic lights will switch on and so will the load
      - Fan motor is an exception, the fan pressure control will keep the fan motor off
    - If the light is ON and the load is not, further check of the motor or solenoid coil is required.
    - If the lights all match component operation, there is nothing wrong with either the controller or the components.

# Maintenance and Cleaning

# Maintenance

- Mineral scale
  - Water sensors and distributor become coated with scale
  - Use Scotsman Clear 1 scale remover to dissolve scale
  - Pay special attention to:
    - Water distributor
    - Ice thickness sensor
    - Water level sensor



# Cuber Clean Cycle

- Harvest ice / stop machine
- Push clean button
  - When Purge Valve Light goes OUT, add scale remover
  - Circulate scale remover as long as you like
- Push Clean button again
  - Drains and refills
  - Operate this way for 20 minutes or more
- Push Off to stop
  - Resets the Cleaning Indicator Light

## Water Distributor

- Release catches, pull and lift off mounting track
- Pull cover off, rinse out



# Ice Thickness Sensor

- Wipe inside surface clean with scale remover

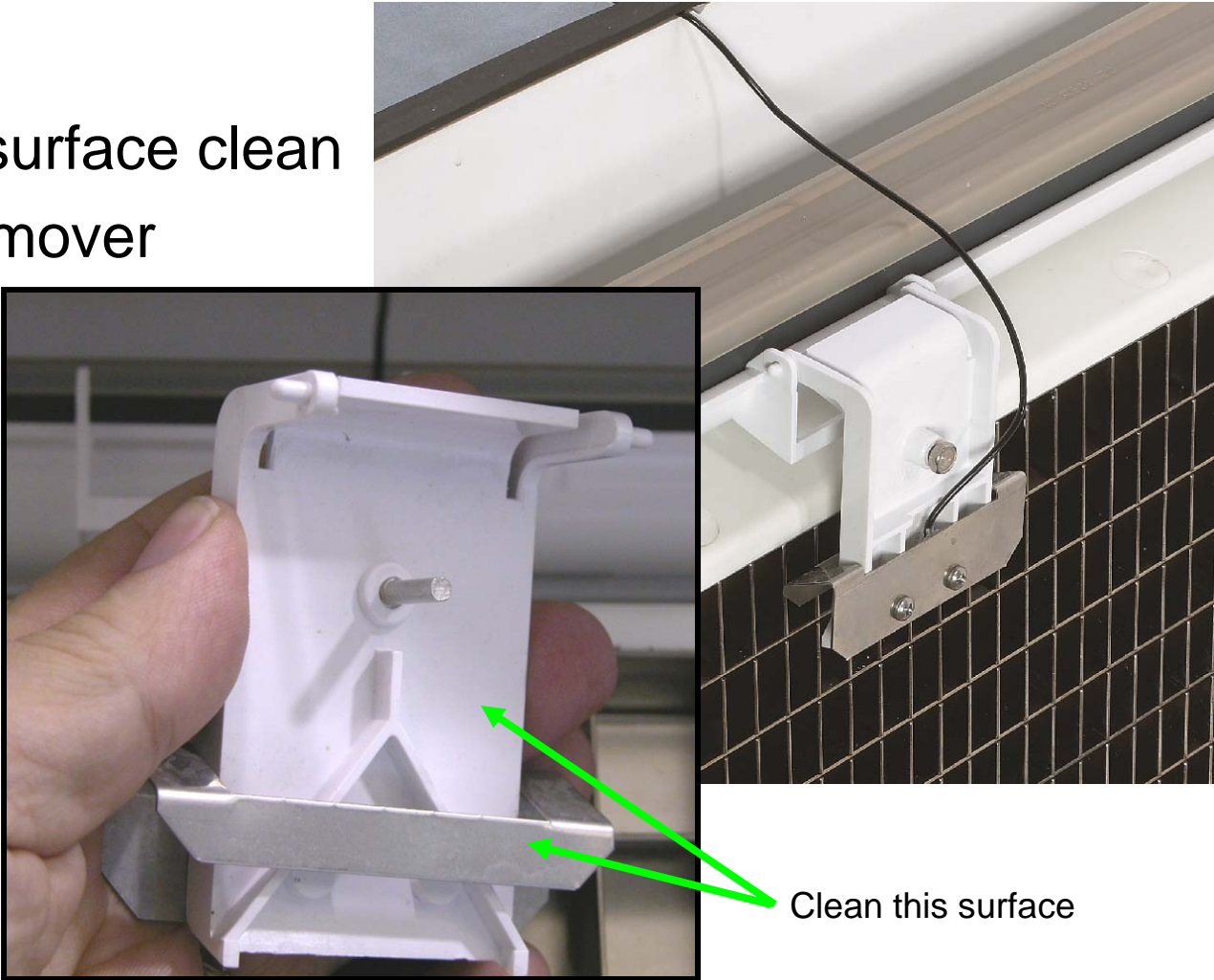

Clean this surface



## Water Level Sensor

- No tools required to remove
  - Release snaps and pull out
- Wipe metal probes clean with scale remover
  - Include base of plastic housing
  - White housing must be clean

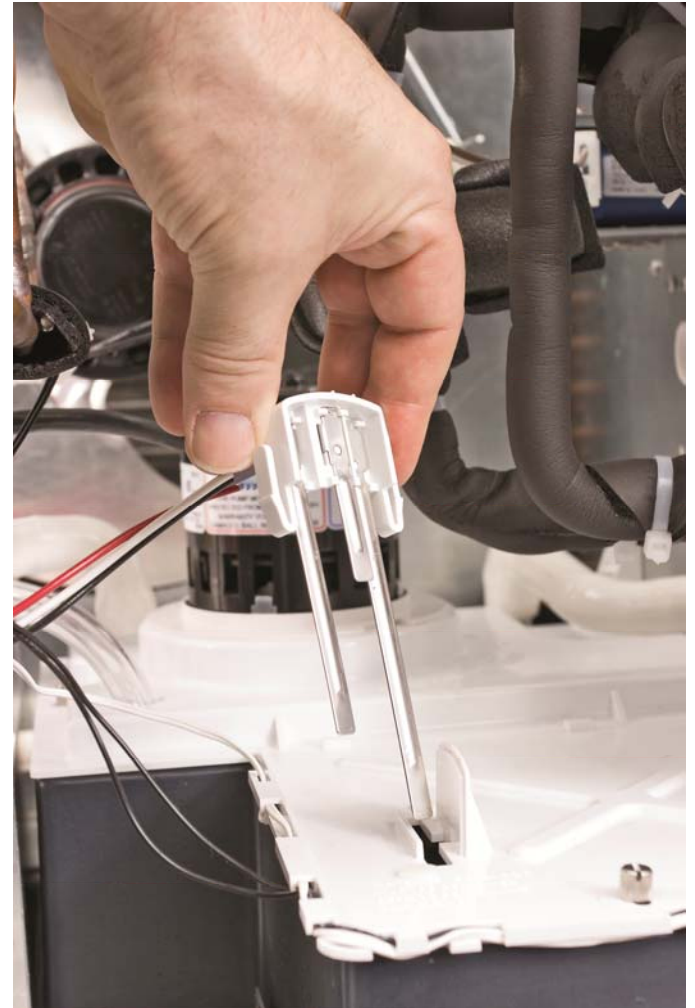

# C2648 Removable Sump



## Air Filter

- Slide out, wash off, return.
  - One filter up to 600 lb.
  - Two filters from 800 to 1000 lb.
  - Four filters 1400 lb and higher



# Cuber Service and Updates

## Service Notes: Service Controller

- Discharge static electricity by touching metal cabinet before touching controller
- Selector switch on replacement controller
  - Rotate to correct model per supplied instructions
  - Current number 11-0550-28

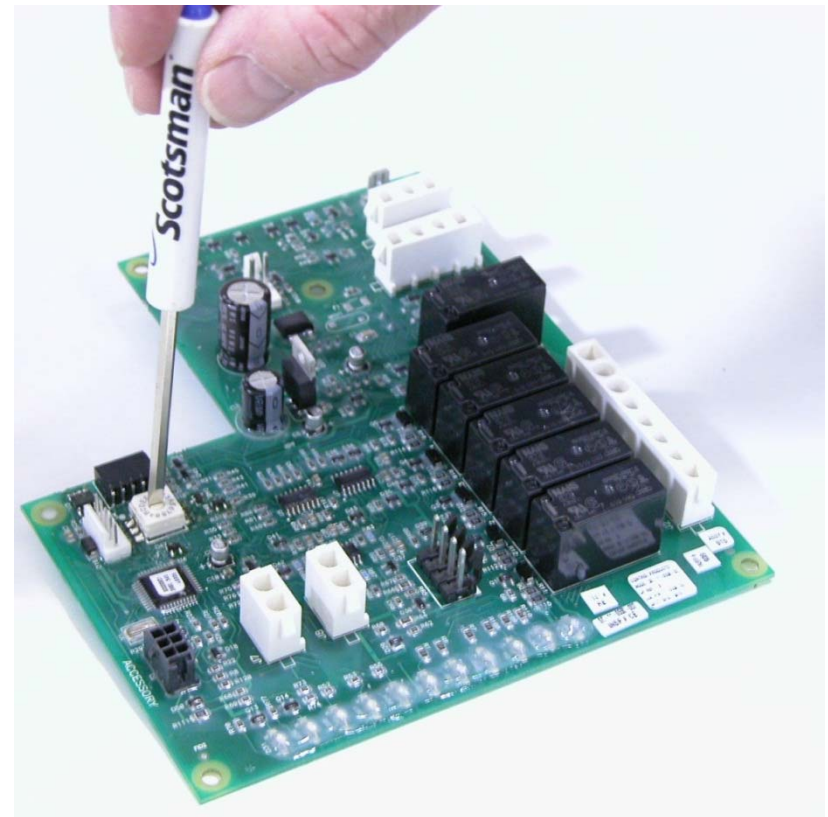

## Service Notes: Refrigerant Charge

- Ice machines are critically charged
- Refrigerant leak symptoms are progressive – they change as the amount of refrigerant lost increases
  - Thinner ice at evaporator area near tube outlet
  - Longer cycle times, both freeze and harvest

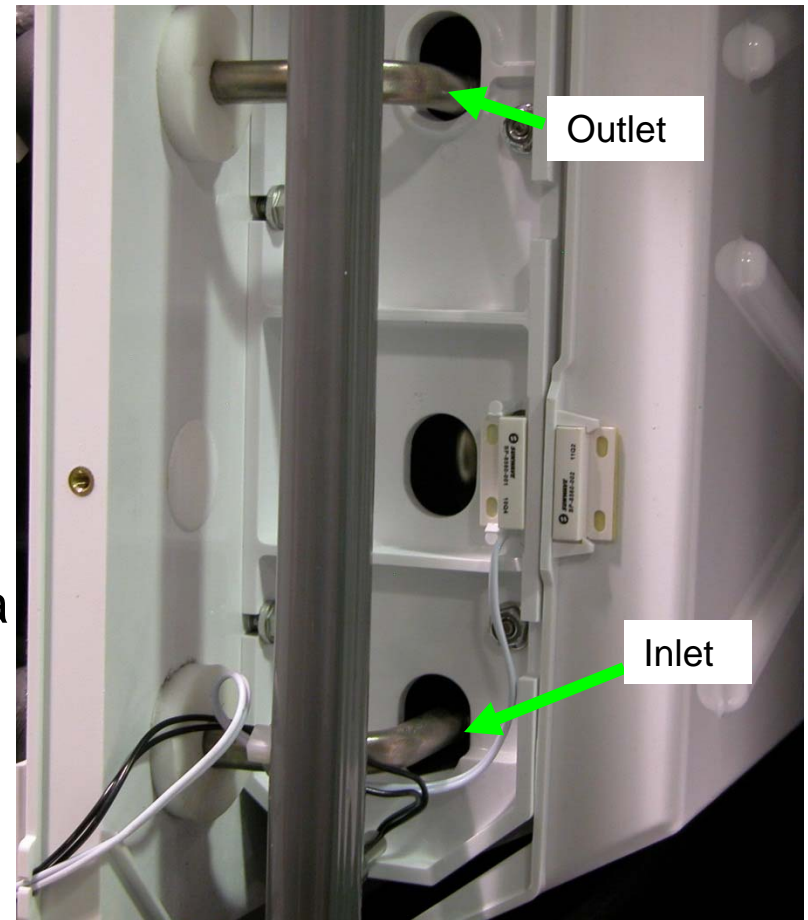

# Service Notes – Important Changes

- **Controller**

- Mid 2008, Rev 4: Auto-selects sensitivity between RO or low TDS water and standard water
  - Applied to Water Level Sensor
- Late 2008: Sensitivity also applied to Ice Thickness Sensor
  - Revs 5 and 6
- Early 2010, Rev 7:
  - Controller auto selects sensitivity for both water level and ice thickness and locks it in.
  - Sensing determined during first day's operation.
  - Can be / will be reset after a cleaning process is completed.
- Mid 2011, Rev 8: Service controller change:
  - 11-0550-28 – same as -27, except for C0530 C

# Important Changes

- Curtain

- All - bottom return made longer for better water containment
- Late 2010: Articulated curtain to reduce false bin full
  - Only for 18" evaporator size
  - C0830, C1030, C1448, C1848, C2148, C2648, EH222, EH430
  - Part Number 02-4611-21
  - EH222 retrofit kit A39843-001





## EH222 – New Curtain



Lower  
Section  
Pivot  
Point

EH222 Drip  
Stop

# C0830 thru C2648 – New Curtain

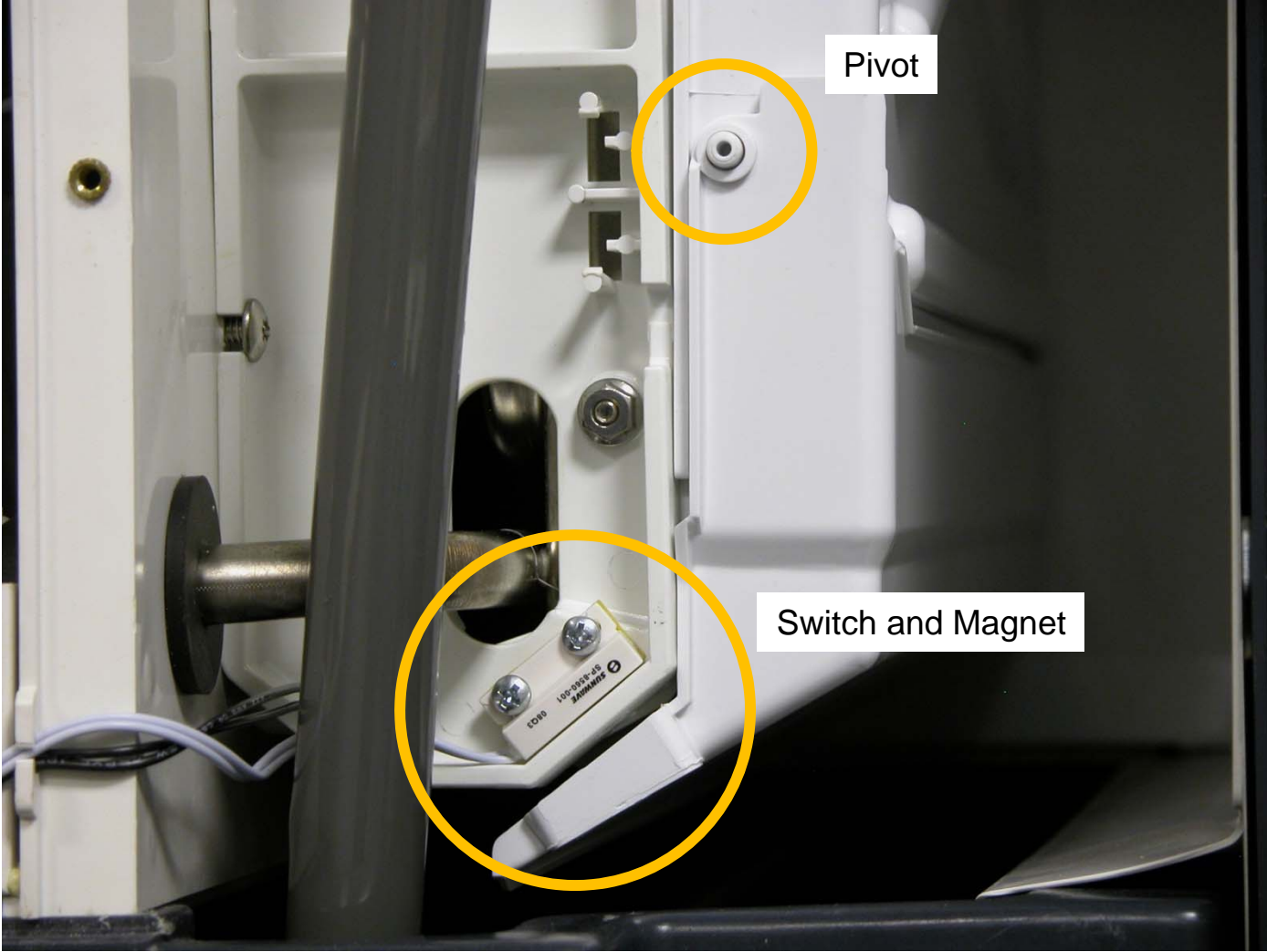

Pivot

Switch and Magnet

## Late 2011: New Water Level Sensor Guard

- Water level sensor probes shielded from water splash and separated from air upflow
  - Guard surrounds probes
  - Reduces false sump full signal
    - Reduces code 1 and 2 shut downs
- Applied to all Prodigy modular cubers
- Kits available:
  - Include sensor, harness, guard and sump cover



# Water Level Sensor Guard Kits

C0322, CB/C0522	CB/C0330, CB/C0530, CB/C0630, CB/C0830, CB/C1030	C1448, C1848, C2148, EH330, EH430	EH222	C2648
A39989-021	A39989-022	A39989-023	A39989-024	A39989-025

## Other Updates

- Expansion valve change:
  - C0322, C0330, C0522, C0530, C0630
    - To Danfoss
- Compressor change:
  - C0330 C series
  - C0530 C series
    - Both to Copeland RTS type
      - Improved energy rating, internal relief valve
    - Controller part number change to 11-0550-28
- Ice thickness sensor color change
  - Dark gray, easier to see scale
    - No part number change

# Flaked and Nugget Overview

- Modular models
  - Air cooled, water cooled, remote air cooled
- 22" wide platforms
  - Two cabinet heights – 23 and 27 inch
- Common look and operation across models
- Front service access to most components

## Cabinet

- 22 inch width
- 23 or 27 inch height
- 24 inch depth
- Reinforced base
  - Drop zone position changed
  - KVS sensor mounting socket included
- External air filter
- Optional air baffle

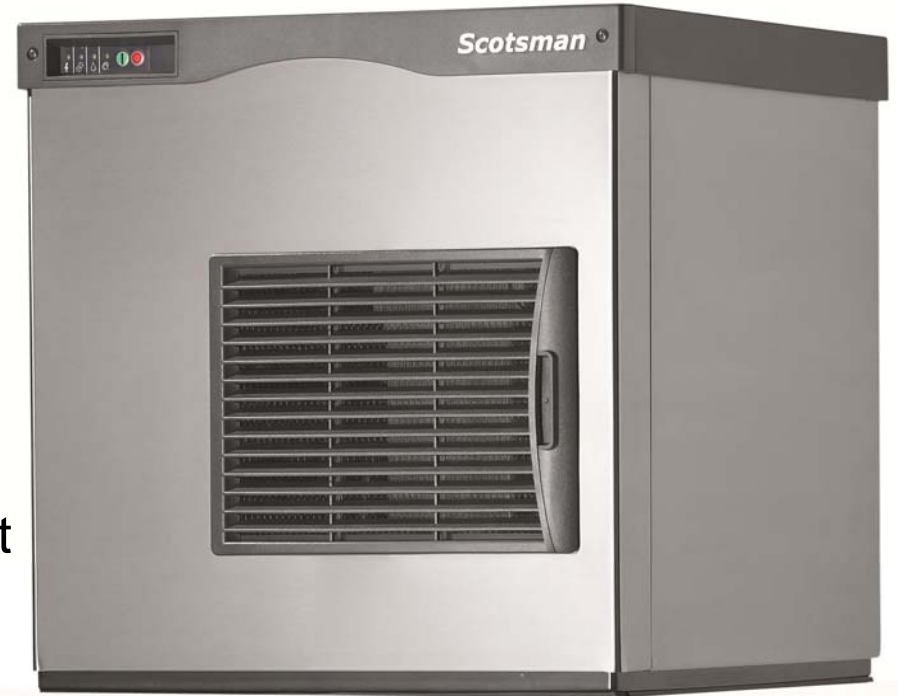

# NB and FB models – Prodigy Advanced Sustainability

- FB1222, NB0622, NB0922 and NB1322
- Air cooled only
- Fully Featured, includes all standard Prodigy features plus:
  - Ultrasonic ice level control
  - Information Display

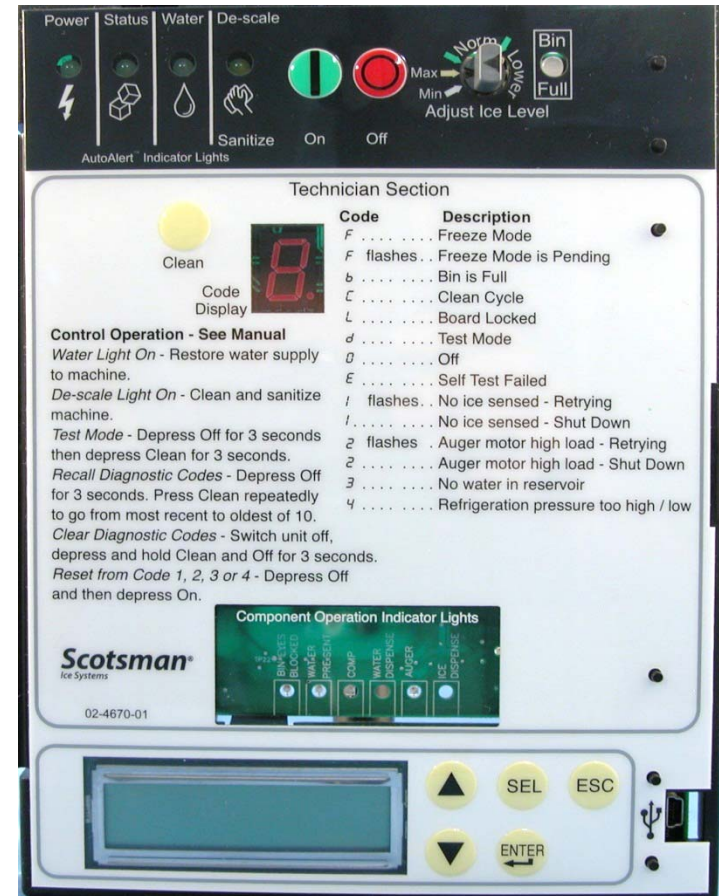



## Quick Review: What is a flaker?

- A continuous flow ice machine
  - Vertical, water filled, refrigerated cylinder
    - With internal CCW 11 RPM auger driven by a gear reducer
  - Constant water in and ice flow out
  - Ice crystals continuously form in the evaporator
    - Forced up by the auger and squeezed out thru slots or holes
  - Makes flaked or nugget ice by an extrusion process
    - Flaked ice: 6 large slots to push ice thru
    - Nugget ice: 16 holes

# Components

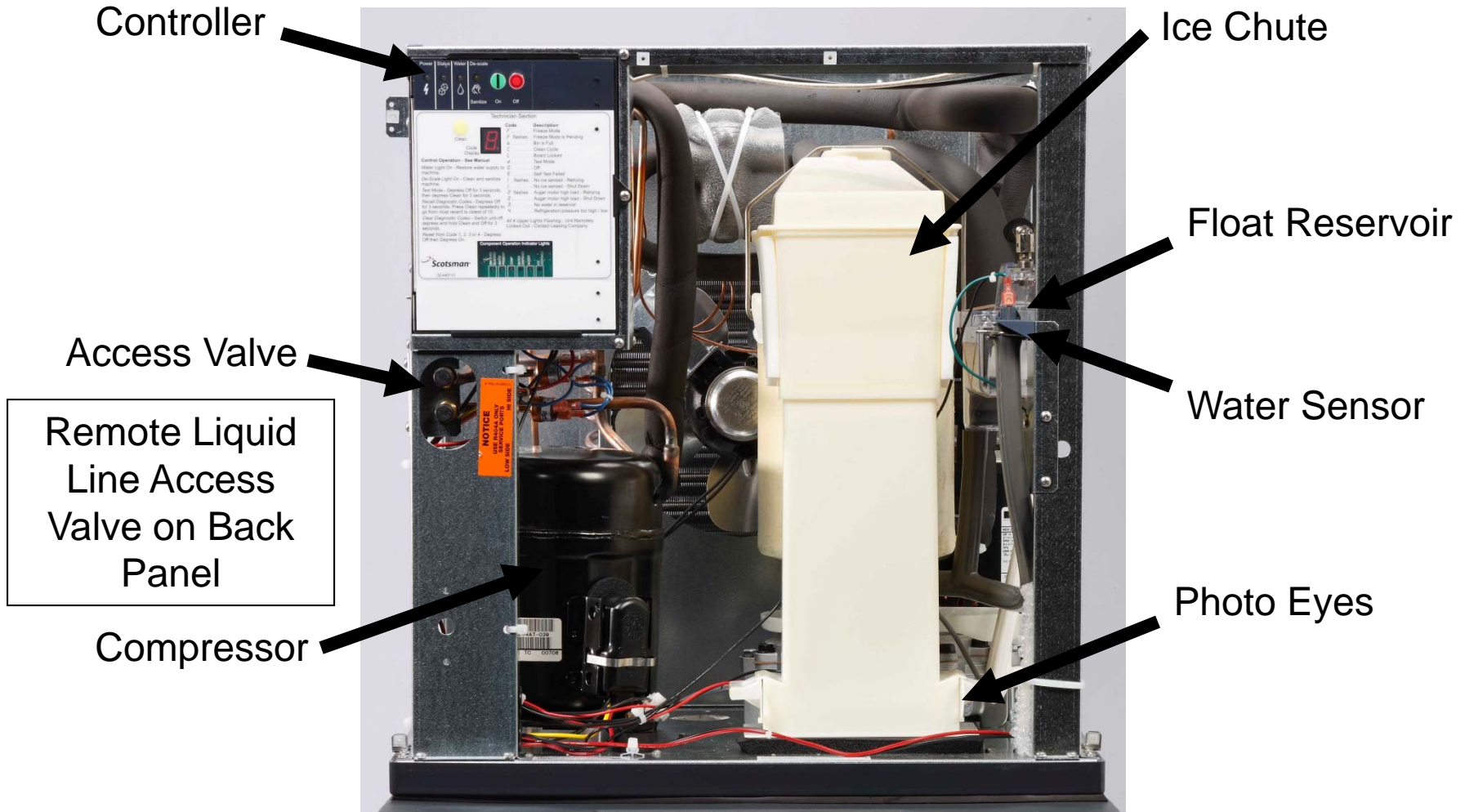

# Scotsman Prodigy Flaker

- Operated by an electronic controller
  - Controls compressor and auger motor
  - Senses ice, water, system pressure switches

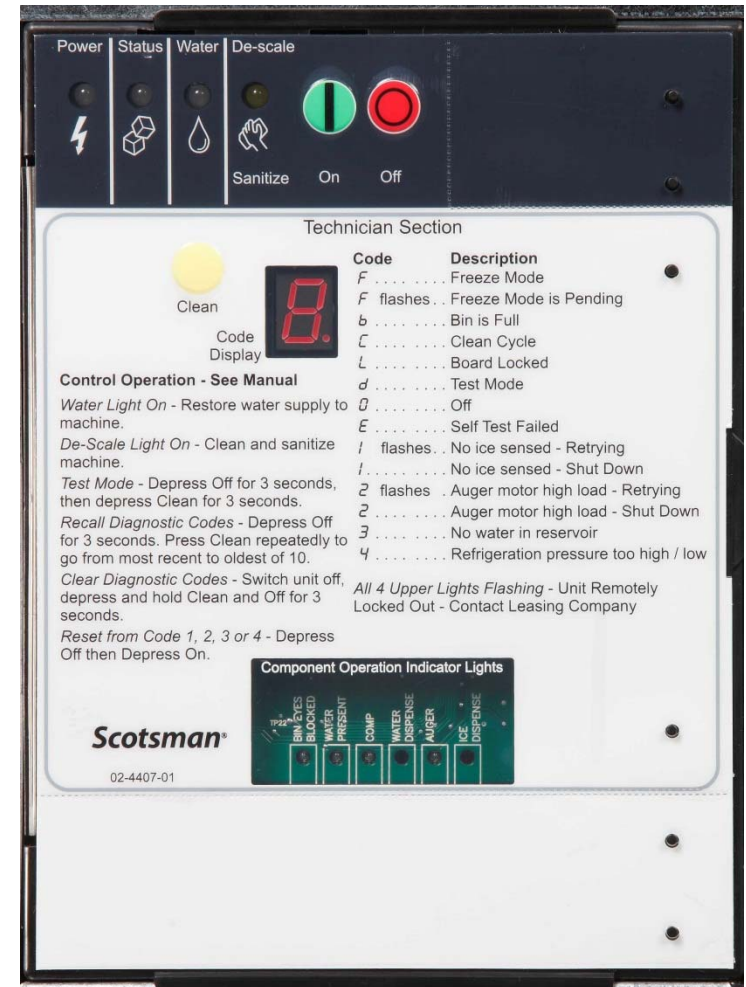

# Component Indicator Lights

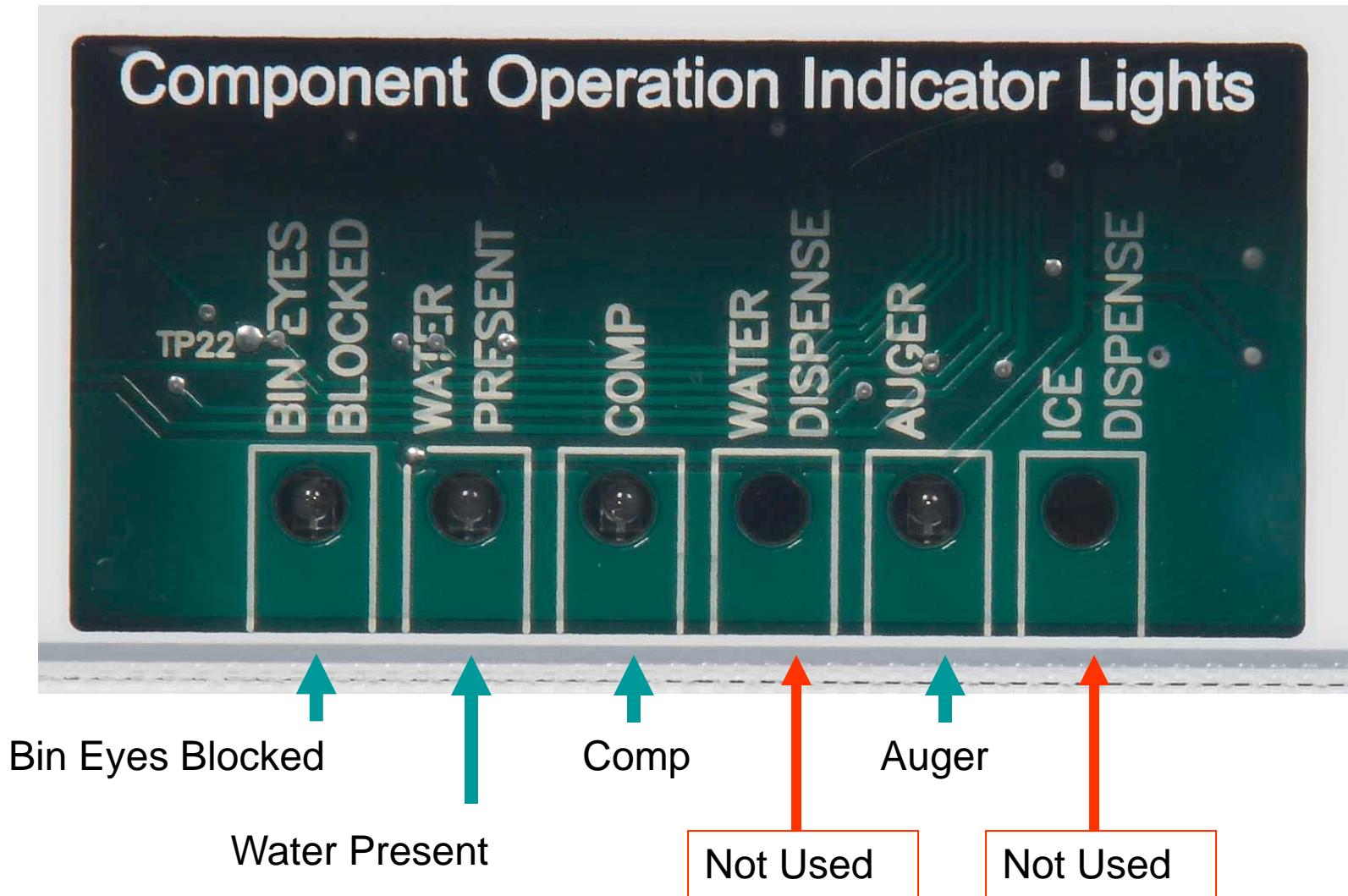

## Model Line Up

- F = Flaker, N = Nugget. Example: N0422A-1A
- 04 thru 15 = ice capacity in 100s of lb
- 22 = cabinet width
- A = air cooled, W = water cooled, R = remote, L = low side
- Voltage:
  - -1 = 115/60/1
  - -32 = 208-230/60/1
  - -3 = 208-230/60/3
  - -6 = 230/50/1

## Prodigy Remote Flaker / Nugget

- Use condensers
  - ERC111 – N0622 and F0822
  - ERC311 – all others
- Head change only: re-use prior condenser
  - Must be same refrigerant
  - Add headmaster kit KPFHM



# Control System

- Prodigy AutoAlert lights
  - Power, Status, Water, Cleaning
- Component indicator lights
  - Compressor, Auger Drive, Water, Photo Eye
- Cleaning mode
- Test mode
- Water sensor
  - Use RO water to 10 microSiemens/cm conductivity (~ 7 PPM)
- AutoSentry Plus: Enhanced with No Ice Sensed, auto voltage detection & amp trip setting

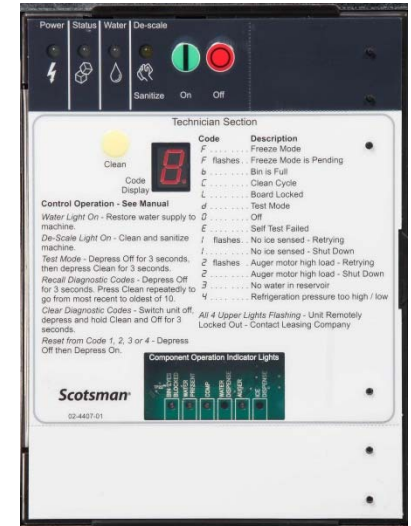

# Flaker Operation



# Start Up

- Push and release the On button
  - F code displayed
  - Status light ON
  - Auger drive motor will power up
  - Compressor will power up
    - Fan motor operates with compressor



# Electrical Sequence – Start Up

- Pre-start
  - Ice sensor sees empty chute (call for ice)
  - Water sensor has conductivity at probes (water OK)
- On button push starts unit
  - Auger motor starts
  - Compressor and fan motor start
- Controller checks for ice falling
  - Check begins 6 minutes after a restart
  - Must sense ice in a 10 minute span or shuts unit down (Code 1)

## Electrical Sequence – Shut Down

- Infrared light to photo eye receiver blocked by ice in chute
- Signals controller to shut down
- Controller shuts off compressor (AC or WC) or liquid line valve (RC or RL)
- Auger motor operates for 60 seconds to clear evaporator of ice
- Remote will pump down until low side pressure drops below 15 PSIG.

## Bin Control Methods

- Standard: Photo eye set
  - Infrared emitter and receiver at base of chute
- Optional: KVS
  - Control and sensor
  - Sensor mounts in base of unit
  - Ice level is adjustable
- Optional: Bin stat (opens on temperature fall)
  - Mounts to control box strut
  - Connects to blue wires in control box

# Power or Water Interruptions

- Power supply lost and restored
  - Automatic restart
  - 4 minute delay to restart
  - F code blinks until unit starts
- Water supply lost and restored
  - Automatic restart
  - 4 minute delay to restart

# Water Schematic

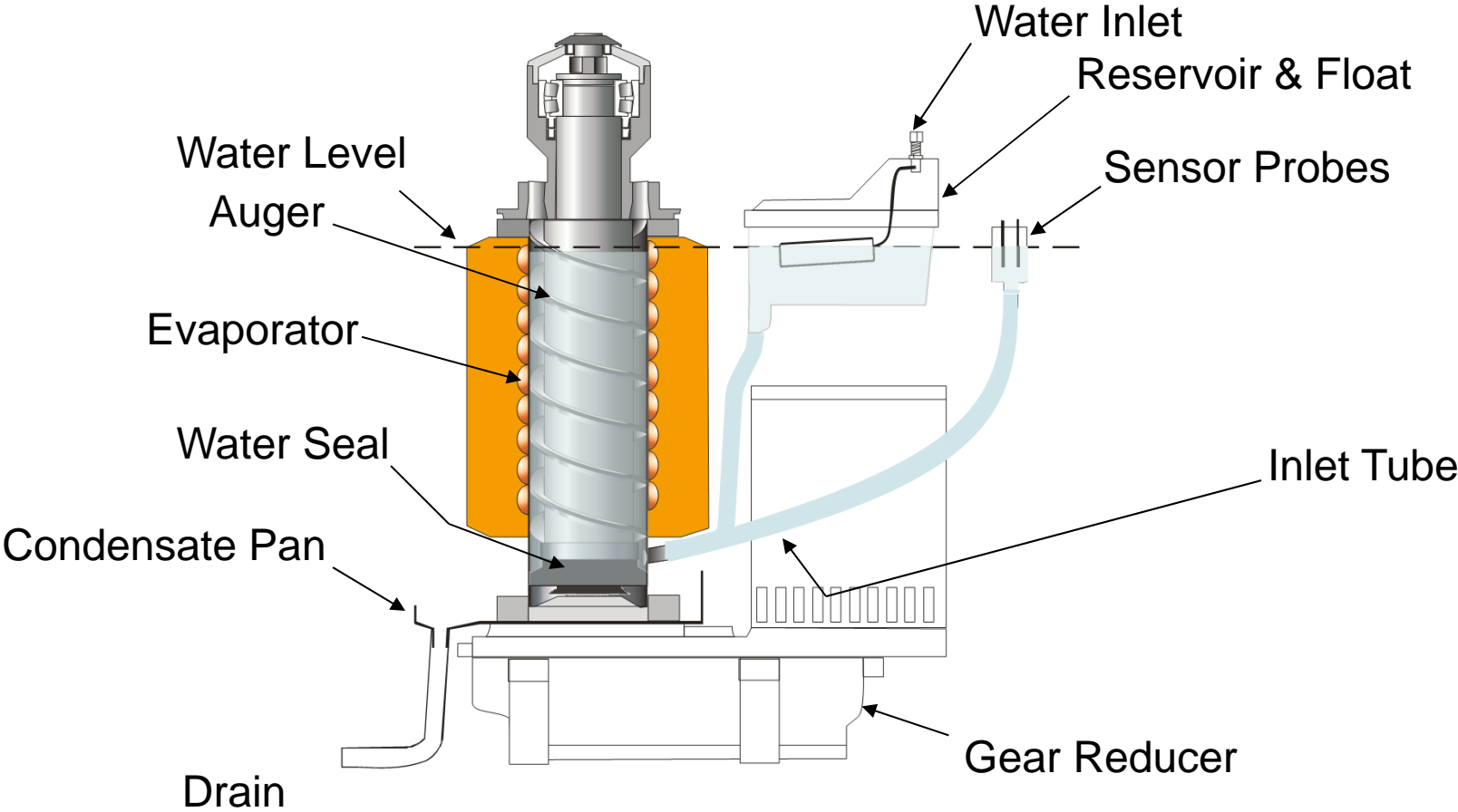

# Refrigeration Schematic, Air Cooled

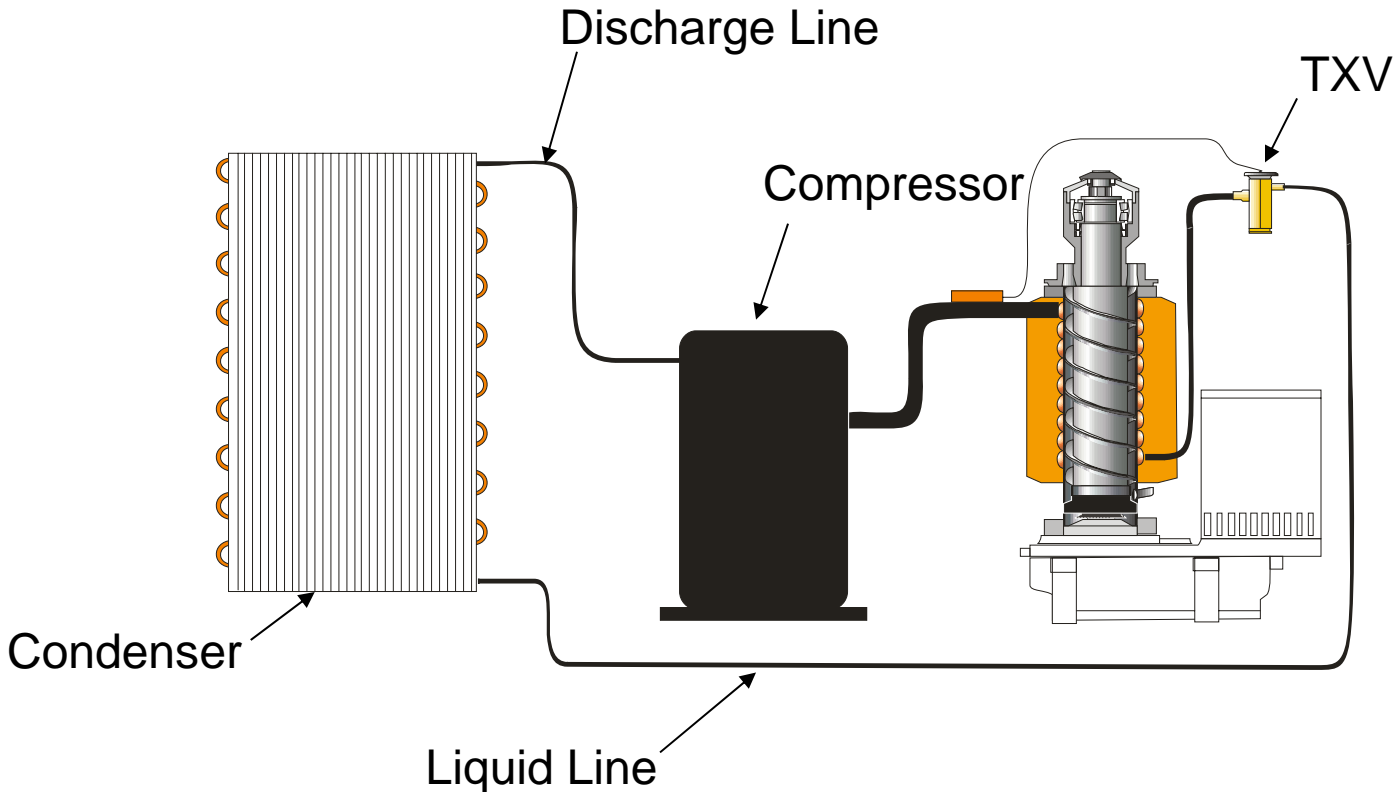

# Refrigeration Schematic, Remote Air

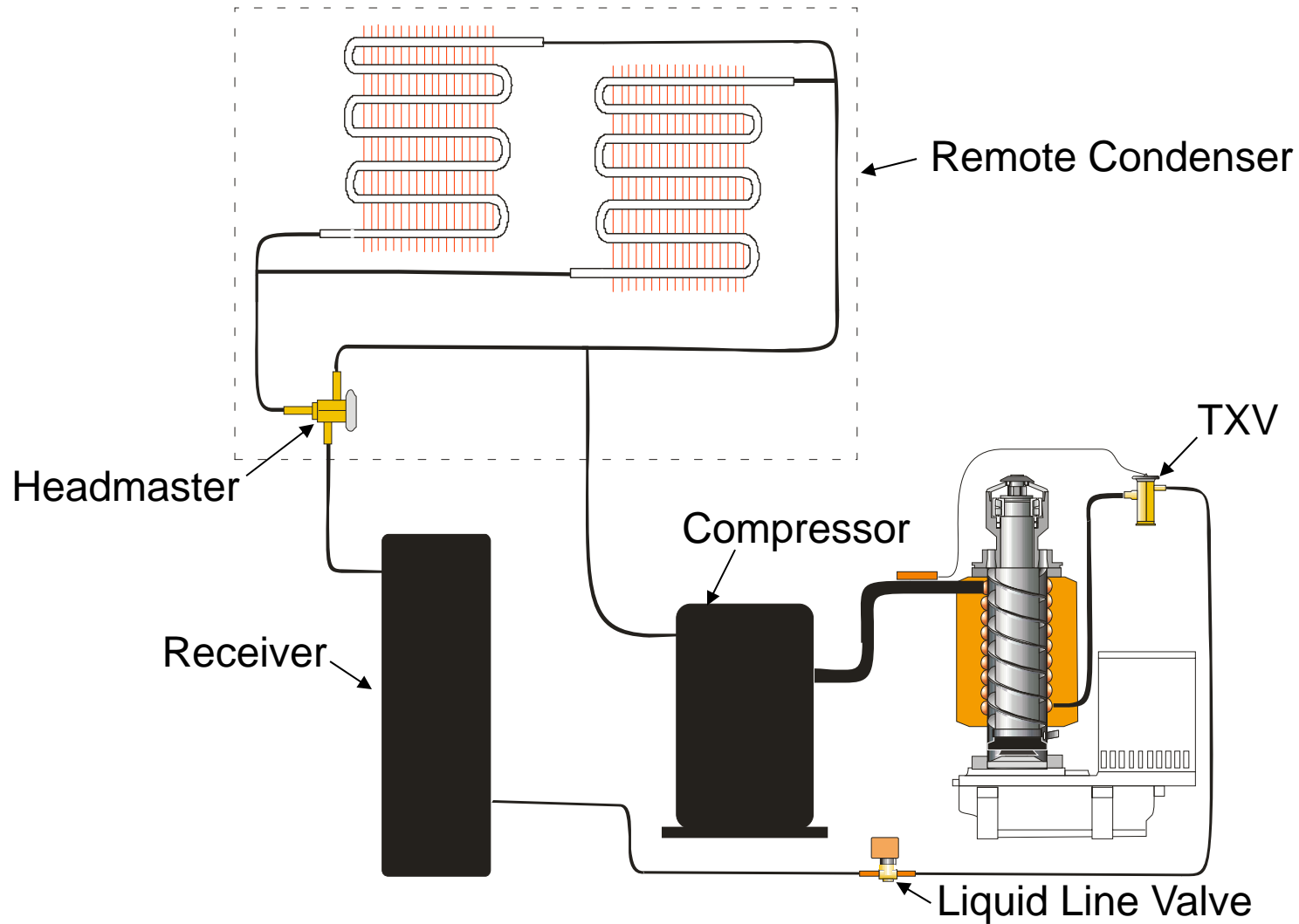



# Refrigeration Schematic, Remote Low Side

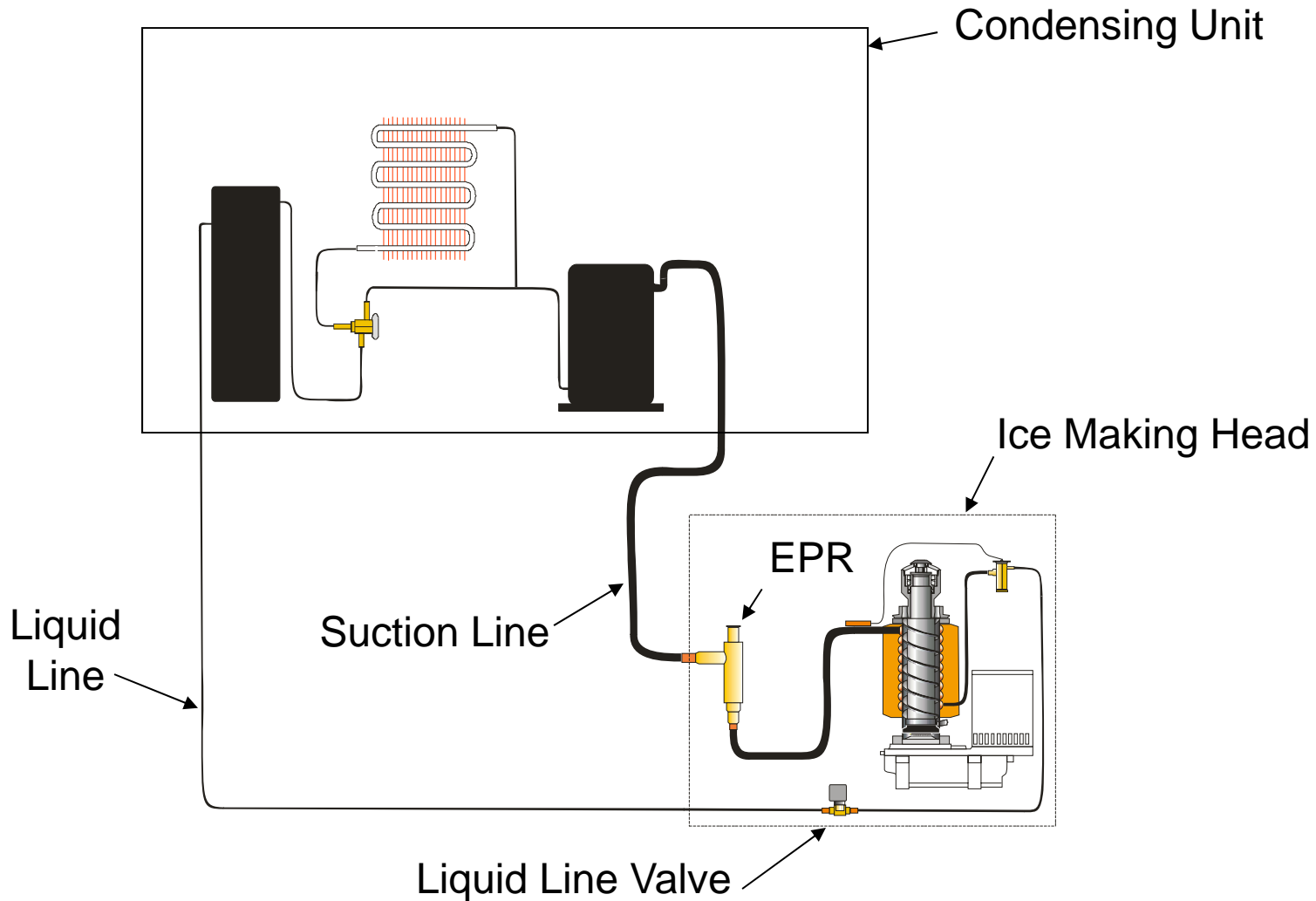

# AutoSentry Plus

- AutoSentry monitors auger motor current
  - Overloaded motor draws more current
  - High current triggers shut down
  - Code 2 displayed
  - Retry in 4 minutes
  - 2 restart attempts to manual reset
- AutoSentry Plus adjusts the current cut out point based on the voltage supplied
  - Example, at 115 volts supply voltage, the cut out point is 6 amps; 230 volt cut out point is 3 amps

# Display Codes

- F = Freeze mode
- b = Bin full
- C = Clean cycle
- L = Locked
- d = test mode
- O = Off
- E = self test failed
- 1 = No ice sensed
- 2 = Auger motor over amp
- 3 = No water sensed
- 4 = Refrigeration system pressure too high / low

A blinking code means a mode change – will restart or has restarted

# Flaker Maintenance

# Maintenance – Recommended Every 6 Months

- Water System

- Scale removal

- Shut off water
    - Drain reservoir
    - Cover photo eyes to protect from spills
    - Mix 3 quarts hot water to 8 ounces Clear 1 scale remover – do not NOT pour in undiluted!
    - Fill reservoir – and keep full until all solution is used, then turn water on



# Maintenance

- Check mechanicals
  - Clean air filter
  - Clean Water Sensor
  - Ice Sensor
    - Clean eyes
  - Top bearing
    - Check / Repack
  - Water seal
    - Check condensate pan
  - Gear reducer bolts
    - Check torque
      - 275 inch pounds

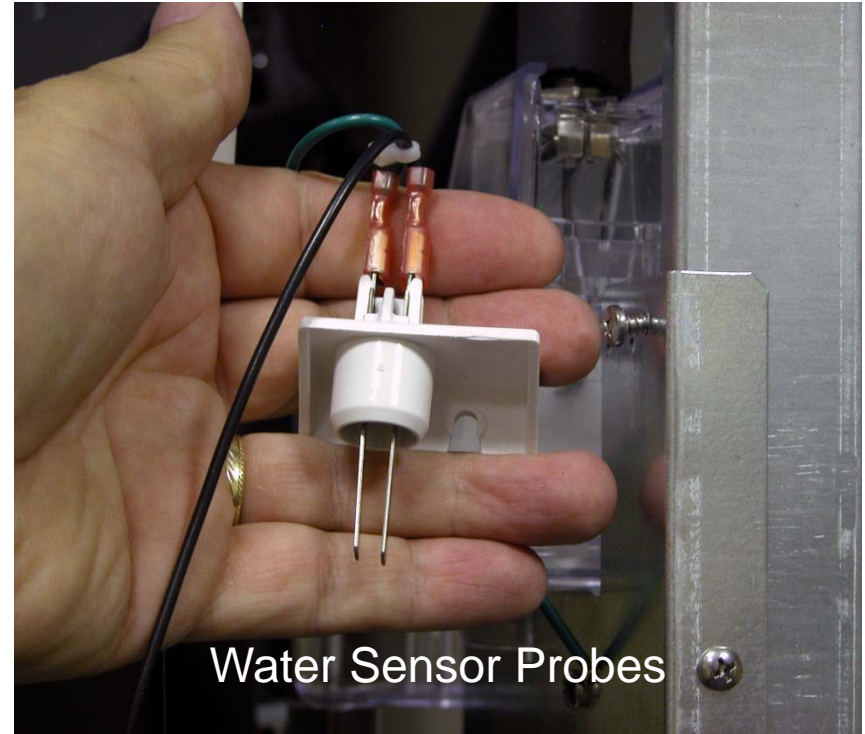

Water Sensor Probes

# Maintenance – Scale Removal

- Clean mode
  - Push Clean button
  - Timed soak / auger in motion – 20 minutes
  - Timed run / ice making – 20 minutes keep reservoir full of solution
  - Resets clean light



# Maintenance

- Clean ice sensors
  - Photo eye set
  - Slide out to remove
  - Wipe with diluted ice machine scale remover





## Bearing Access

- Push bail clamp back
- Remove chute cover
- Remove ice sweep
- Remove breaker cover
  - Left hand threads



# Maintenance

- Bearing service
  - Grease all white – OK
  - Grey streak – add grease to check
  - All grey - repack
    - Repack with grease needle
- Replacement
  - Use arbor press to remove and press in new bearing



# Maintenance

- Water Seal

- Check condensate pan
- Water seal leak drains into pan

Condensate Pan

Drain Slot

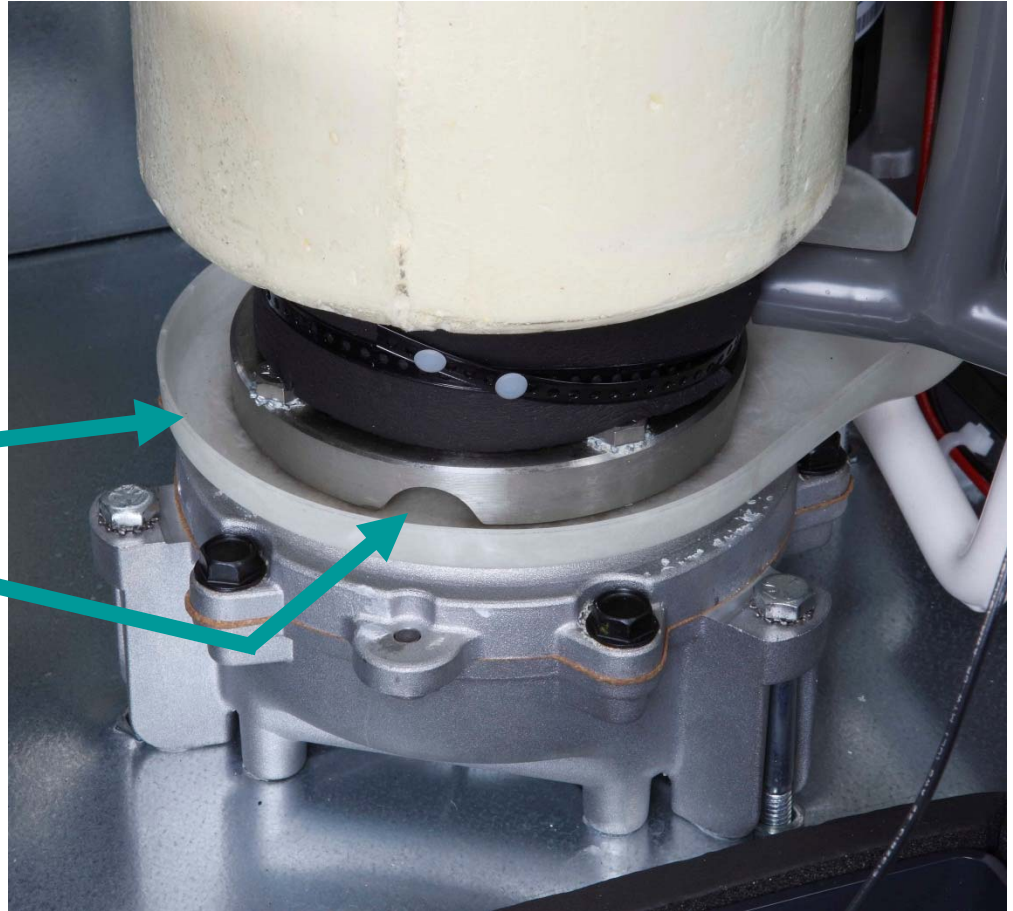

# Flaker Diagnostics

# Diagnostics

- Code 1: No ice sensed
  - Rule out: high or low pressure cut out (Code 4)
  - Rule out: no water (Code 3)
  - Auger motor over amp (Code 2)
  - Check:
    - Excessively hot conditions – restricted air flow
    - Dirty air filter or condenser
    - Lack of refrigeration – charge, expansion valve, fan motor, headmaster

# Diagnostics

- Code 2: Auger motor overloaded
- Auto restarts 2 times
- 4 minutes between restarts
  - Check
    - Motor condition
    - Liquid line valve for leak thru (remote low side)
    - Scale on evaporator & auger
    - Bearing condition
    - Gear reducer condition
    - Compressor contactor sticking
    - Low pressure control (remote pump down) not opening

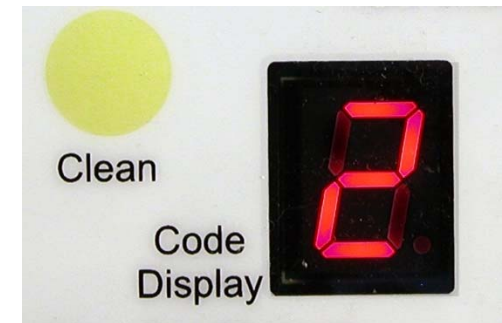

# Diagnostics

- Code 3: No water in reservoir
  - Check filters
  - Check float valve
  - Check sensor
    - Two-Probe Sensor in leg of hose to evaporator
    - Test: short probes together
      - Turns indicator light on
      - Space between probes turns light off

Probes



# Diagnostics

- Code 4: High or Low Pressure Control Open
  - Pressure controls are automatic reset type
  - Code 4 indicates one of them opened
    - Unit off, Code 4 means one is still open
    - Unit on, Code 4 in recall code list – was open in past
  - Restart unit to check
    - High (Cut Out 450, Cut In 350):
      - Water cooled may be water interruption
      - Air cooled may be fan motor
    - Low (Cut Out 15, Cut In 30):
      - TXV restricted
      - Charge too low
      - Auger motor or auger not turning



# Controller Button Process

- Reset controller
  - Push Off, then On
- Recall Diagnostic Codes
  - Hold Off button in for 3 seconds
  - Push Clean button to cycle thru the stored codes
- Clear Diagnostic Codes
  - From Standby – Status Light OFF
  - Push and HOLD Clean and Off buttons for 3 seconds

# Diagnostics

- Unit off, **b** in code display, bin is not full
  - Check “Bin Eyes Blocked” indicator light
  - Scale on photo eyes, clean and recheck
    - If clean and Bin Eyes Blocked light is ON, replace eye set
  - Photo eyes out of mounting slot
  - Ambient light on photo eyes
  - Photo eye failure
  - Optional KVS set too low or sensor out of socket
  - Optional Bin Stat is open

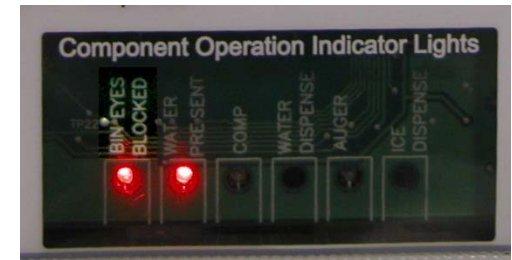

# Diagnostics: Refrigeration

- Low charge symptoms
  - High superheat
    - Normal is 10 - 15 degrees F. but varies with ambient
  - Overheated compressor
    - Note: Normal Tecumseh dome temperature is hot
  - Low ice making capacity
  - Low suction pressure
    - 400 - 500 lb normal is 37 - 40 PSIG – higher at high ambient
    - 600 – 800 lb normal is 32 - 36 PSIG
    - 900 lb + normal is 25 - 30 PSIG

## Diagnostics – Low Capacity

- Clean machine first
  - Scale build up will cut capacity
- Test by catching ice
  - Operate unit for 10 minutes prior to test
  - 15 minutes weight x 96 = 24 hour capacity
  - Low capacity units will be very low

# Flaker Service

# Service

- Remove the Auger
  - Shut off water
  - Drain reservoir & evaporator
  - Push bail clamp back
  - Remove cover
  - Remove ice sweep
  - Remove upper chute



# Service

- Loosen auger stud
- Remove 4 allen head bolts
- Lift Auger out, dry off
  - Works best clean & bright
  - Examine auger edges
    - Excessive bearing wear will cause auger damage
  - Check evaporator wall for scale
- Replace Water Seal



# Auger

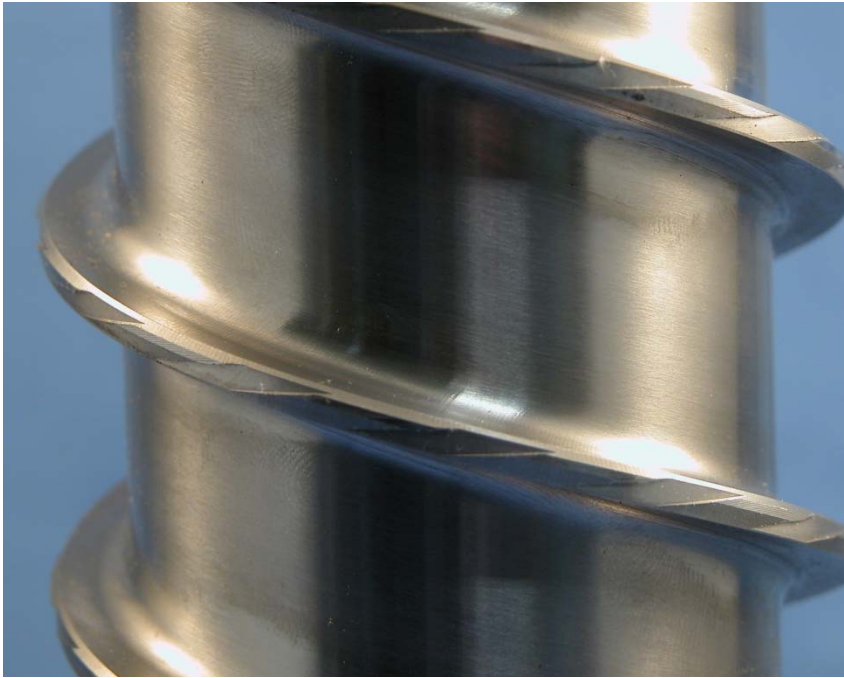

Auger as it should look,  
clean and not damaged.

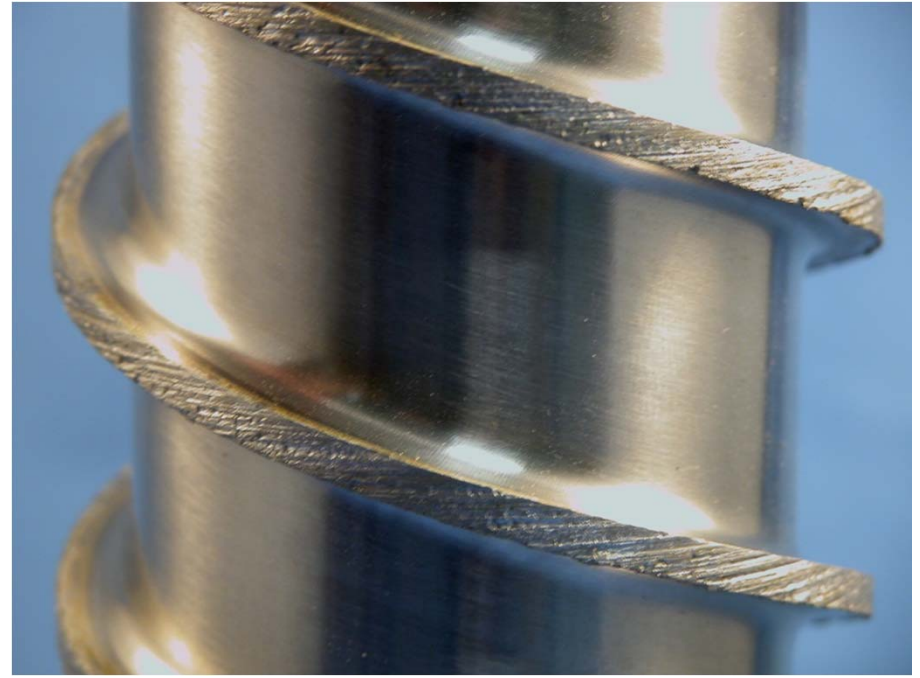

Damaged Auger –  
replace, do not use!



## Water Seal Replacement

- Remove auger
- Separate from gear reducer
- Remove retainer and stationary half of seal

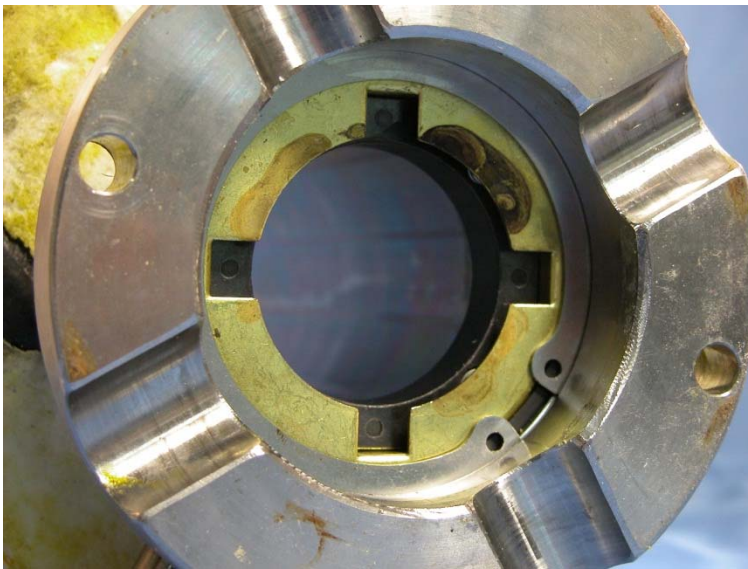
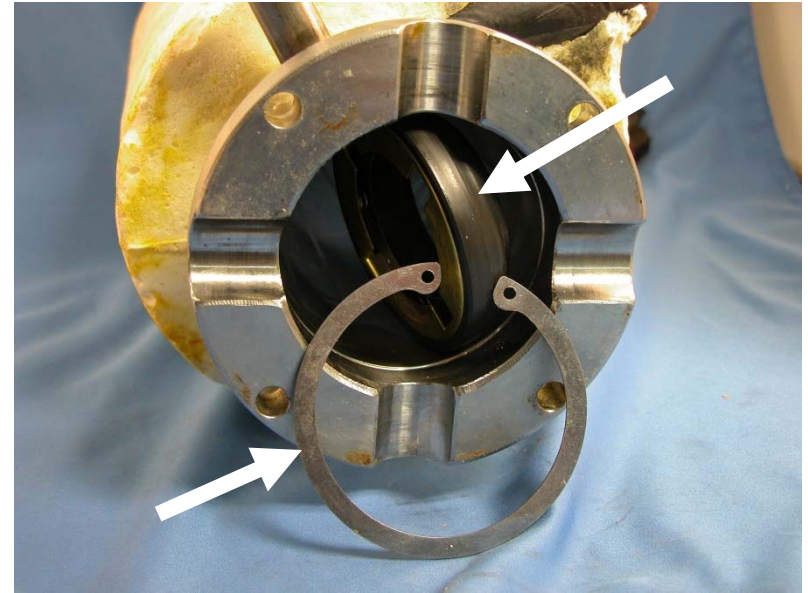

- Lubricate new seal half
- Insert seal into tube
- Install retainer
- Reposition seal onto retainer

# Water Seal Replacement

- Rotating Half
  - Clean auger shoulder
  - Add bead of food grade sealant to shoulder
  - Lubricate rubber
  - Slide onto auger
  - Sealant fills gap

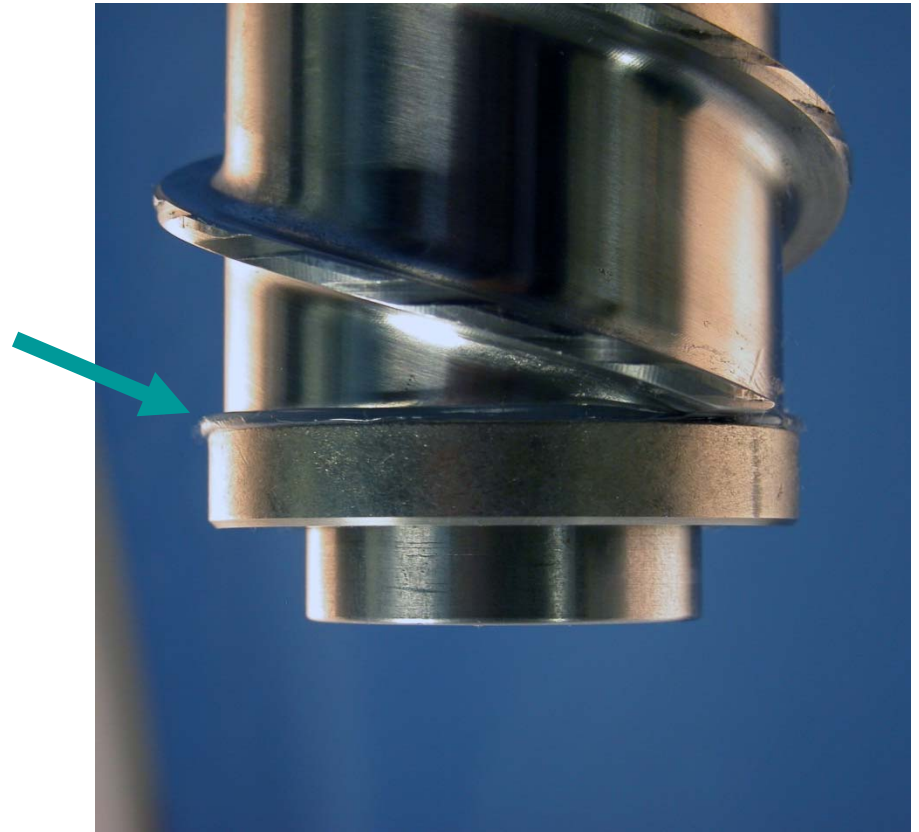

## Service: Top Bearing

- Remove auger stud
- Separate breaker from auger, check bearing
  - Remove / Replace bearing using arbor press
  - Install new lip seals, cup side up
    - 2" PVC coupling install tool
    - Lube seals with food grade grease before installing bearing



# Updates

- New Water Shed
  - Use began September 2011
  - Flexible area seals to output shaft
  - Rigid area remains flat
  - Part number 02-4663-01

Water Shed Sweep  
Feature



# Updates

- Water level change – F and N models only
  - Reservoir lowered by  $\frac{3}{4}$  inch
  - Began in June 2011
  - Do not lower water level in machines manufactured after that
- Compressor change to Copeland RST
  - F0822 and N0622 change to B series



# Prodigy Options

# Options

- Vari-Smart and Smart Board Standard on CB, NB and FB models.
  - Vari-Smart - KVS
  - Smart-Boards – Universal
    - KSBU, KSBU-N, TPD2
    - Works on all Prodigy Cubed, Nugget and Flaked ice machines
- Smart Lock – Remote lock out
- Front (cuber) or Side (flaker) air flow kits
  - Add / Change air filter location for specific applications
- Remote condenser air filter
  - KERCF for ERC111 and ERC311

# Field Installed Options

- Vari-Smart – Adjustable ice level control
  - Connects to existing controller
  - Adjustable to maintain a lower level of ice in bin or dispenser





# KVS

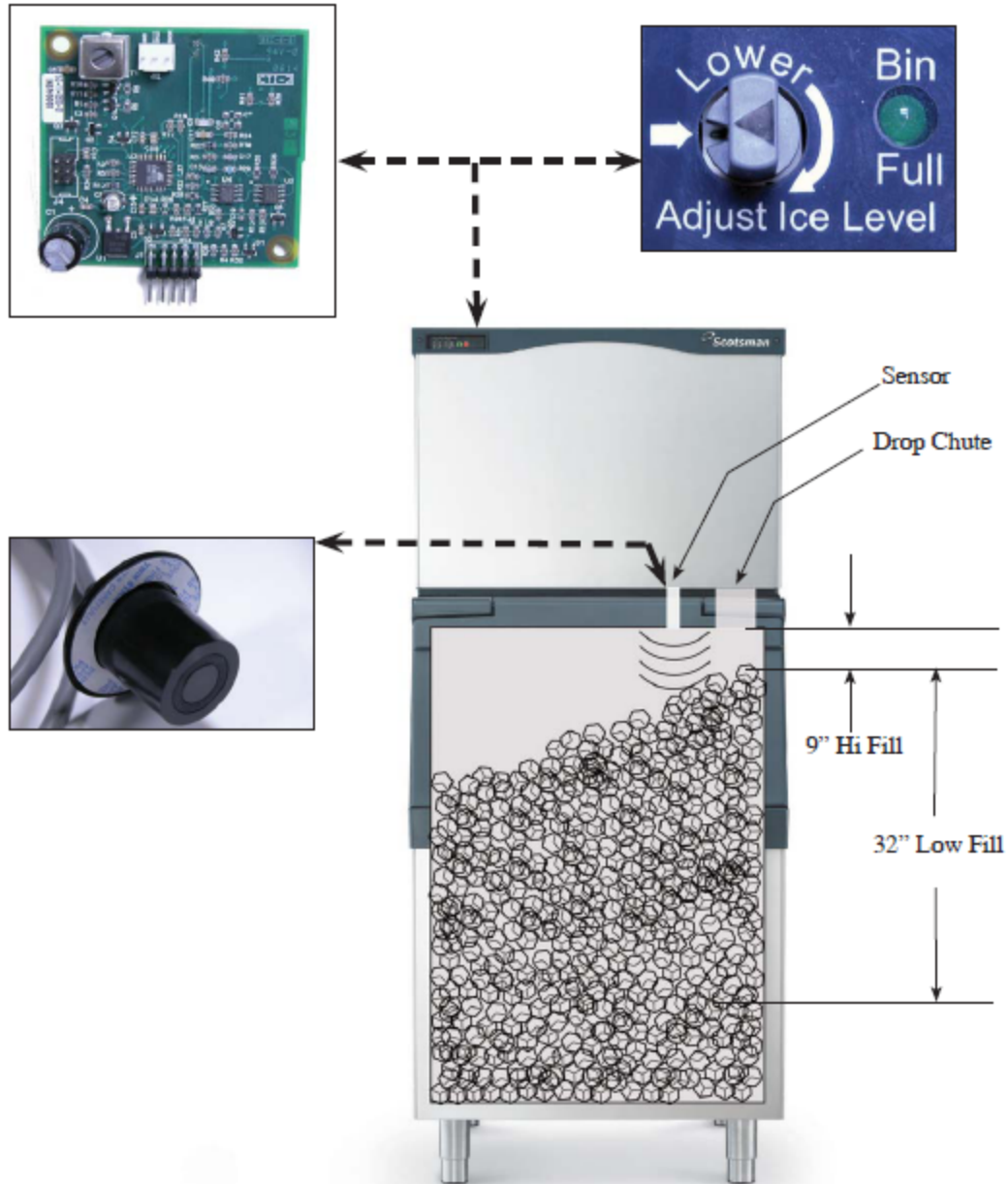

## Vari-Smart

- When the adjustment knob and decal arrows point to each other the unit shuts off on the curtain switch
  - Next setting CW is 9" from sensor to top of ice
  - Typical ice slope results in ice closer at the drop zone
- Adjustable lower
- 1" ice level differential between off and on

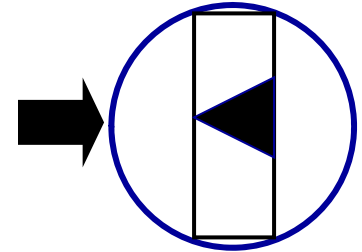

# Vari-Smart

- Recommended settings
  - Dispensers
    - 9 – 11 inches
  - Bins
    - Tall bins – any
    - Short bins – no lower than 16"
  - Do not set too low when on a dispenser or short bin
    - If too low, Vari-Smart will sense dispenser liner and keep ice machine off

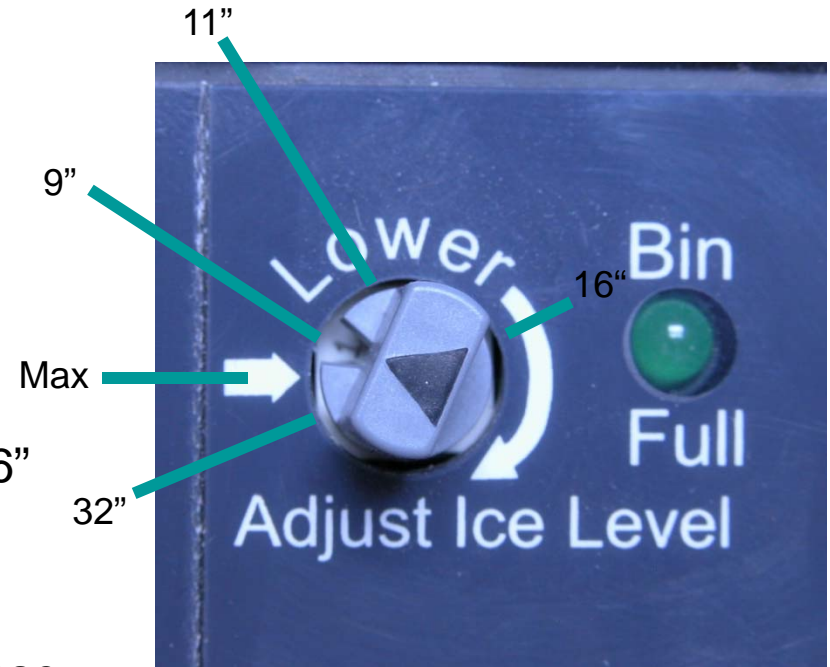

# Field Installed Options

- Smart-Board

- Available as an add-on to the existing controller or
- As a data logger that can be moved from unit to unit

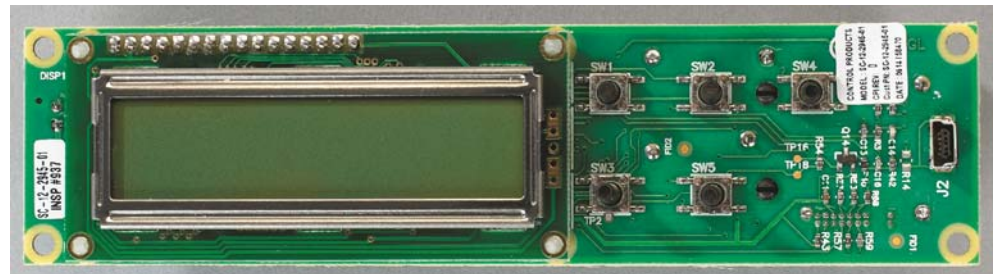
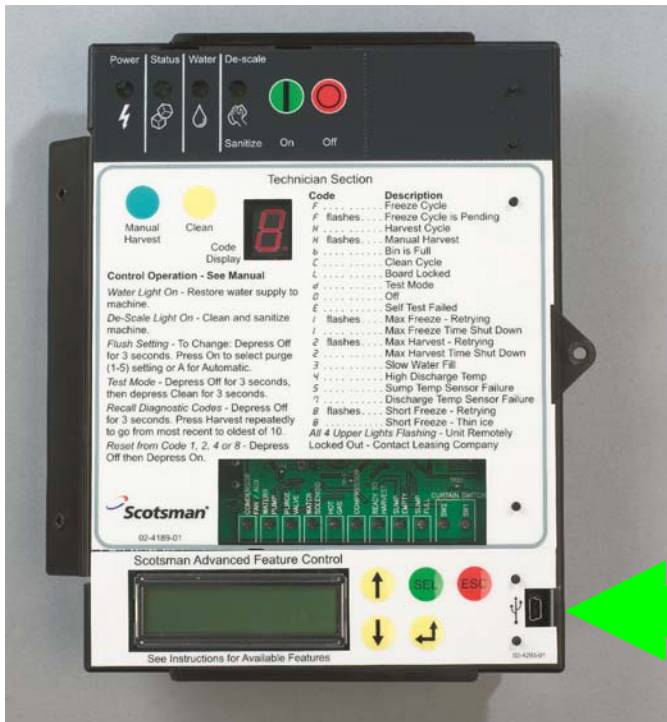

# Summary

- Prodigy
  - Efficient
  - Simple operation
  - Easy maintenance
    - Slide out air filters
  - Easy to diagnose
  - Operational Codes on unit
  - Common operation, common parts
  - High Tech Options

## Other Updates

- Bin Hinge Pin Change
  - June 2011
  - Chamfer added
  - Reduces friction when closing
  
- CU bin door change
  - August 2011
  - Bumpers added
  - Reduces impact when closing

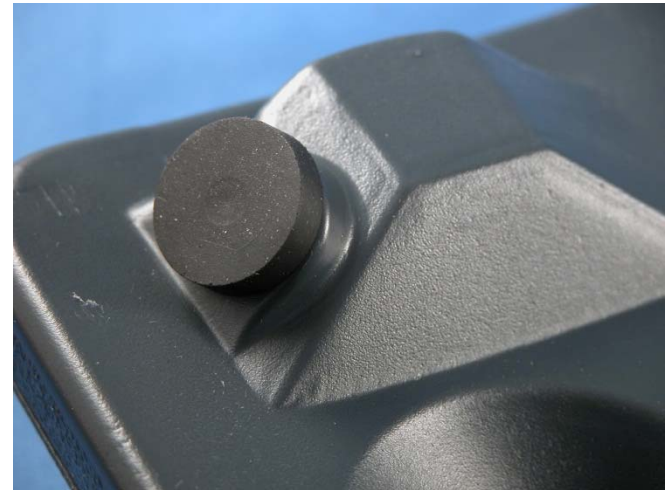

## Review – CM<sup>3</sup>

- No Ice
- Water in reservoir
- Two Blink Water Code
  - Code means Slow or No water fill; low water level
  - 4 Possible Causes:
    - Fills too slowly – restricted water supply
    - Water not high enough in sump
    - System did not sense full sump correctly
    - Water valve not opening



## CM<sup>3</sup> – Sump Fills Too Slowly

- Models up to 800 lb capacity: Controller allows 130 seconds to fill reservoir
  - About 1.5 GPM
  - Check water pressure
  - Check water filters



## CM<sup>3</sup> - Water Not High Enough

- Overflow Models

- CME256, CME506, CME656 or CME806
- Water drains out thru standpipe behind pump – Max water level is top of standpipe
- If standpipe is too low, or water leaking out, sump cannot fill high enough
  - Unit **must be level**
  - Correct setting is 2 and 5/8 inches from top of adjustment nut to top of sump wall

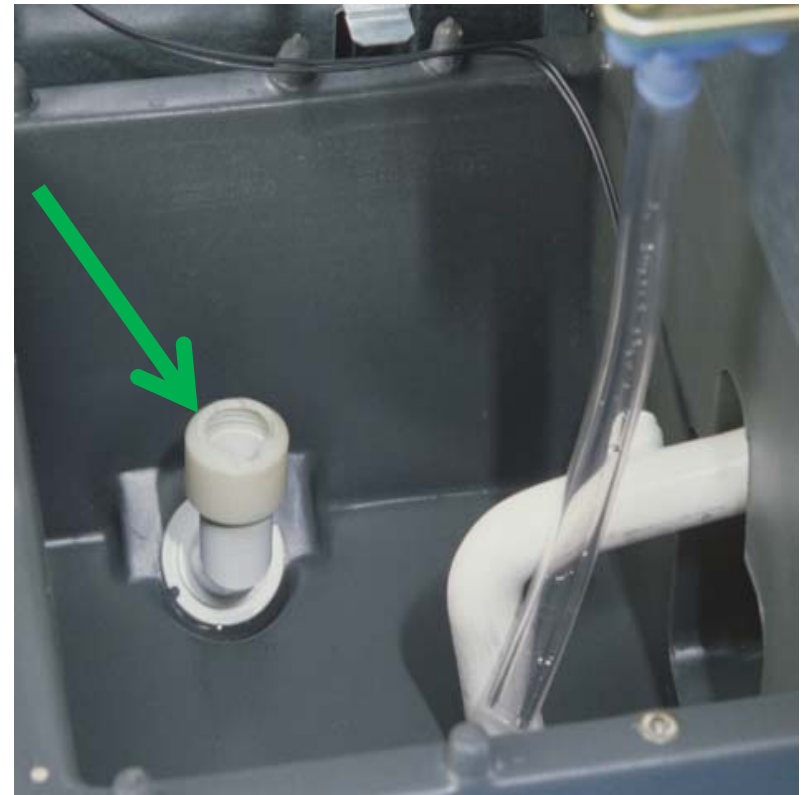

# Standpipe

- Measurement

- Height is factory set, should not need adjustment, but..
- Correct height is 2 and 5 eighths inches from the top of the standpipe adjustment nut to the top of the reservoir wall
- Set measuring device first, then adjust nut



Adjustment Nut

## CM<sup>3</sup> – not sensing water level – unit not starting

- Water Level Sensor and Float Stick
  - Rising water lifts float and stick
  - Slot in stick passes electric eyes
  - When bottom of slot rises and blocks bottom eye, signals Sump Full
- Test
  - **Must** have correct stick! Check PN
  - Lift stick slightly to simulate full sump
    - If unit starts, control system good but water level too low
  - Or test with DC voltmeter



# CM<sup>3</sup> Water Sensor Diagnostics

- Check voltage w/ DC VM
  - Controller must have power and be “alive”
  - a) Unplug harness from position 2, check voltage at top and bottom pins
  - b) Reconnect, check voltage again
  - Negative on yellow, positive on white, move float. Voltage should change
  - Positive on red, move float

	Black	Blue
a) Top to Bottom	24 to 30	.5 to 2
b) Top to bottom	2 to 3.5	.4 to 2
White to Yellow, blocked	5	5
White to Yellow, unblocked	<1	Less than when blocked
Red to Yellow, blocked	5	5
Red to Yellow, unblocked	<1	Less than when blocked

***Scotsman***<sup>®</sup>

**Scotsman**<sup>®</sup>  
Ice Systems