

Scotsman®

Installation and
User's Manual for
Flake and Nugget Ice Machine

Models FME504, FME804, NME454,
NME654

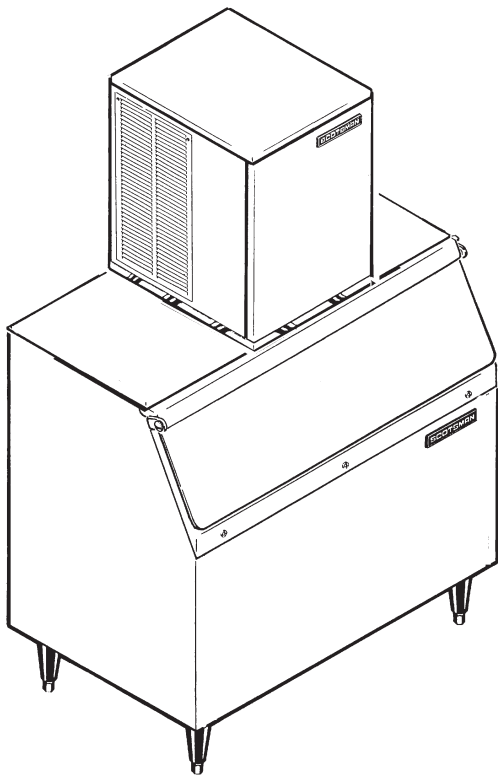

INTRODUCTION

To the owner or user: This manual is intended to provide you with the information needed to install, start up, clean, and maintain this ice system.

This is a modular ice system that fits a variety of Scotsman ice storage bins.

Note this symbol when it appears.



Table of Contents

FOR THE INSTALLER	Page 2
SAMPLE BIN AND MACHINE COMBINATIONS	Page 3
FOR THE INSTALLER	Page 4
FOR THE INSTALLER: Location	Page 5
FOR THE PLUMBER	Page 6
FOR THE ELECTRICIAN	Page 7
FOR THE INSTALLER	Page 8
INITIAL START UP	Page 9
CLEANING & SANITIZING	Page 10
SENSOR MAINTENANCE	Page 11
AIR COOLED MAINTENANCE	Page 12
BEARING MAINTENANCE	Page 13
AUGER MAINTENANCE	Page 14
REMOVAL AND REPLACEMENT: Bin Controls	Page 15
What to Do Before Calling for Service	Page 16

What to Do Before Calling for Service

If the machine is off, not making ice:

1. Check the water supply to the ice machine. The machine is designed to shut off if there is no water to it. Check the filters if there are any.
2. Check the power supply to the machine. Reset the breaker if it is tripped.
3. If both water and power have been checked and are available, try switching the power Off and then On. After 2 minutes the machine should restart.

If this procedure restarts the machine, service should be called the next time the machine stops.

NME454, 654 & FME504, 804 FOR THE INSTALLER

These machines fit the following Scotsman products, check sales literature for other possible combinations:

- SB480 and extensions (with bin top KBT18)
- B842 using bin top KBT28
- B948 using bin top KBT24

NME Dispenser Applications

The NME models can be placed on and used with certain ice and ice-beverage dispensers. Kits are required for proper operation, see the following list:

- ID150, use adapter KBT42 and KNUGDIV
- ID200 or ID250, use adapter KBT46 and KDIL-N-ID2
- Cornelius ED/DF200 beverage dispensers, use KBT46 and KDIL-N-200
- Cornelius ED/DF250 beverage dispensers, use KBT46 and KDIL-N-250
- Lancer nugget ice & beverage dispenser, use KDIL-N-L and Lancer kit #82-3491.

Installation Limitations:

This ice system is designed to be installed indoors, in a controlled environment:

	Min.	Max.
Air Temperature	50°F	100°F
Water Temperature	40°F	100°F
Water Pressure	20 PSI	80 PSI
Voltage (for 115v model)	104	126

(Compared to the nameplate)

Operating the machine outside of the limitations is misuse and can void the warranty.

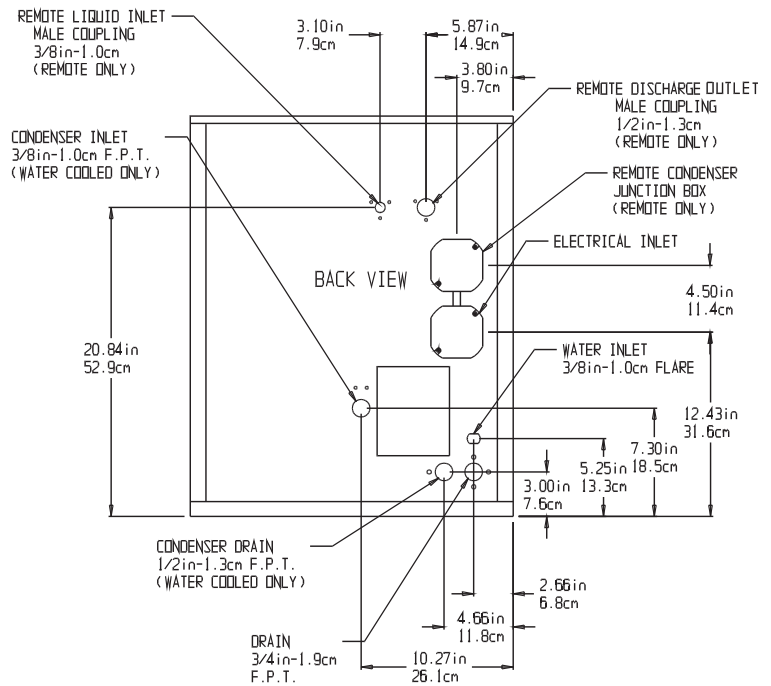

SPECIFICATIONS: ICE MACHINE

Model Number	Model Series	Dimensions	Basic Electrical	Ice Type	Condenser Type	Minimum Circuit Ampacity	Max. Fuse Size	Refrigerant Charge: R-404A
FME504AS-1	A	27" x 21" x 24"	115/60/1	Flake	Air	15.75	20	22 ounces
FME504WS-1	A	same	same	Flake	Water	14.35	20	18 ounces
FME804AS-1	B	same	same	Flake	Air	19.5	30	24 ounces
FME804WS-1	B	same	same	Flake	Water	18.3	30	19 ounces
FME804AS-32	B	same	208-230/60/1	Flake	Air	10.2	15	24 ounces
FME804WS-32	B	same	same	Flake	Water	10.2	15	19 ounces
NME454AS-1	A	same	115/60/1	Nugget	Air	15.75	20	22 ounces
NME454WS-1	A	same	same	Nugget	Water	14.35	20	18 ounces
NME654AS-1	B	same	same	Nugget	Air	19.5	30	24 ounces
NME654WS-1	B	same	same	Nugget	Water	18.3	30	19 ounces

Note: Minimum Circuit Ampacity is used to determine wire size and type per national electric code.

NME454, 654 & FME504, 804

SAMPLE BIN AND MACHINE COMBINATIONS

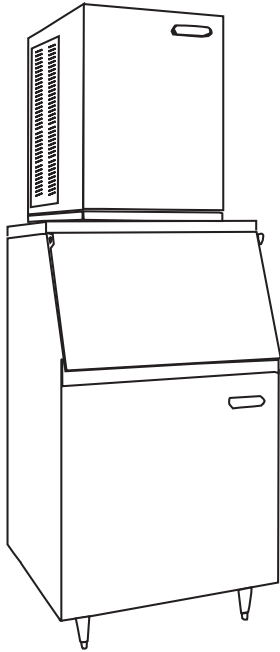

FME804 ON BH550*

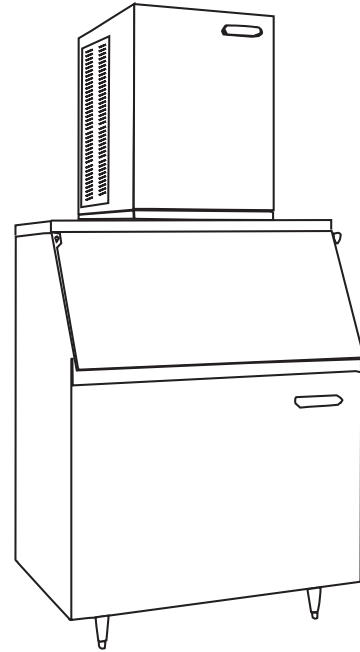

NME654 ON BH801*

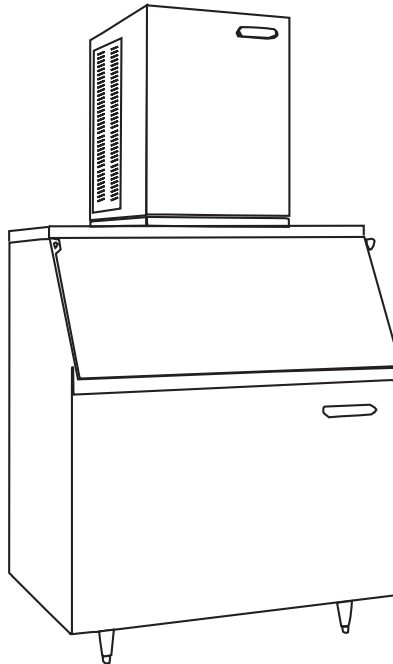

FME804 ON BH900*

The Nameplate is located on the back of the machine.

A Serial Number Plate is located inside the cabinet, behind the front panel.

***Bin Top Kit Required**

NME454, 654 & FME504, 804 FOR THE INSTALLER

Location:

Install the machine be installed in a location where it has enough space around it to be accessible for service. A minimum of 6" must be allowed at the back and sides for air circulation on air cooled models. Try to avoid hot, dirty and crowded locations. Be sure that the location for the machine is within the environmental limitations.

Storage Bin:

Tip the storage bin on its back, using parts of the carton to protect the exterior finish. Install the legs into the threaded holes in the bottom of the bin. Turn the leg levelers all the way in preparation for leveling later. Return the bin to the upright position, remove paper covering the bin gasket.

Note: Do not push bin into position, but lift it there. Pushing a bin, especially one with ice in it, can cause damage to the legs and the leg mounts.

Install the appropriate bin top on the bin, according to the instructions for the bin top.

Ice Machine:

The machine is heavy, so the use of a mechanical lift is recommended for lifting the machine high enough to install on top of the bin. After the unit is placed on the bin, line it up so it is even with the back side. Secure the machine to the bin with the hardware provided with the machine.

Remove the front panel and remove any shipping blocks.

Note: When placing 2 of these machines on a BH801 without the bin top, removal of the 2 service panels facing each other will make future service easier:

1. Remove the 2 top panel screws that will face each other.
2. Remove the 2 service panels that will face each other.
3. Add a strip of gasket, such as Scotsman part number 19-0503-04, to the 2 base edges that will face each other and around service panel space on the 2 panels that will face each other.

When the 2 machines are placed on the bin, the gaskets will seal the bin top area and the space between the machines.

Water Limitations:

An ice machine is a food manufacturing plant: it takes a raw material, water, and transforms it into a food product, ice. The purity of the water is very important in obtaining pure ice and in maximizing product life. This section is not intended as a complete resource for water related questions, but it does offer these general recommendations:

1. Check with a water treatment specialist for a water test, and recommendations regarding filters and treatment.
2. In most cases, the water used to make ice should be filtered or treated, depending upon the water. *There is no one type of water filter that is effective in all situations.* That is why a water test is important.

RO Water Limitation: Water conductivity must be no less than 35 microSiemens/cm.

Note:

Scotsman Ice Systems are designed and manufactured with the highest regard for safety and performance. They meet or exceed the standards of UL, NSF, and CUL.

Scotsman assumes no liability or responsibility of any kind for products manufactured by Scotsman that have been altered in any way, including the use of any part and/or other components not specifically approved by Scotsman.

Scotsman reserves the right to make design changes and/or improvements at any time. Specifications and design are subject to change without notice.

NME454, 654 & FME504, 804

FOR THE INSTALLER: Location

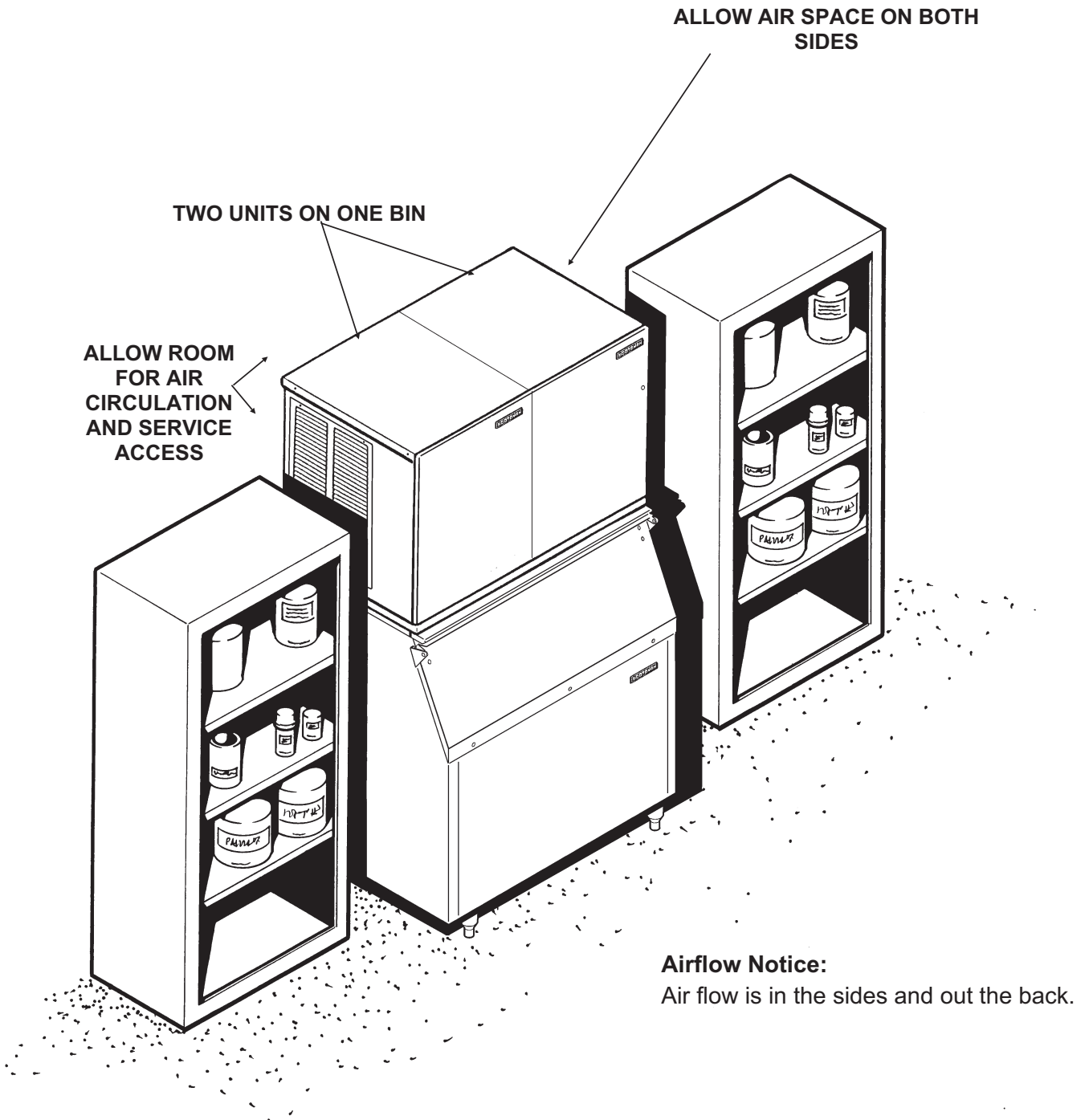

NME454, 654 & FME504, 804 FOR THE PLUMBER

CONFORM TO ALL APPLICABLE CODES

Water Inlet

Air Cooled Models: Use $\frac{3}{8}$ " O.D. copper tubing to connect cold potable water to the $\frac{3}{8}$ " male flare fitting at the back of the cabinet. Install a hand valve near the machine to control the water supply.

Water Treatment: In most areas, a water filter of some type will be useful. In areas where the water is highly concentrated with minerals the water should be tested by a water treatment specialist, and the recommendations of the specialist regarding filtration and/or treatment should be followed.

Water Cooled Models: Connect a separate $\frac{3}{8}$ " O.D. copper line, with a separate hand valve, to the $\frac{3}{8}$ " FPT condenser inlet at the back of the cabinet. The water pressure to all lines must always be above 20 PSIG, and below 80 PSIG.

Drains

Air Cooled Models: Connect a drain tube to the $\frac{3}{4}$ " FPT drain at the back of the cabinet, the drain line is of the gravity type, and $\frac{1}{4}$ inch per foot fall is an acceptable pitch for the drain tubing. There should be a vent at the highest point of the drain line, and the ideal drain receptacle would be a trapped and vented floor drain.

Use only $\frac{3}{4}$ " rigid tubing.

Water Cooled Models: In addition to the above mentioned drain, a separate condenser drain must be installed. Connect it to the $\frac{1}{2}$ " condenser drain connection at the back of the cabinet.

Storage Bin: Install a separate gravity type drain, similar to the air cooled drain. Insulation of this drain line is recommended.

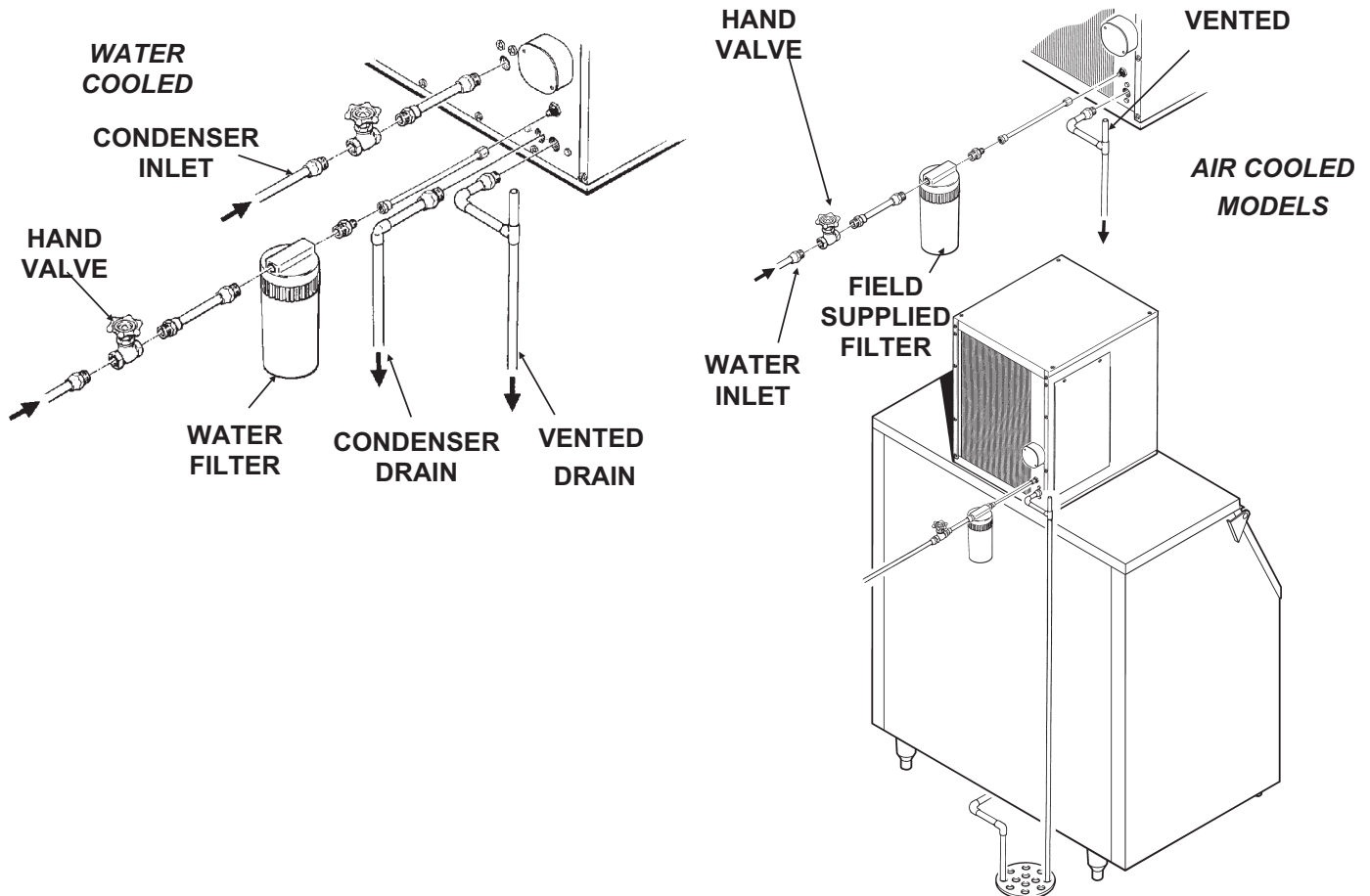

FOR THE ELECTRICIAN

CONFORM TO ALL APPLICABLE CODES

Connect the electrical power to the machine to the wires in the junction box at the rear of the machine. Check the nameplate (located on the back panel) for the voltage requirements, and for the minimum circuit ampacity. The machine requires a solid chassis to earth ground wire.

The ice machine should be connected to its own electrical circuit so it would be individually fused. Voltage variation must remain within design limitations, even under starting conditions.

All external wiring must conform to national, state, and local electrical codes. The use of a licensed electrician is required to perform the electrical installation.

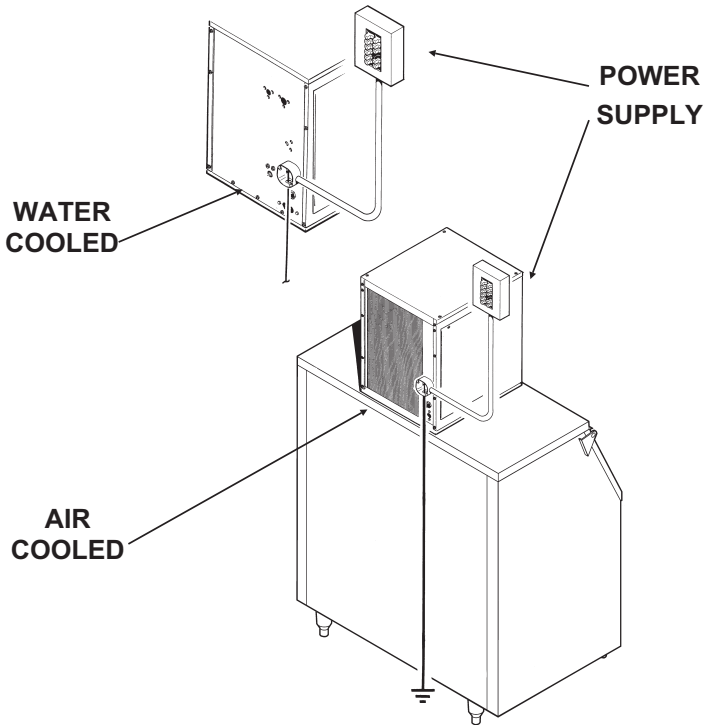

FOR THE INSTALLER

Final Check List

1. Is the ice system installed indoors in a location where the air and water temperatures are controlled, and where they do not exceed the design limitations?
2. Is there an electrical service disconnect within sight of the installed machine? Has the voltage been checked, and compared to nameplate requirements?
3. Have all the plumbing connections been made and checked for leaks?
4. Has the machine and bin been leveled?
5. Is there a minimum of 6" clearance at the back of the machine for proper service access and air circulation?
6. Is the water pressure a minimum of 20 PSIG?
7. Has the machine been secured to the bin?
8. Is there clearance over the top of the machine for service access?
9. Is there a water shut off valve installed near the machine?
10. Have all of the shipping blocks been removed?

NME454, 654 & FME504, 804

INITIAL START UP

Pre-Start Inspection

1. Remove the front and side service panels. are rubbing each other. Check that the fan blade turns freely (air cooled).
2. Check that any shipping blocks have been removed.
3. Inspect the interior of the machine for loose screws or wires. Check that no refrigerant lines
4. Check that the unit is installed correctly according to the final check list (page 8).

Start Up

1. Go through the prestart inspection.
2. Open the hand valve, observe that water enters the water reservoir, fills the tube from the reservoir to the evaporator, and then shuts off. Check for leaks.
3. Switch the master switch on. There will be a short delay before the gearmotor and compressor will start.
4. On air cooled models, the condenser will begin to discharge warm air, on water cooled models, the water regulating valve will open, and warm water will be discharged into the drain.
5. The unit should soon be making ice, if desired, the low side pressure can be checked: it should be 34 PSIG + or - 4 PSIG.
The suction line temperature at the compressor is normally very cold, nearly to the point of frost up to the compressor body, but not on it.
6. **THERE ARE NO ADJUSTMENTS TO MAKE**, so replace the panels.
7. Clean and/or sanitize the storage bin interior, wipe off the exterior with a clean, damp cloth.
8. Give the owner/user the service manual, instruct him/her in the operation of the unit, and make sure they know who to call for service.
9. Fill out the manufacturer's registration and mail it to Scotsman.

Water Level: The correct water level should be checked when the machine is making ice. Check the water level in the reservoir and compare it to the horizontal line molded into the side of the reservoir. The correct level should be between $\frac{1}{8}$ " above and $\frac{1}{4}$ " below the line. If needed, bend the float arm up or down to adjust the water level.

CLEANING & SANITIZING

A Scotsman Ice System represents a sizable investment of time and money in any company's business. In order to receive the best return for that investment, it MUST receive periodic maintenance.

It is the USER'S RESPONSIBILITY to see that the unit is properly maintained. It is always preferable, and less costly in the long run, to avoid possible down time by keeping it clean; adjusting it as needed; and by replacing worn parts before they can cause failure. The following is a list of recommended maintenance that will help keep the machine running with a minimum of problems.

Maintenance and Cleaning should be scheduled at a **minimum of twice per year.**

Note: Electrical power will be ON when doing in place cleaning.

ICE MAKING SYSTEM: In place cleaning

1. Check and clean any water treatment devices, if any are installed.
2. Remove screws and the front and top panels.
3. Move the ON-OFF switch to OFF.
4. Remove all the ice from the storage bin.
5. Remove the cover to the water reservoir and block the float up.
6. Drain the water reservoir and freezer assembly using the drain tube attached to the freezer water inlet. Return the drain tube to its normal upright position and replace the end cap.
7. Prepare the cleaning solution: Mix eight ounces of Scotsman Ice Machine Cleaner with three quarts of hot water. The water should be between 90-115 degrees F.

	<p>WARNING</p> <p>Scotsman Ice Machine Cleaner contains acids. These compounds may cause burns.</p> <p>If swallowed, DO NOT induce vomiting. Give large amounts of water or milk. Call Physician immediately. In case of external contact, flush with water.</p> <p>KEEP OUT OF THE REACH OF CHILDREN.</p>
---	---

8. Slowly pour the cleaning solution into the water reservoir until it is full. Wait 15 minutes, then switch the master switch to ON.
9. As the ice maker begins to use water from the reservoir, continue to add more cleaning solution to maintain a full reservoir.

10. After all of the cleaning solution has been added to the reservoir, and the reservoir is nearly empty, switch the master switch to OFF.

11. Drain the water reservoir and freezer assembly using the drain tube attached to the freezer water inlet. Return the drain tube to its normal upright position and replace the end cap. Wash and rinse the water reservoir.

Sanitizing:

To sanitize, use an approved sanitizing solution or mix one ounce of household bleach to 2 gallons of warm (95°F.-115°F.) water. Repeat steps 8-11 using the sanitizer solution in place of the cleaning solution.

12. Remove the block from the float in the water reservoir.

13. Switch the master switch to ON

14. Continue ice making for at least 15 minutes, to flush out any cleaning solution.

DO NOT USE any ice produced from the cleaning solution.

Be sure no ice remains in the bin.

15. Remove all ice from the storage bin.

16. Add warm water to the ice storage bin and thoroughly wash and rinse all surfaces within the bin.

17. Sanitize the bin interior with an approved sanitizer using the directions for that sanitizer.

18. Replace the panels.

NME454, 654 & FME504, 804 SENSOR MAINTENANCE

1. The bin control is a device that senses light, therefore it must be kept clean so it can “see”. At least twice a year, remove the bin control sensors from the base of the ice chute, and wipe the inside clean, as illustrated.

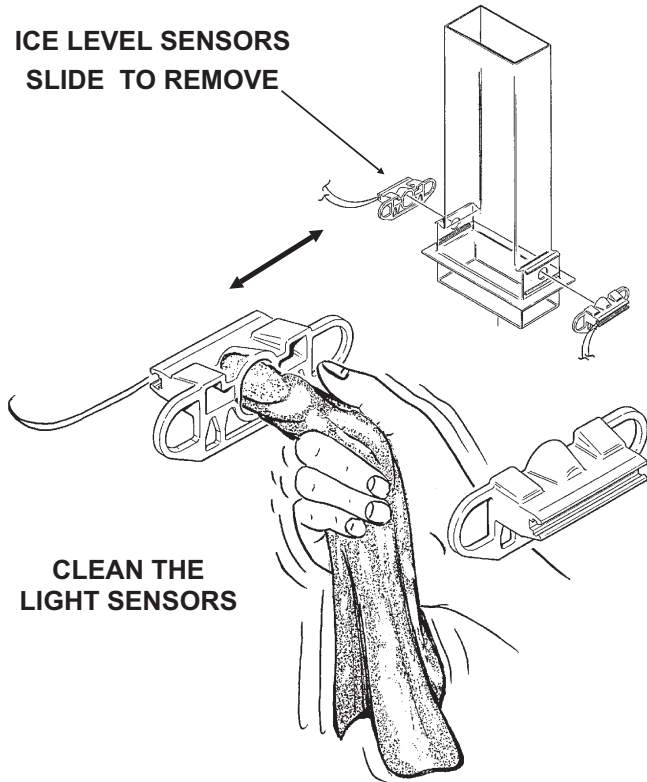

2. The ice machine senses water level by a probe located in the water reservoir. At least twice a year, the probe should be removed from the reservoir, and the tip wiped clean of mineral build-up.

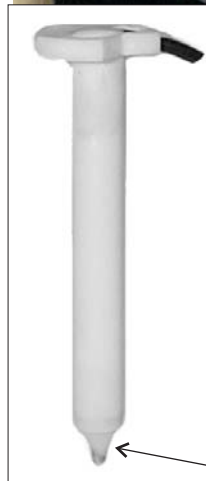
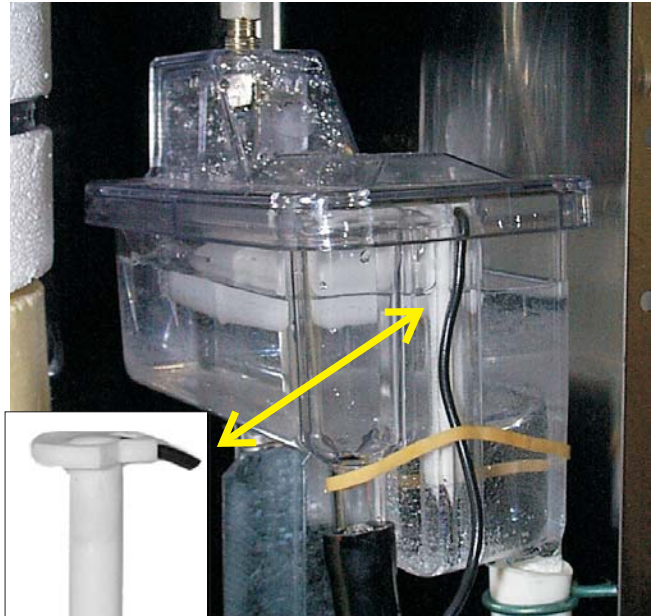

Clean the Probe's Tip with ice machine cleaner and a clean, soft cloth.

AIR COOLED MAINTENANCE

	⚠ WARNING
	Hazardous Moving Parts. Moving fan blade can cause personal injury. Disconnect electrical power before beginning.

Clean the air cooled condenser.

The air flow on this model is from front to back, so the inside of the machine will have to be available to clean the air cooled condenser. Use a vacuum cleaner or coil cleaner if needed. Do NOT use a wire brush.

- A. Disconnect electrical power, and remove the filter. The filter may be cleaned or replaced.
- B. Clean the condenser: the condenser may appear to be clean on the surface, but it can still be clogged internally. Check with a flash light from the front to see if light can be seen though the condenser fins. Reverse to reassemble.

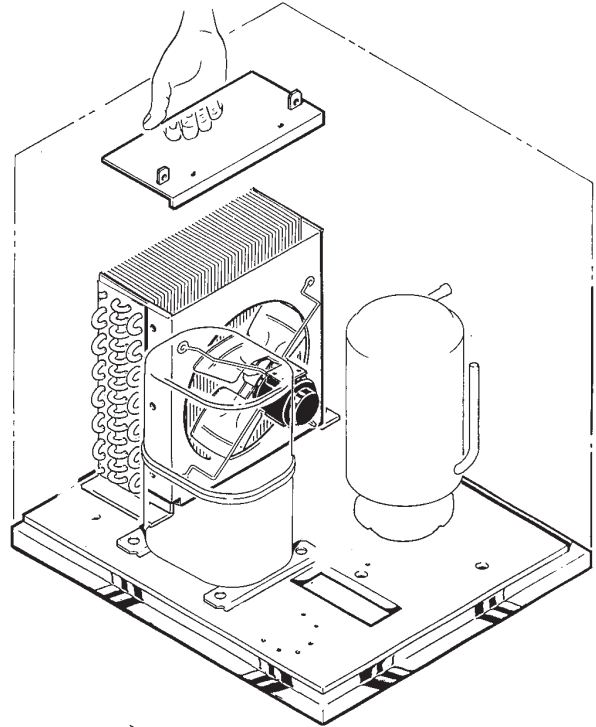

Step 2: Remove the top portion of the fan shroud.

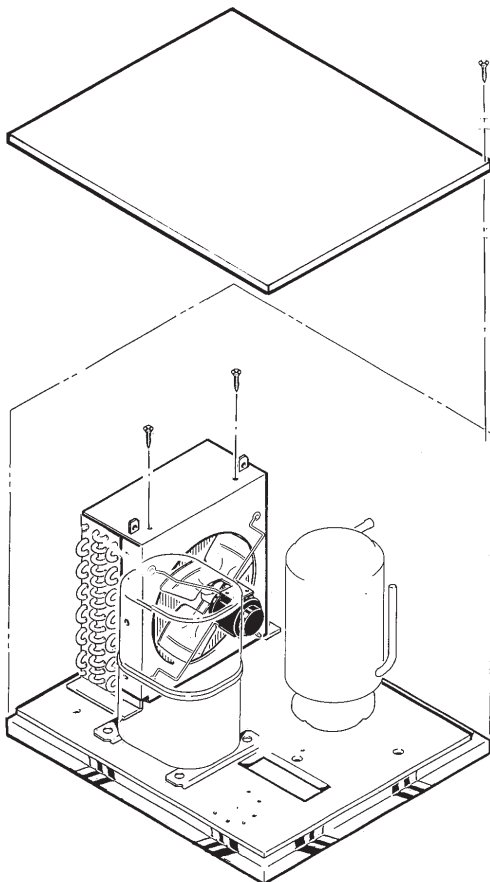

Step 1: Remove the top panel.

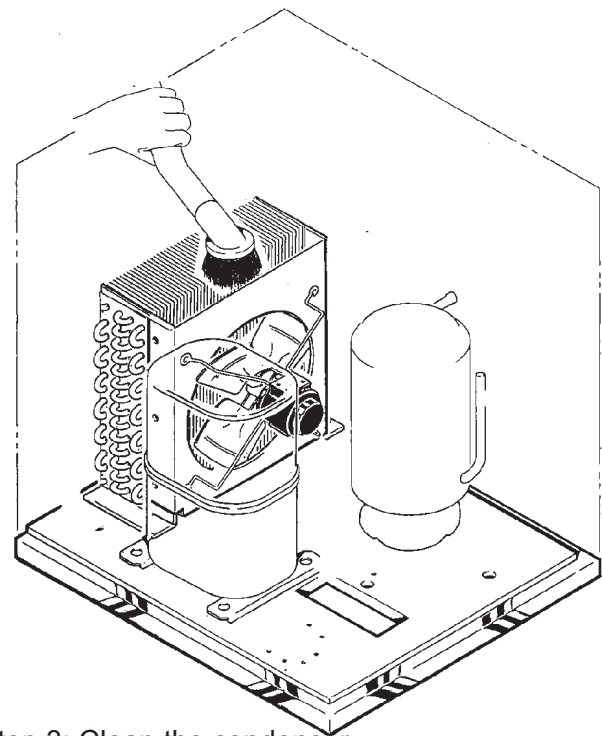

Step 3: Clean the condenser.

NME454, 654 & FME504, 804 BEARING MAINTENANCE

The bearing in the breaker should also be checked at least **two times per year**.

A. Check the bearing by:

- removing the ice chute cover



- unscrewing the ice sweep



- removing the water shed & unscrewing the breaker cover (left hand threads).

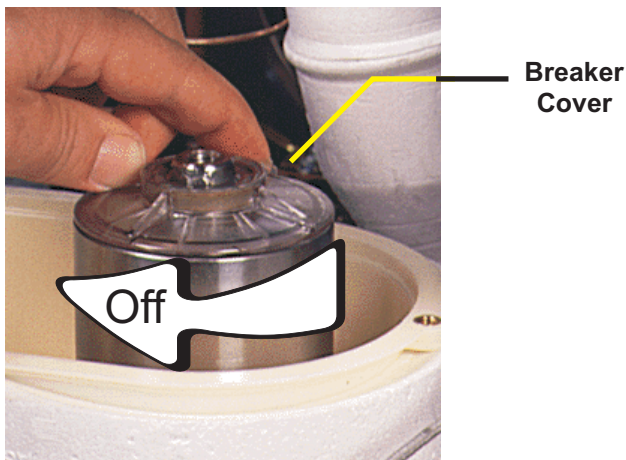

- unscrewing the auger stud

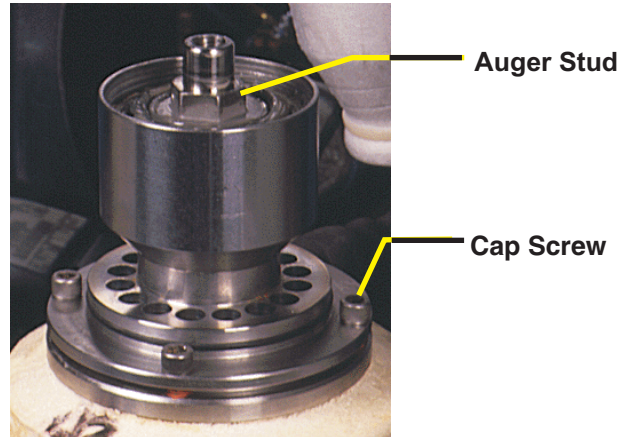

Inspect the bearing. There should be plenty of grease in sight. If grease is needed the bearing and breaker should be removed to check the action of the bearing. It should rotate smoothly.

To remove the breaker remove the lower ice chute then take out all four allen head cap screws and pull the breaker off the auger and evaporator.

If the bearing only needs grease, inject grease into the bearing using Scotsman grease needle pn 02-3559-01 and Scotsman bearing grease cartridge, pn A36808-001. Be sure to inject grease evenly and thoroughly.

See Removal and Replacement section to replace bearing or seals.

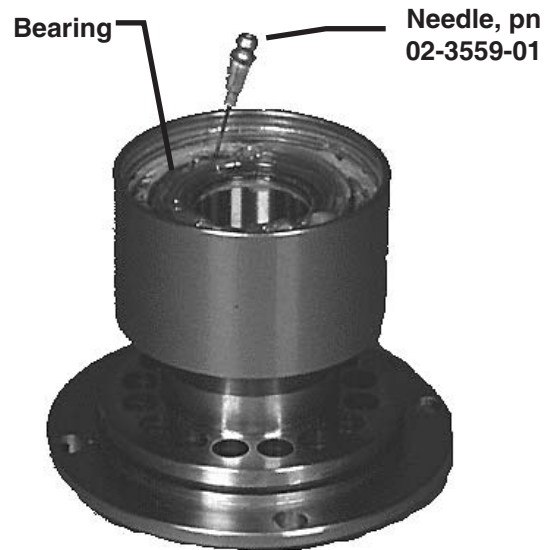

Reverse to reassemble.

AUGER MAINTENANCE

In some areas, the water supply to the ice maker will contain a high concentration of minerals, and that will result in an evaporator and auger becoming coated with these minerals, requiring a more frequent removal than twice per year. If in doubt about the condition of the evaporator and auger, the auger can be removed so the parts can be inspected.

Note: Water filters can filter out suspended solids, but not dissolved solids. "Soft" water may not be the complete answer. Check with a water treatment specialist regarding water treatment.

For more information on removal of these parts, see REMOVAL AND REPLACEMENT.

1. To remove the auger, remove the front and top panels.
2. Push bail clamp back from the top of the chute cover.
3. Unscrew and remove ice sweep.

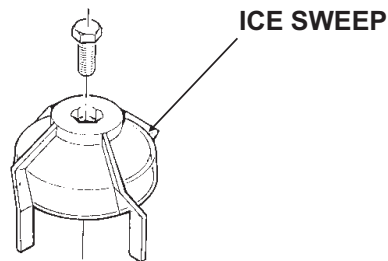

FME Components Shown, NME similar.

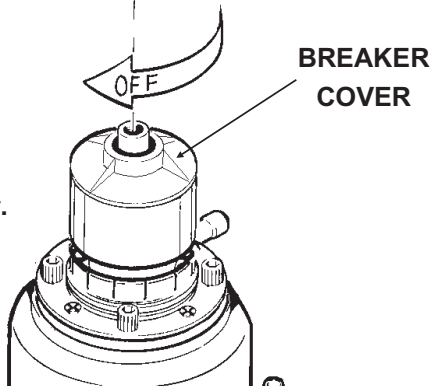

4. Remove 4 allen screws holding breaker to evaporator.

5. Pull up to remove auger.

After the auger has been removed, allow the auger to dry: if the auger is not bright and shiny, it must be cleaned.

Clean the auger and evaporator as required. DO NOT HONE THE EVAPORATOR.

FME Components Shown, NME similar.

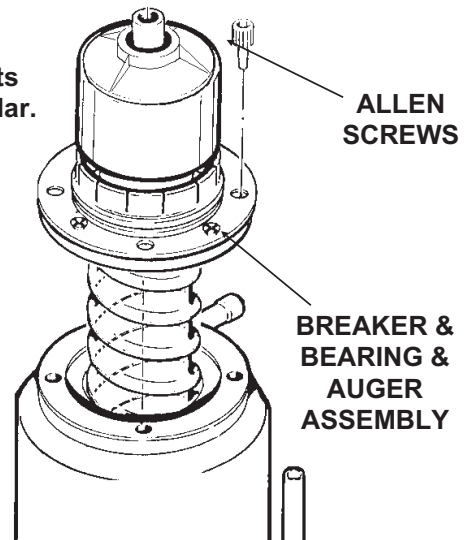

7. Replace the water seal.

8. Reverse to reassemble.

NME454, 654 & FME504, 804

REMOVAL AND REPLACEMENT: Bin Controls

BIN CONTROLS (Ice Level Sensors)

1. Disconnect electrical power.
2. Remove front panel.
3. Remove control box cover.
4. Locate ice chute, at the base of the chute, in front of and behind it are two plastic bin control mounts.
5. Slide each bin control to the left, and in the control box, disconnect the electrical leads connecting the bin control to the circuit board.
6. Reverse to reassemble, be certain that the bin controls are aligned so that the ice level sensors are visible (centered) through the holes in the ice chute.

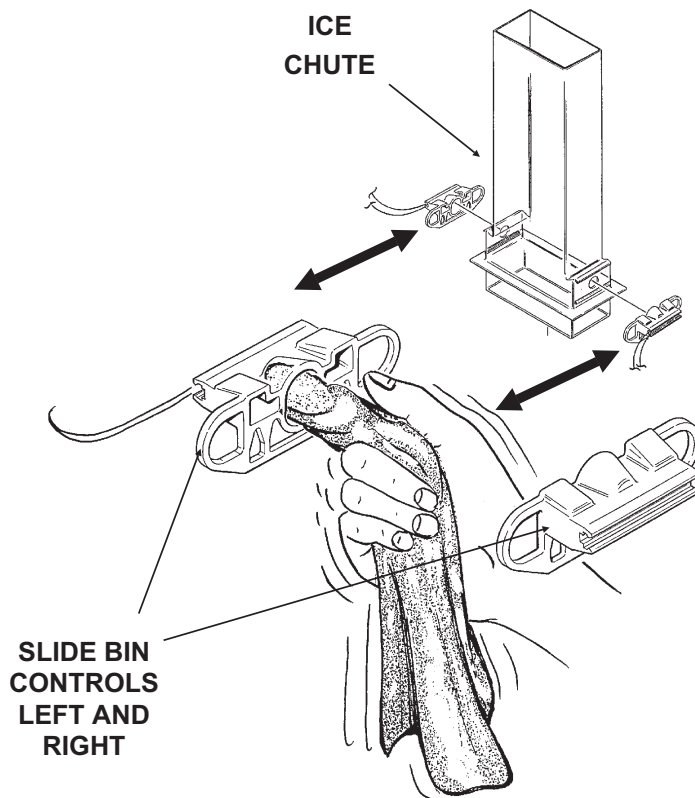

RESERVOIR

1. Shut off water supply.
 2. Remove front panel.
 3. Remove reservoir cover.
 4. Disconnect water inlet tube from reservoir inlet fitting.
 5. To remove float valve, push in on "Locking Tab" as shown and pull valve up.
- Note: The plunger/seat is available as a separate part.
6. To remove reservoir, pull up and remove water sensor.
 7. Disconnect water outlet tubes.
 8. Remove the two screws holding reservoir to bracket.
 9. Remove reservoir from ice machine.
 10. Reverse steps 1-9 to reassemble.

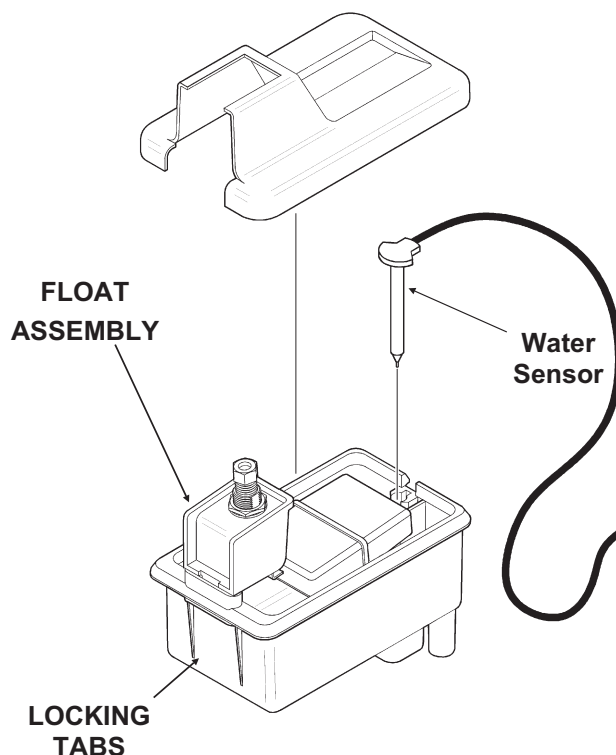

Scotsman[®]

SCOTSMAN ICE SYSTEMS
775 Corporate Woods Parkway, Vernon Hills, IL 60061
800-533-6006
www.scotsman-ice.com

17-3154-01